



Juncor 



iwis

antriebssysteme
wir bewegen die welt

**Correntes de precisão para
Sistemas de transmissão e
transporte**

Guarde este catálogo no seu smartphone ou tablet



Product range



**Precision chain systems
for drive and conveyor purposes**



Welcome **iwis**

© Copyright iwis antriebssysteme GmbH & Co. KG, München, Germany 2009

The contents of this catalogue are the copyright of the publisher and may not be reproduced (even extracts) unless permission is granted. Every care has been taken to ensure the accuracy of the information contained in this catalogue but no liability can be accepted for any errors or omissions.

Printed: EB EN 04/2009 3.000

at antriebssysteme!

The direct route
to your order!

You can reach our Customer
Service Team on weekdays from
8 am to 6 pm non-stop.

Phone:
+49 89 76909-1600

Or send your order by fax.
For this purpose please use our enquiry
form at the end of this catalogue.

Fax:
+49 89 76909-1122

Our Customer Service Team
will attend to your enquiries
and orders immediately.

sales-muenchen
@iwis.com

For further information regarding
our products please visit also
our company website:

www.iwis.com

Contents **iwis** product

Our Company

- 1 Welcome
- 2 Contents
- 4 **iwis antriebssysteme**
- 6 **iwis® A brand which stands for highest precision**
- 8 **Highlights, applications and customer benefits**
- 10 **Our service offers**

Product range

- 12 **iwis® Roller chains**
 - 14 acc. to DIN 8187-1
 - 16 acc. to DIN 8188-1
 - 16 Double-pitch type (to DIN 8181)
- 18 **iwis® Conveyor chains**
 - 20 with straight attachment plates
 - 22 with bent attachment plates
 - 27 with extended bearing pins
 - 28 multiple strand connecting links
 - 29 with U-shaped attachments
- 30 **iwis® MEGAlife maintenance free chains**
 - 34 MEGAlife I roller chains
 - 35 Conveyor chains with straight attachment plates
 - 36 Conveyor chains with bent attachment plates
 - 37 Conveyor chains with extended pins
 - 38 MEGAlife II roller chains

range

Product range

- 40 **DWIS**® CR chains – corrosion resistant chains
- 44 **DWIS**® Power and free conveyor chains
 - 46 New power and free conveyor chains
 - 48 Side bow power and free conveyor chains
 - 49 Classic power and free conveyor chains
 - 50 MEGAlife SFK & SFS
 - 52 Accessories
- 56 **DWIS**® Special chains
 - 58 Plate chains
 - 59 Transfer chains
 - 61 Grip chains
 - 62 Pallet transporting chains
 - 63 Side bow chains
 - 64 Anti back bend chains
 - 64 Hollow pin chains
 - 65 Tube transport chains
 - 66 Can transport chains
 - 67 Leaf chains

Drive line products

- 68 **DWIS**® Sprockets and plate wheels
- 72 **DWIS**® Tools
- 84 **DWIS**® Automatic Tensioners

Chain guide

- 98 Perfect lubrication
- 101 Efficient chain maintenance
- 102 Chain guideline
- 104 Questionnaire for chain drives

iwis

Joh. Winklhofer Beteiligungs GmbH & Co. KG

Company Headquarters, Parent of the independent subsidiary companies,
Management Organisation of the Internationally operating companies

iwis motorsysteme GmbH & Co. KG

Subsidiary for the automotive sector, for example chain drives and mass balance drives as well as oil pump drives and gear box chains



Munich (D)
Landsberg (D)
Tipton (UK)
Shanghai (CN)
São Paulo (BRA)
Seoul (KR)

iwis antriebssysteme GmbH & Co. KG

Subsidiary for the industrial sector, high precision chains and drive systems for a wide range of applications



Munich (D)
Strakonice (CZ)
Mezrieu (F)
Tipton (UK)
Othmarsingen (CH)
Indianapolis (USA)
Langley (CA)
São Paulo (BR)
Shanghai (CN)

iwis antriebssysteme GmbH

A distribution and service company within the chain drive industry



ecoplus

Wilnsdorf (D)
Mezrieu (F)
Tipton (UK)
Indianapolis (USA)
Othmarsingen (CH)
Langley (CA)
São Paulo (BR)
Shanghai (CN)

iwis agrisystems (Div.)

Competence centre for the iwis agricultural chain program for combines and maize harvesting



Sontra (D)
Mezrieu (F)
Tipton (UK)
Indianapolis (USA)
Othmarsingen (CH)
Langley (CA)
São Paulo (BR)
Shanghai (CN)



90 years **iwis**

A company which has developed over 90 years has a story. The entrepreneurial family Winklhofer has been managing the fate of the company iwis since decades and has developed it into a group of companies which committed itself to tradition, precision and innovation. This group of companies produces high precision roller chains and systems for the automotive industry, the machine and plant manufacture, the packaging, printing and food industries, the agriculture and for industrial applications in the field of conveyor technology. More than 1000 employees at the production sites of Munich, Landsberg am Lech, Wilnsdorf, Sontra and Strakonice (CZ) have committed themselves to a quality standard on the highest level.

Our consequent customer orientation in all areas lead to a close cooperation with our customers and suppliers as well as to joint technical developments – as our goal is to always offer our customers a solution at the highest quality and sustainability level. Research and development play a major role in our company's philosophy: The detection of new trends and the development of new materials and production technologies require an innovative power and motivation of which we are proud of and which explain our top position in the market. Thus iwis antriebssysteme GmbH & Co. KG is a worldwide driving force in the general machine manufacture and delivers precision chain systems which move all around the world.



A brand which stands for highest precision.



Technical perfection of highest quality for a maximum customer benefit – that is our high standard. 100% exact replication of more than 30 million spare parts every single day – a quality benchmark which a single expression stands for at iwis: Highest precision. We are proud of that fact and numerous certifications and awards in the quality sector shows us that we follow the right path!





Precision for your success



Technical perfection

- Use of high quality quenched, tempered and case-hardened steels
- High precision fabrication via SPC (statistical process control)
- Quality assurance complying with ISO 9001
- Optimisation of quality features via special heat treatment
- Constant monitoring of the chains for dimensional accuracy and articulation
- Surface coatings
- Special lubricants
- Special materials (i.e. corrosion-proof)

Highest possible quality

- Above average length of life
- Excellent wear resistance
- Restricted length tolerances down to 1/6 of the DIN tolerance
- Significantly higher fracture-resistance than the norm
- High fatigue strength
- All iwis chains are pretensioned
- Extremely efficient initial lubrication

Benefits to the user

- Longer maintenance intervals
- Maintenance-friendly, easy and quick to dismantle
- Fewer down times
- Benefits of parallel and synchronous running
- Extremely precise positioning
- Extremely quiet running
- Safety reserves at load peaks
- Reduced stretching during running-in

Application fields

- Printing presses
- Paper manufacturing and processing machines
- Copiers
- Ceramics and glass industry
- Packaging machines
- Medical technology
- Textile machines
- Machine tools
- Machines for processing plastics
- General engineering and systems construction
- Woodworking machinery
- Agricultural machinery
- Office equipment
- Building materials industry
- Construction machinery
- Conveyor technology
- Chemical engineering and process technology
- Tube and can industry

Your perfect engineering partner



A scientific based company

iwis has the largest chain Research and Development department in Europe, having more than 60 development engineers solely engaged for the engineering of chain drive systems. Besides basic development and designing innovative customer solutions, the main focus of iwis Research and Development division ranges from calculations, design and testing to wear elongation and fatigue strength analysis.

- Special knowledge of noise emission analysis and vibration engineering
- Our laboratory has the capabilities to carry out many different testing possibilities including microscopy, metallography, evaluation of mechanical properties, chemical composition and qualified analysis of data
- Dynamic simulation/analysis of chain drive systems with regard to chain load, torsional vibrations and friction losses
- FEM analysis of individual chain drive parts – static and dynamic stress and strength investigations
- Evaluation of iwis and customer readings at test facilities for verification of simulation models
- Identification of thermal characteristics of chain drives while testing in the climate-testing laboratory.



Evaluation of chain breaking strength and elongation up to 1000kN



More than 15 pulser are available for testing dynamic fatigue strength according to different testing methods



Testing of chain wear elongation behaviour on more than 20 test rigs



Each customer problem is a challenge for us. Either you need a special conveyor chain or perhaps an own chain configuration, integrating chain wheels and guides in existing modules:

Troubleshooting

As a system manufacturer our specialists offer you individual solutions, which go far beyond the chain focus on the entire application and answer your problem as a whole. Our research and development department stands for creativity and innovation, as well as for a cooperation hand in hand with our customers. Do not hesitate to contact us in case you have a special problem.



Extreme flexibility

Offering solutions for individual customer problems as well, is our speciality and part of our company's philosophy. By conducting feasibility studies hand in hand with our customers, producing components and executing deformation and stress tests we are able to adjust existing products to individual customer requirements or to develop new chain drives. By means of vibration and stress tests of the components the physical properties of the chain are examined. We try the prototypes on test stands which expose the chain drives to extreme conditions and pressure to ensure its durability and life time. Our customers can and have to be sure that they receive a high quality product – that is our requirement.

iwis - your strong partner

The iwis group goes global. By supporting own affiliated companies in Great Britain and Switzerland as well as sites in Brazil, China, France and the USA the iwis group operates internationally. iwis products are being sold by distribution partners in more than 30 countries on all continents.

outside Germany as well

iwis has realised the chances of the globalisation at an early stage and has established a distribution structure by a targeted positioning which guarantees a worldwide supply. Thus we do not only open up new markets but our customers can appeal to a familiar and reliable local partner with regard to their business activities abroad.

You are important to us and therefore we are happy to support you in word and deed. Let our competent specialists of our technical service team and our committed external force advise you. We would like to do calculations and chain designs for you and give you advice as far as your choice of the right chain for your applications is concerned. You can reach our Customer Service Team at any time on weekdays from 8 am to 6 pm. And by the way: We are happy to service you during the operating time of the chain as a reliable partner in all matters that arise right around the iwis chain.

Our service for our customers



JWTS[®] Roller chains

are characterised by an above-average service life due to excellent wear resistance, high consistency, matchless precision and a considerably higher breaking strength and fatigue strength than required by DIN/ISO standard. All iwis chains are pre-stretched and are provided with a highly efficient initial lubrication.

iwis SL series chains (Super Longlife) have pins with an extremely hard surface. This special design shows outstanding characteristics: Highest wear resistance, a prolonged service life, high breaking and fatigue strength, low susceptibility to deficient operational lubrication, corrosion and frictional corrosion in the chain links.





iwis® Roller chains

according to DIN 8187-1, ISO 606: 2004 and iwis standard

DIN/ISO no.	Ref. no. iwis	Pitch p (")	Pitch p (mm)	Breaking load F_B				Chain components and connecting links Nos.	Inner link			Outer link			
				iwis (N) ave.	Norm (N) min.	Bearing area F (cm ²)	Weight per m q (kg/m)		b_1 (mm) min.	b_2 (mm) max.	g (mm) max.	a_1 (mm) max. ²⁾	a (mm) max. ²⁾	Roller d (mm) max.	Pin d_1 (mm) max.
Simplex															
04	G 42	6 x 2,8 mm	6,00	3.200	3.000	0,07	0,12	2, 3, 7, 8	2,80	4,10	5,00	6,70	7,60	4,00	1,85
05 B-1	G 52	8 mm x 1/8"	8,00	6.000	5.000	0,11	0,18	2, 3, 7, 8	3,16	4,85	7,10	8,10	9,20	5,00	2,31
-	G 53 HZ ^{1) 3)}	8 mm x 3/16"	8,00	8.500	-	0,25	0,34	2, 8	4,76	7,90	7,60	11,70	-	5,00	3,15
-	G 62 1/2 ¹⁾	3/8 x 5/32"	9,525	11.000	-	0,22	0,34	2, 3, 7, 8	3,94	6,63	8,20	11,00	12,20	6,35	3,31
06 B-1	G 67 ¹⁾	3/8 x 7/32"	9,525	10.500	9.000	0,28	0,41	2, 3, 6, 7, 8	5,72	8,53	8,20	12,90	14,10	6,35	3,31
-	P 83 V	1/2 x 3/16"	12,70	15.500	-	0,29	0,44	2, 3, 6, 7, 8	4,88	7,97	10,20	13,20	14,10	7,75	3,68
-	S 84 V	1/2 x 1/4"	12,70	18.000	-	0,38	0,58	2, 3, 6, 7, 8	6,40	9,65	12,00	15,00	16,00	7,75	3,97
08 B-1	L 85 SL*	1/2 x 5/16"	12,70	22.000	18.000	0,50	0,70	2, 3, 6, 7, 8	7,75	11,30	11,80	16,90	18,50	8,51	4,45
10 B-1	M 106 SL*	5/8 x 3/8"	15,875	27.000	22.400	0,67	0,95	2, 3, 6, 7, 8	9,65	13,28	14,40	19,50	20,90	10,16	5,08
12 B-1	M 127 SL*	3/4 x 7/16"	19,05	34.000	29.000	0,89	1,25	2, 3, 4, 6, 7, 8	11,75	15,62	16,40	22,70	23,60	12,07	5,72
16 B-1	M 1611*	1" x 17mm	25,40	75.000	60.000	2,10	2,70	2, 3, 6, 7, 8	17,02	25,45	21,10	36,10	36,90	15,88	8,28
20 B-1	M 2012	1 1/4 x 3/4"	31,75	120.000	95.000	2,92	3,72	2, 4, 6, 8	19,56	29,01	25,40	40,50	46,30	19,05	10,19
24 B-1	M 2416	1 1/2 x 1"	38,10	211.000	160.000	5,50	7,05	2, 4, 6, 8	25,40	37,92	33,50	53,10	60,00	25,40	14,63
28 B-1	M 2819	1 3/4 x 31mm	44,45	250.000	200.000	7,35	8,96	2, 4, 6, 8	30,95	46,58	37,00	63,60	69,90	27,94	15,90
32 B-1	M 3219	2" x 31mm	50,80	315.000	250.000	8,05	10,00	2, 4, 6, 8	30,95	45,57	42,30	65,10	70,10	29,21	17,81

¹⁾ Also available with straight side plates ²⁾ Varying dimensions for cranked links ³⁾ Bush chain

* easy break – chains with shouldered pins

The suffix SL indicates chains with particularly wear-resistant pins.

It should be noted that if cranked links are fitted, the breaking strength of the chain may be reduced by approximately 20%.

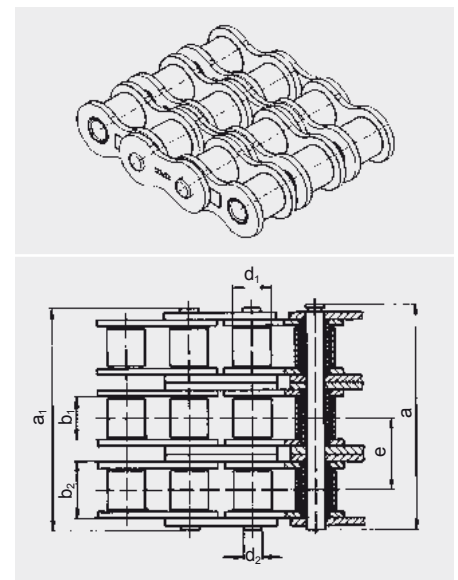
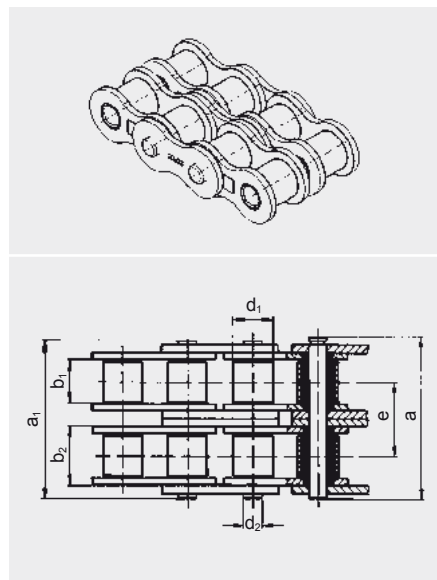
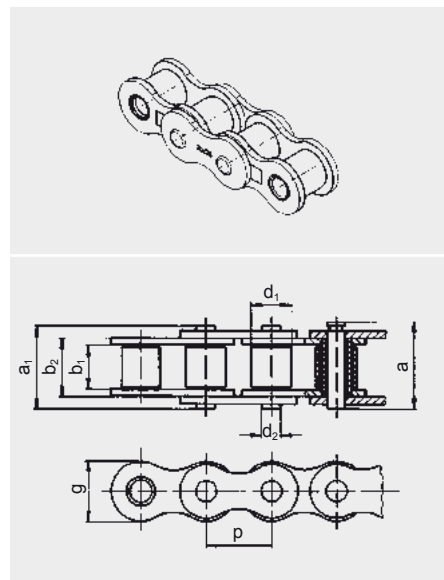

iwis® Roller chains

according to DIN 8187-1, ISO 606: 2004 and iwis standard

DIN ISO no.	Ref. no. iwis	Pitch p (")	Pitch p (mm)	Breaking load F _B			Weight per m q (kg/m)	Chain components and connecting links	Inner link			Outer link			Pin d ₂ (mm) max.	Transverse pitch e (mm)
				iwis (N) ave.	Norm (N) min.	Bearing area F (cm ²)			b ₁ (mm) min.	b ₂ (mm) max.	g (mm) max.	a ₁ (mm) max. ²⁾	a (mm) max. ²⁾	Roller d (mm) max.		
Duplex																
05 B-2	D 52	8"	8,00	9.100	7.800	0,22	0,36	2, 3, 8	3,16	4,85	7,10	13,90	15,00	5,00	2,31	5,64
06 B-2	D 67 ¹⁾ *	3/8"	9,525	20.000	16.900	0,56	0,78	2, 3, 6, 7, 8	5,72	8,53	8,20	23,40	24,60	6,35	3,31	10,24
08 B-2	D 85 SL*	1/2"	12,70	40.000	32.000	1,00	1,35	2, 3, 6, 7, 8	7,75	11,30	12,20	30,80	32,40	8,51	4,45	13,92
10 B-2	D 106 SL*	5/8"	15,875	56.000	44.500	1,34	1,85	2, 3, 6, 7, 8	9,65	13,28	14,40	36,00	37,50	10,16	5,08	16,59
12 B-2	D 127*	3/4"	19,05	68.000	57.800	1,78	2,50	2, 3, 6, 7, 8	11,75	15,62	16,40	42,10	43,00	12,07	5,72	19,46
16 B-2	D 1611*	1"	25,40	150.000	106.000	4,21	5,40	2, 3, 6, 7, 8	17,02	25,45	21,10	68,00	68,80	15,88	8,28	31,88
20 B-2	D 2012	1 1/4"	31,75	210.000	170.000	5,84	7,36	2, 4, 6, 8	19,56	29,01	25,40	79,70	82,90	19,05	10,19	36,45
24 B-2	D 2416	1 1/2"	38,10	370.000	280.000	11,00	13,85	2, 4, 6, 8	25,40	37,92	33,50	101,80	106,50	25,40	14,63	48,36
28 B-2	D 2819	1 3/4"	44,45	500.000	360.000	14,70	18,80	2, 4, 6, 8	30,95	46,58	37,00	124,70	129,20	27,94	15,90	59,56
32 B-2	D 3219	2"	50,80	530.000	450.000	16,10	19,80	2, 4, 6, 8	30,95	45,57	42,30	126,00	128,30	29,21	17,81	58,55
Triplex																
08 B-3	Tr 85*	1/2"	12,70	58.000	47.500	1,50	2,00	2, 3, 7, 8	7,75	11,30	12,20	44,70	46,30	8,51	4,45	13,92
10 B-3	Tr 106*	5/8"	15,875	80.000	66.700	2,02	2,80	2, 3, 7, 8	9,65	13,28	14,40	52,50	54,00	10,16	5,08	16,59
12 B-3	Tr 127*	3/4"	19,05	100.000	86.700	2,68	3,80	2, 3, 7, 8	11,75	15,62	16,40	61,50	62,50	12,07	5,72	19,46
16 B-3	Tr 1611*	1"	25,40	220.000	160.000	6,32	8,00	2, 3, 6, 7, 8	17,02	25,45	21,10	99,20	100,70	15,88	8,28	31,88
20 B-3	Tr 2012	1 1/4"	31,75	315.000	250.000	8,76	11,00	2, 4, 6, 8	19,56	29,01	25,40	116,10	119,40	19,05	10,19	36,45
24 B-3	Tr 2416	1 1/2"	38,10	560.000	425.000	16,50	20,31	2, 4, 6, 8	25,40	37,92	33,50	150,20	155,40	25,40	14,63	48,36
28 B-3	Tr 2819	1 3/4"	44,45	750.000	530.000	22,05	28,00	2, 4, 6, 8	30,95	46,58	37,00	184,60	188,90	27,94	15,90	59,56
32 B-3	Tr 3219	2"	50,80	795.000	670.000	24,15	29,60	2, 4, 6, 8	30,95	45,57	42,30	184,50	186,50	29,21	17,81	58,55

¹⁾ Straight side plate ²⁾ Varying dimensions for cranked links

The suffix SL indicates chains with particular wear-resistant pins.

It should be noted that if cranked links are fitted, the breaking strength of the chain may be reduced by approximately 20%.

CHAIN COMPONENTS AND CONNECTING LINKS



Nr. 2 Inner links
Standard designation B

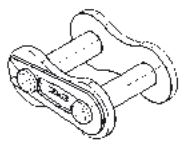

Nr. 3 Connecting link with spring clip
Standard designation E

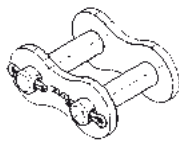

Nr. 4 Connecting link with split pin fastening
Standard designation S

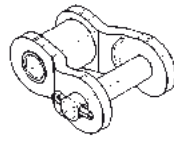

Nr. 6 Single cranked link with split pin fastening
Standard designation L

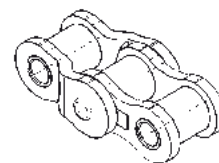

Nr. 7 Double cranked links
Standard designation C

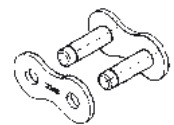

Nr. 8 Outer link
Standard designation A

iwis® Roller chains

according to DIN 8188-1, American standard, ISO 606: 2004

DIN ISO no.	Ref. no. iwis	ANSI Ref. no.	Pitch p (")	Pitch p (mm)	Breaking load F_B				Chain components and connecting links Nos.	Inner link			Outer link			Transverse pitch e (mm)	
					iwis (N) ave.	Norm (N) min.	Bearing area f (cm ²)	Weight per m q (kg/m)		b_1 (mm) min.	b_2 (mm) max.	g (mm) max.	a_1 (mm) max. ²⁾	a (mm) max. ²⁾	Roller d_1 (mm) max.		Pin d_2 (mm) max.
Simplex																	
08 A-1	L 85 A	ANSI 40	1/2"	12,70	18.000	14.100	0,44	0,60	2, 3, 6, 7, 8	7,94	11,15	12,00	16,60	17,50	7,95	3,96	-
10 A-1	M 106 A	ANSI 50	5/8"	15,875	29.000	22.200	0,70	1,00	2, 3, 6, 7, 8	9,53	13,84	14,40	20,40	21,70	10,16	5,08	-
12 A-1	M 128 A SL ¹⁾	ANSI 60	3/4"	19,05	42.000	31.800	1,06	1,47	2, 3, 4, 6, 7, 8	12,70	17,75	18,00	25,30	26,70	11,91	5,96	-
16 A-1	M 1610 A	ANSI 80	1"	25,40	68.000	56.700	1,79	2,57	2, 3, 4, 6, 7, 8	15,88	22,60	22,80	32,10	34,00	15,88	7,92	-
Duplex																	
08 A-2	D 85 A	ANSI 40-2	1/2"	12,70	36.000	28.200	0,88	1,19	2, 3, 4, 6, 7, 8	7,94	11,15	12,00	31,00	31,90	7,95	3,96	14,38
10 A-2	D 106 A	ANSI 50-2	5/8"	15,875	56.000	44.400	1,40	1,92	2, 3, 6, 7, 8	9,53	13,84	14,40	38,60	39,90	10,16	5,08	18,11
12 A-2	D 128 A ¹⁾	ANSI 60-2	3/4"	19,05	84.000	63.600	2,12	2,90	2, 3, 4, 6, 7, 8	12,70	17,75	18,00	48,10	49,50	11,91	5,96	22,78
16 A-2	D 1610 A	ANSI 80-2	1"	25,40	145.000	113.400	3,58	5,01	2, 3, 4, 6, 7, 8	15,88	22,60	22,80	61,40	63,30	15,88	7,92	29,29
Triplex																	
08 A-3	Tr 85 A	ANSI 40-3	1/2"	12,70	50.000	42.300	1,32	1,78	2, 3, 6, 7, 8	7,94	11,15	12,00	45,40	46,30	7,95	3,96	14,38
10 A-3	Tr 106 A	ANSI 50-3	5/8"	15,875	80.000	66.600	2,10	2,89	2, 3, 6, 7, 8	9,53	13,84	14,40	56,70	58,00	10,16	5,08	18,11
12 A-3	Tr 128 A	ANSI 60-3	3/4"	19,05	125.000	95.400	3,18	4,28	2, 3, 4, 6, 7, 8	12,70	17,75	18,00	71,00	72,30	11,91	5,96	22,78
16 A-3	Tr 1610 A	ANSI 80-3	1"	25,40	210.000	170.100	5,37	7,47	2, 3, 4, 6, 7, 8	15,88	22,60	22,80	90,70	92,70	15,88	7,92	29,29

iwis® Roller chains, double-pitch type

according to DIN 8181 and ISO 1275:1995

208 B	LR 165 SL	-	1"	25,40	22.000	18.000	0,50	0,52	2, 4, 6, 8	7,75	11,30	11,80	16,90	18,60	8,51	4,45	-
210 B	LR 206 SL	-	1 1/4"	31,75	28.000	22.400	0,67	0,63	2, 4, 6, 8	9,65	13,28	15,10	19,50	20,80	10,16	5,08	-
212 B	LR 247 SL	-	1 1/2"	38,10	34.000	29.000	0,89	0,85	2, 4, 6, 8	11,75	15,62	16,10	22,70	24,10	12,07	5,72	-
216 B	LR 3211	-	2"	50,80	75.000	60.000	2,10	2,10	2, 4, 6, 8	17,02	25,45	20,60	36,10	38,10	15,88	8,28	-

Roller Chains, double-pitch type

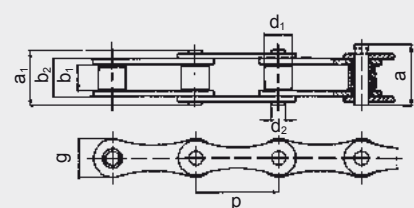

¹⁾ Also available with straight side plates ²⁾ Varying dimensions for cranked links

It should be noted that if cranked links are fitted, the breaking strength of the chain may be reduced by approximately 20%.

The suffix SL indicates chains with particularly wear-resistant pins.

iwis® High performance chains

Quality products with a world reputation

HIGH QUALITY IS BASED ON EACH INDIVIDUAL PART BEING TECHNICALLY PERFECT

- Use of high-grade heat-treatable steels which are made exclusively for iwis to their material analysis, tolerance and surface quality.
- Each chain part is manufactured a million times daily to the same precision. This production is monitored by SPC (statistical process control).
- All chain parts are heat-treated, using special processes to optimize quality features.
- Constant geometry and high surface quality result from the use of modern production technologies.
- Chains are checked for dimensional accuracy: length tolerance, freedom of articulation and assembly component integrity, inspection of the press-in seating of the pin outer links and bush-inner link interfaces.
- The high standard of quality assurance conforms with the high requirements of ISO 9001: 2006.
- For special applications
 - Surface coatings
 - Special lubrications
 - Reduced length tolerated chains
 - Special materials (e.g. corrosion resistant)

iwis side plate – optimally dimensioned, shaped with precision, and heat-treated for toughness and hardness.



iwis shouldered pin (DIN 8187). SL serie chains have pins with still higher resistance to wear.



iwis bush - manufactured as a special, surface treated cylinder and depending on the application seamless or curled

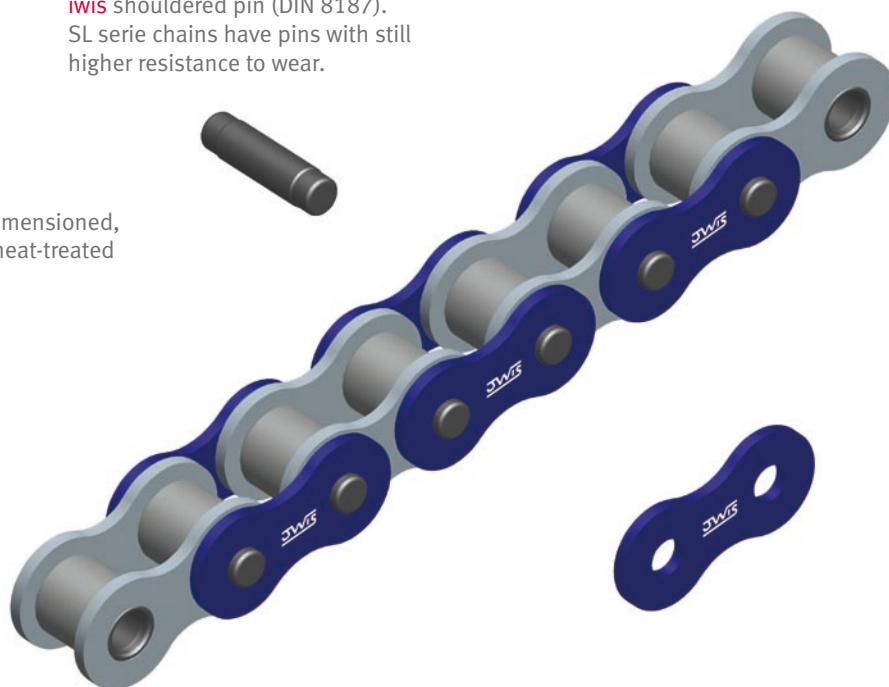

iwis roller – an absolutely cylindrical form guarantees ideal sliding-contact bearing properties.

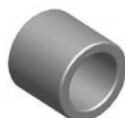



JWTS[®] Conveyor chains

iwis conveyor chains can especially be matched with the demands of customer applications. iwis does not only supply the customer with a wide range of special straight attachments and bent attachment plates, but the Technical Service Team offers solutions for individual customer demands and designs custom-made products.

iwis conveyor chains offer the user the benefits of parallel and synchronous running, extremely precise positioning, quiet running and a significantly higher breaking resistance than the norm. Also available: conveyor chains with extended bearing pins, conveyor chains with U-shaped attachments and multiple strand connecting links.



iwis® Conveyor chains with straight attachment plates for fitting to iwis chains DIN 8187, 8188 and 8181

DIN/ISO no.	Ref. no. iwis	Pitch ²⁾		a (mm)	b (mm)	d (mm)	Single strand chains e ₁ (mm)	Double strand chains e ₂ (mm)	Triple strand chains e ₃ (mm)	g (mm)	i (mm)	l (mm)	s (mm)	M (mm)	Threaded insert m. max (mm)
		p (")	p (mm)												
Plate No. 102.1															
-	P 83 V	1/2"	12,7	13,0	19,0	4,2	8,1	-	-	4,5	-	18,0	1,5	-	-
-	S 84 V	1/2"	12,7	13,0	19,0	4,2	9,8	-	-	4,5	-	18,0	1,5	-	-
08 B-1	L 85 SL ¹⁾	1/2"	12,7	13,0	19,0	4,2	11,6	25,5	39,4	5,4	-	18,0	1,5	4	5,2
10 B-1	M 106 SL ¹⁾	5/8"	15,875	16,3	24,3	5,2	13,6	30,1	46,6	6,8	-	24,0	1,6	5	5,3
12 B-1	M 127 SL ¹⁾	3/4"	19,05	19,1	29,1	6,2	15,9	35,3	54,7	7,4	-	28,0	1,8	5	5,5
16 B-1	M 1611 ¹⁾	1"	25,4	24,6	36,6	8,2	25,9	57,8	89,7	10,4	-	36,2	3,0	6	8,2
08 A-1 ANSI 40	L 85 A ¹⁾	1/2"	12,7	13,0	19,0	4,2	11,4	25,8	40,2	4,5	-	18,0	1,5	-	-
10 A-1 ANSI 50	M 106 A ¹⁾	5/8"	15,875	16,3	24,3	5,2	14,1	32,3	50,4	6,8	-	24,0	1,6	-	-
12 A-1 ANSI 60	M 128 A SL ¹⁾	3/4"	19,05	19,1	29,1	6,2	18,1	40,8	63,6	7,4	-	28,0	2,4	-	-
16 A-1 ANSI 80	M 1610 A ¹⁾	1"	25,4	24,6	36,6	8,2	23,0	52,2	81,5	10,4	-	36,2	3,0	-	-
Plate No. 103.1 and 103.2															
-	P 83 V ²⁾	1/2"	12,7	17,0	23,0	4,2	8,1	-	-	4,5	12,7	23,6	1,5	-	-
-	S 84 V	1/2"	12,7	17,0	23,0	4,2	9,8	-	-	4,5	12,7	23,6	1,5	-	-
08 B-1	L 85 SL ¹⁾	1/2"	12,7	17,0	23,0	4,2	11,6	25,5	39,4	5,4	12,7	23,6	1,5	4	5,2
10 B-1	M 106 SL ¹⁾	5/8"	15,875	16,3	25,8	5,2	13,6	30,1	46,6	7,5	15,8	31,0	1,6	5	5,3
12 B-1	M 127 SL ¹⁾	3/4"	19,05	18,3	29,0	6,2	15,9	35,3	54,7	9,0	19,0	37,2	1,8	5	5,5
16 B-1	M 1611 ¹⁾	1"	25,4	28,45	41,55	8,2	25,9	57,8	89,7	10,35	25,4	47,2	3,0	6	8,2
08 A-1 ANSI 40	L 85 A ¹⁾	1/2"	12,7	17,0	23,0	4,2	11,4	25,8	40,2	4,5	12,7	23,6	1,5	-	-
10 A-1 ANSI 50	M 106 A ¹⁾	5/8"	15,875	16,3	25,8	5,2	14,1	32,3	50,4	7,5	15,8	31,0	1,6	-	-
12 A-1 ANSI 60	M 128 A SL ¹⁾	3/4"	19,05	18,3	29,0	6,2	18,1	40,8	63,6	9,0	19,0	37,2	2,4	-	-
16 A-1 ANSI 80	M 1610 A ¹⁾	1"	25,4	28,45	41,55	8,2	23,0	52,2	81,5	10,35	25,4	47,2	3,0	-	-
Plate No. 101.1 and 101.2															
208 B	LR 165 SL	1"	25,4	14,3	20,5	4,2	11,6	-	-	6,5	14,0	24,2	1,5	-	-
210 B	LR 206 SL	1 1/4"	31,75	16,3	25,8	5,2	13,8	-	-	7,5	18,0	30,2	1,6	-	-
212 B	LR 247 S	1 1/2"	38,1	19,2	29,5	6,2	15,9	-	-	9,0	20,0	36,2	1,7	-	-
216 B	LR 3211	2"	50,8	28,5	40,6	8,2	25,9	-	-	10,2	28,0	48,2	3,0	-	-

¹⁾ Available for both double and triple strand chains ²⁾ Nominal pitch

iwis® Conveyor chains with straight attachment plates for fitting to iwis chains DIN 8187, 8188 and 8181

STRAIGHT ATTACHMENT PLATES

The designs shown below can be supplied as connecting links, or outer links for end

fitting or repair. Further threaded inserts can also be supplied. Details on request.

Single

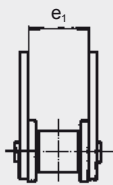

Double

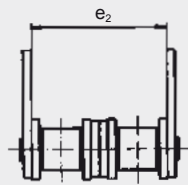

Triple

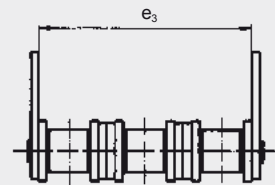

102.1

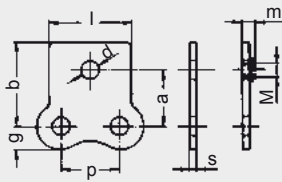

102.31 with threaded insert

103.1

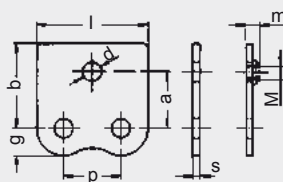

103.2

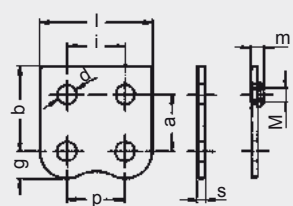

103.32 with threaded insert

101.1 for double-pitch chains

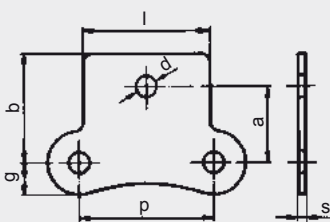

101.2 for double-pitch chains

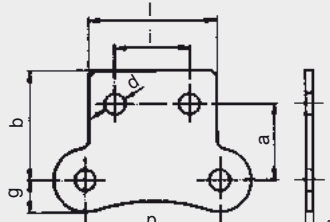

iwis® Conveyor chains with bent attachment plates for fitting to iwis chains DIN 8187, 8188 and 8181

DIN ISO no.	Ref. no. iwis	Pitch				Single chains		Double chains			Triple chains					Threaded insert		
		p (Zoll)	p (mm)	c (mm)	d (mm)	e ₁ (mm)	f ₁ (mm)	e ₂ (mm)	f ₂ (mm)	e ₃ (mm)	f ₃ (mm)	g (mm)	h (mm)	i (mm)	l (mm)	s (mm)	M (mm)	m max. (mm)
Form 202.1																		
-	P 83 V	1/2"	12,7	8,0	4,2	24,1	36,1	-	-	-	-	4,5	14,0	-	18,1	1,5	-	-
-	S 84 V	1/2"	12,7	8,0	4,2	25,8	37,8	-	-	-	-	4,5	14,0	-	18,1	1,5	-	-
08 B-1	L 85 SL ¹⁾	1/2"	12,7	8,0	4,2	27,6	39,6	41,5	53,5	55,4	67,4	5,4	14,0	-	18,1	1,5	4	5,2
10 B-1	M 106 SL ¹⁾	5/8"	15,875	9,0	5,2	33,6	49,6	50,1	66,1	66,6	82,6	6,8	18,0	-	24,0	1,6	5	5,3
12 B-1	M 127 SL ¹⁾	3/4"	19,05	10,0	6,2	41,1	61,1	60,5	80,5	79,9	99,9	7,4	22,6	-	28,0	1,8	5	5,5
16 B-1	M 1611 ^{1) 2)}	1"	25,4	16,0	8,2	53,9	77,9	85,8	109,8	117,7	141,7	10,4	26,0	-	36,2	3,0	6	8,2
08 A-1 ANSI 40	L 85 A ¹⁾	1/2"	12,7	8,0	4,2	27,4	39,4	41,8	53,8	56,2	68,2	4,5	14,0	-	18,1	1,5	-	-
10 A-1 ANSI 50	M 106 A ¹⁾	5/8"	15,875	9,0	5,2	34,1	50,1	52,3	68,3	70,4	86,4	6,8	18,0	-	24,0	1,6	-	-
12 A-1 ANSI 60	M 128 A SL ¹⁾	3/4"	19,05	13,0	6,2	38,9	58,9	61,6	81,6	84,4	104,4	7,4	20,4	-	28,0	2,4	-	-
16 A-1 ANSI 80	M 1610 A ^{1) 2)}	1"	25,4	16,0	8,2	51,0	75,0	80,2	104,2	109,5	133,5	10,4	26,0	-	36,2	3,0	-	-
Form 203.1 and 203.2																		
-	P 83 V ²⁾	1/2"	12,7	9,5	4,2	29,1	41,1	-	-	-	-	4,5	16,5	12,7	23,6	1,5	-	-
-	S 84 V ²⁾	1/2"	12,7	9,5	4,2	30,8	42,8	-	-	-	-	4,5	16,5	12,7	23,6	1,5	-	-
08 B-1	L 85 SL ^{1) 2)}	1/2"	12,7	9,5	4,2	32,6	44,6	46,5	58,5	60,4	72,4	5,4	16,5	12,7	23,6	1,5	4	5,2
10 B-1	M 106 SL ^{1) 2)}	5/8"	15,875	11,0	5,2	30,6	49,6	47,1	66,1	63,6	82,6	7,5	18,0	15,8	31,0	1,6	5	5,3
12 B-1	M 127 SL ^{1) 2)}	3/4"	19,05	12,0	6,2	35,5	56,9	54,9	76,3	74,3	95,7	9,0	20,5	19,0	37,2	1,8	5	5,5
16 B-1	M 1611 ^{1) 2)}	1"	25,4	18,0	8,2	57,7	83,9	89,6	115,8	121,5	147,8	10,4	29,0	25,4	47,2	3,0	6	8,2
08 A-1 ANSI 40	L 85 A ^{1) 2)}	1/2"	12,7	9,5	4,2	32,4	44,4	46,8	58,8	61,2	73,2	4,5	16,5	12,7	23,6	1,5	-	-
10 A-1 ANSI 50	M 106 A ^{1) 2)}	5/8"	15,875	11,0	5,2	31,1	50,1	49,3	68,3	67,3	86,4	7,5	18,0	15,8	31,0	1,6	-	-
12 A-1 ANSI 60	M 128 A SL ^{1) 2)}	3/4"	19,05	13,0	6,2	37,3	58,7	60,0	81,4	82,8	104,2	9,0	20,3	19,0	37,2	2,4	-	-
16 A-1 ANSI 80	M 1610 A ^{1) 2)}	1"	25,4	18,0	8,2	54,8	81,0	84,0	110,2	113,3	139,5	10,4	29,0	25,4	47,2	3,0	-	-
Form 201.1 and 201.2																		
208 B	LR 165 SL ²⁾	1"	25,4	10,0	4,2	26,2	38,6	-	-	-	-	6,5	13,5	14,0	24,2	1,5	-	-
210 B	LR 206 SL ²⁾	1 1/4"	31,75	11,0	5,2	30,6	49,6	-	-	-	-	7,5	18,0	18,0	30,2	1,6	-	-
212 B	LR 247 SL ²⁾	1 1/2"	38,1	13,0	6,2	34,9	55,5	-	-	-	-	9,0	19,8	20,0	36,2	1,7	-	-
216 B	LR 3211 ²⁾	2"	50,8	18,0	8,2	57,7	81,9	-	-	-	-	10,2	28,0	28,0	48,2	3,0	-	-

¹⁾ Available also for corresponding double and triple strand chains ²⁾ The bent attachment plates can also be fitted facing inwards with the top part

iwis® Conveyor chains with bent attachment plates for fitting to iwis chains DIN 8187, 8188 and 8181

BENT ATTACHMENT PLATES

The designs shown below can be supplied as connecting links, or outer links for end fitting or repair.

When the attachment is fitted facing inwards over the chain, threaded inserts

cannot be used. Further threaded inserts can also be supplied. Details on request.

Single

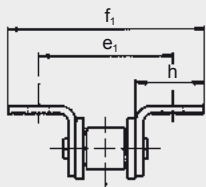

Double

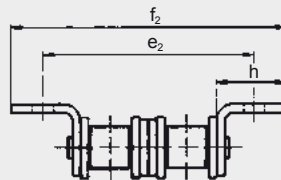

Triple

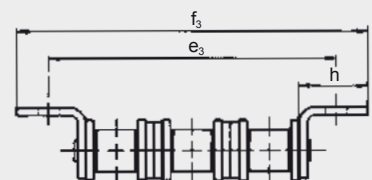

202.1

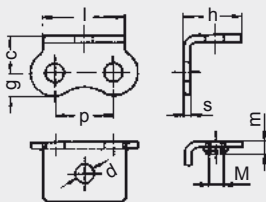

202.31 with threaded insert

203.1

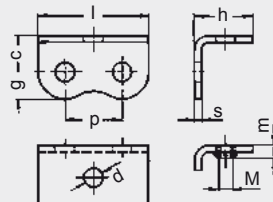

203.31 with threaded insert

203.2

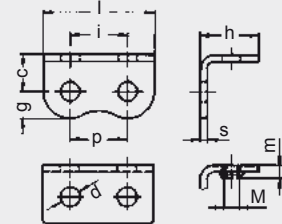

203.32 with threaded insert

201.1 for double-pitch chains

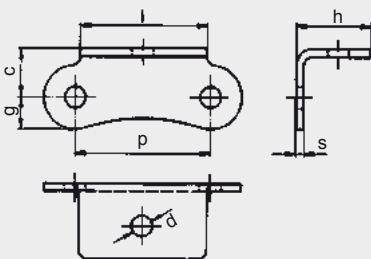

201.2 for double-pitch chains

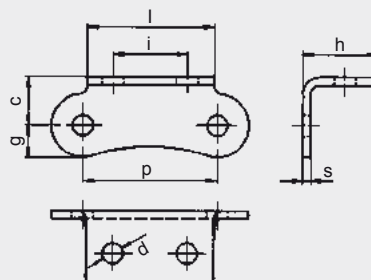

iwis® Conveyor chains

Special straight attachment plates – examples

For chain G 52: Form 103.7

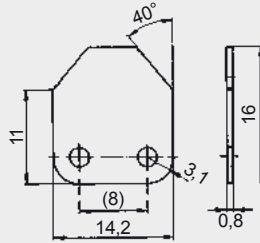

For chain G 52: Form 121.0

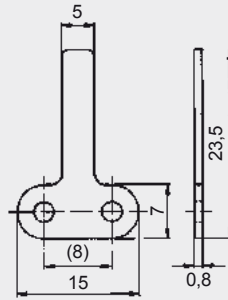

For chain L 85 SL: Form 103.62

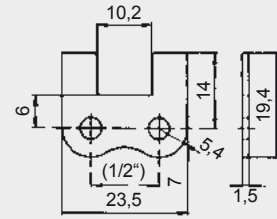

For chain L 85 SL: Form 103.63

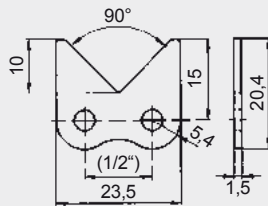

For chain L 85 SL: Form 103.65

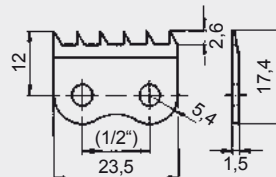

For chain L 85 SL: Form 106.0
Guide plates for inner links

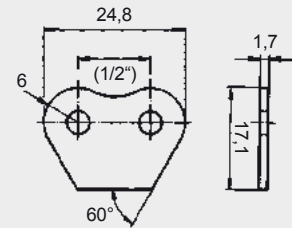

For chain L 85 SL: Form 110.0

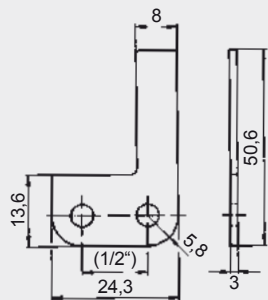

For chain L 85 SL: Form 112.0

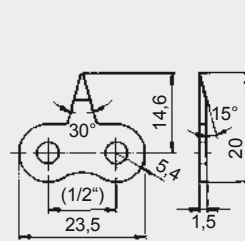

For chain L 85 SL: Form 120.11

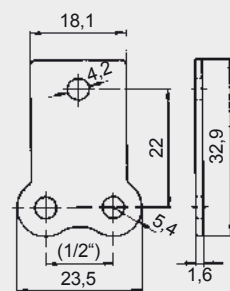

For chain L 85 SL: Trip or cam plate

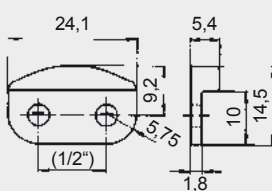

For chain M 106 SL: Form 102.71

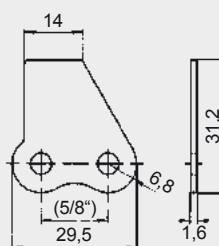

For chain M 127 SL: Form 102.61

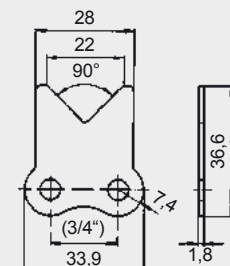

iwis® Conveyor chains

Special straight attachment plates – examples

For chain M 127 SL: Form 122.21

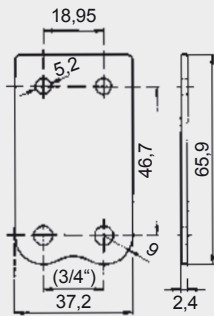

For chain M 128 A SL: Form 103.64

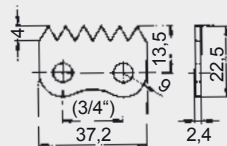

For chain M 128 A SL: Form 119.1

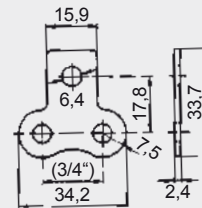

For chain M 127 SL: Form 102.65

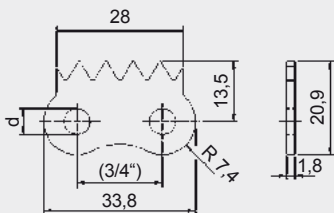

For chain L 85 SL: Form 103.52

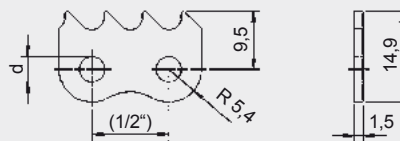

For chain M 127 A SL: Form 103.64

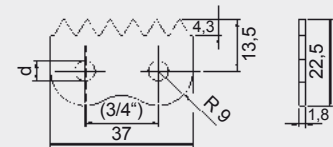

For chain M 128 A SL: Form 103.64

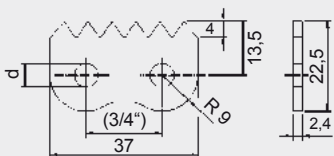

For chain L 85 SL: Form 103.67

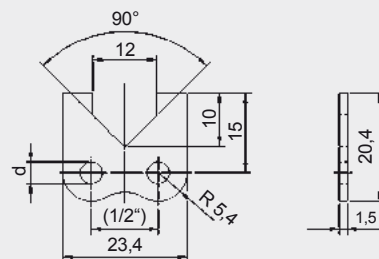

For chain L 85 SL: Form 112.10

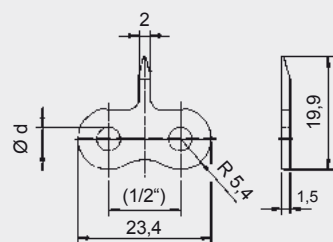

For chain L 85 SL: Form 131.12

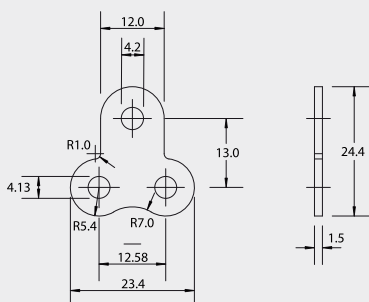

For chain L 85 SL: Form 112.09

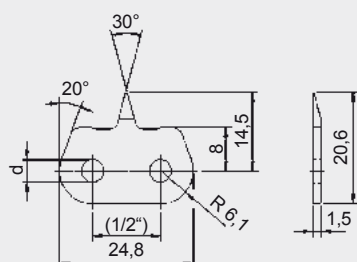

For chain L 85 SL: Form 132.0

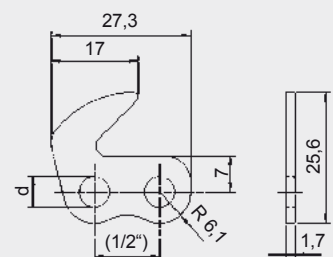

iwis® Conveyor chains

Special bent attachment plates – examples

For chain L 85 SL: Form 203.8

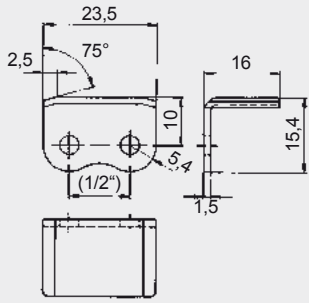

For chain L 85 SL: Form 220.11

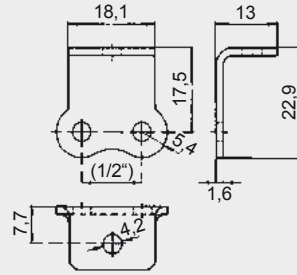

For chain M 106 SL: Form 220.13

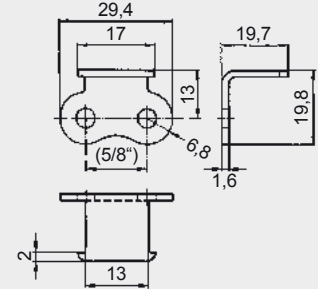

For chain M 106 SL: Form 202.6

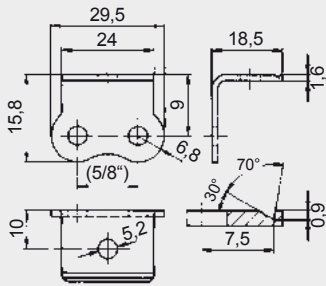

For chain M 127 SL: Form 203.8

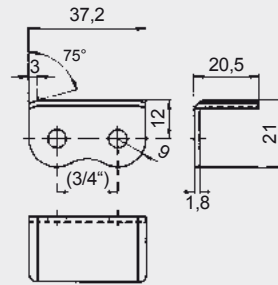

For chains M 128 A SL/M 128 A SB, Form 222.2

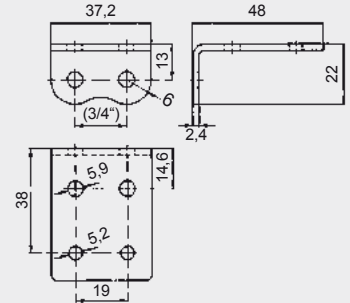

For chain M 128 A SL: Form 202.3

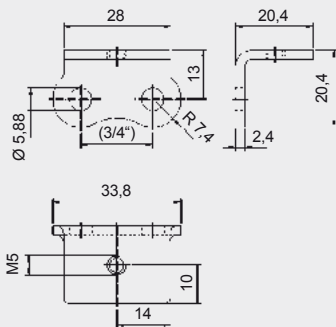

For chain M 128 A SL: Form 202.8

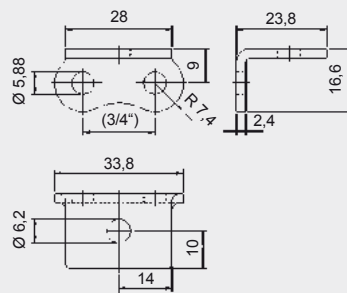

For chains M 1610 A and M 1611 SL: Form 202.13

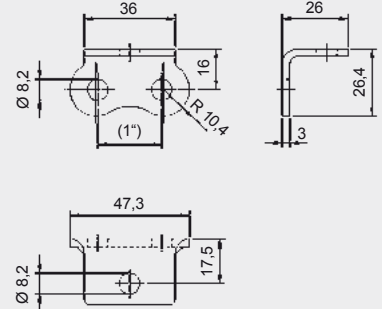

For chain M 127 SL: Form 203.12

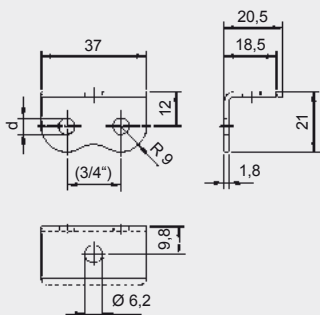

For chain M 106 SL: Form 203.17

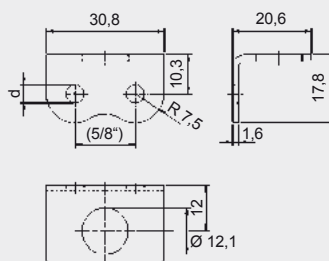

For chain L 85 SL: Form 203.32

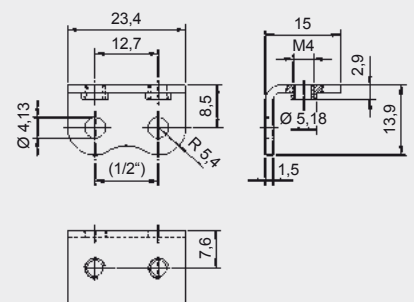

Similar attachment plate designs for other chain types are available on request, as are other attachment plate designs. For some special attachment plates minimum order quantities are required.

iwis® Conveyor chains extended bearing pins for fitting to iwis chains DIN 8187, 8188 and 8181

DIN ISO no.	Ref. no. iwis ¹⁾	p (")	Pitch p (mm)	inner width b ₁ (mm)	Roller diameter d ₁ (mm)	Extended bearing pin diameter d ₂ (mm)	Design A pin length		Design B and C pin length			
							L ₁ (mm)	l ₁ (mm)	L ₂ (mm)	l ₂ (mm)	l ₃ (mm)	
Pin design A, B, C												
05 B-1	G 52	-	8,0	3,16	5,0	2,31	17,5	10,0	27,5	20,0	10,5	
06 B-1	G 67	3/8"	9,525	5,72	6,35	3,31	22,0	10,0	34,0	22,0	11,5	
-	P 83 V	1/2"	12,7	4,88	7,75	3,68	22,0	10,0	37,0	25,0	13,0	
08 B-1	L 85 SL	1/2"	12,7	7,75	8,51	4,45	25,5	10,0	40,5	25,0	13,0	
10 B-1	M 106 SL	5/8"	15,875	9,65	10,16	5,08	30,0	12,0	48,0	30,0	15,5	
12 B-1	M 127 SL	3/4"	19,05	11,75	12,07	5,72	36,0	15,0	51,0	30,0	15,5	
16 B-1	M 1611	1"	25,4	17,02	15,88	8,28	53,5	20,0	68,5	35,0	18,0	
08 A-1 ANSI 40	L 85 A	1/2"	12,7	7,94	7,95	3,96	25,5	10,0	45,3	30,0	15,5	
10 A-1 ANSI 50	M 106 A	5/8"	15,875	9,53	10,16	5,08	31,5	12,0	48,0	29,0	15,0	
12 A-1 ANSI 60	M 128 A SL	3/4"	19,05	12,70	11,91	5,96	38,0	14,0	48,0	24,0	12,5	
16 A-1 ANSI 80	M 1610 A	1"	25,4	15,88	15,88	7,92	49,5	19,0	61,3	31,0	16,0	
208 B	LR 165 SL	1"	25,4	7,75	8,51	4,45	25,5	10,0	40,5	25,0	13,0	
210 B	LR 206 SL	1 1/4"	31,75	9,65	10,16	5,08	30,0	12,0	48,0	30,0	15,5	
212 B	LR 247 SL	1 1/2"	38,1	11,75	12,07	5,72	36,0	15,0	51,0	30,0	15,5	
216 B	LR 3211	2"	50,8	17,02	15,88	8,28	53,5	20,0	68,5	35,0	18,0	

¹⁾ For multiple strand chains on request. Other pin designs and lengths available on request.

EXTENDED BEARING PINS

The designs shown below can be supplied as connecting links or outer links for end fitting or repair (C only as outer link).

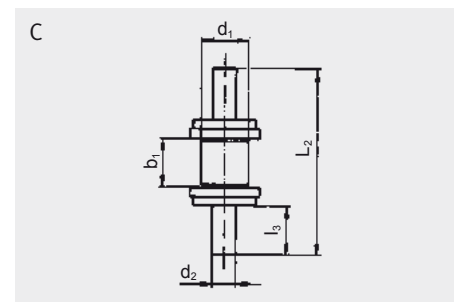
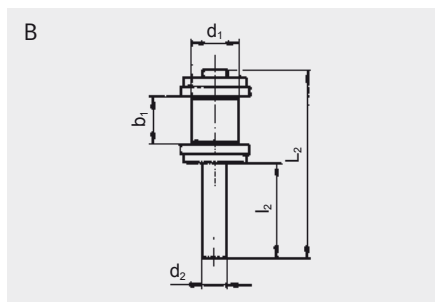
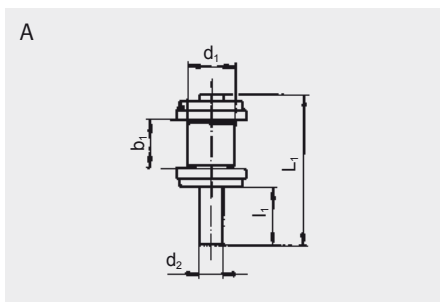

iwis® Multiple strand connecting links for attachment of components ¹⁾

DIN/ISO no.	Ref. no. iwis	Chain p (")	Pitch Pitch of holes in component (mm)	Inside width b_1 (mm)	Roller diameter d_1 (mm)	Pin diameter d_2 (mm)	a_2 (mm)	Outside width a_3 (mm)	Block width A_2 (max. mm)	A_3 (max. mm)
Double										
05B-1	G 52	8 mm	7,94	3,16	5,0	2,31	14,9	-	4,0	-
06B-1	G 67	3/8	9,42	5,72	6,35	3,31	24,5	34,6	7,0	17,5
Double / Triple										
08B-1	L 85 SL	1/2	12,58	7,75	8,51	4,45	32,3	46,2	11,3	25,2
10B-1	M 106 SL	5/8	15,76	9,65	10,16	5,08	37,4	53,9	13,3	29,9
12B-1	M 127 SL	3/4	18,95	11,75	12,07	5,72	42,9	62,4	15,6	35,1
16B-1	M 1611	1	25,3	17,02	15,88	8,28	68,7	100,6	25,5	57,4
08 A-1 ANSI 40	L 85 A	1/2	12,58	7,94	7,95	3,96	31,8	46,2	11,2	25,5
10 A-1 ANSI 50	M 106 A	5/8	15,76	9,53	10,16	5,08	39,8	57,9	13,8	32,0
12 A-1 ANSI 60	M 128 A SL	3/4	18,95	12,70	11,91	5,96	49,4	72,2	17,8	40,6
16 A-1 ANSI 80	M 1610 A	1	25,3	15,88	15,88	7,92	63,2	92,6	22,6	51,9

¹⁾ Please note the exact pitch measure „p“ for the assembly of special components.

EXAMPLES

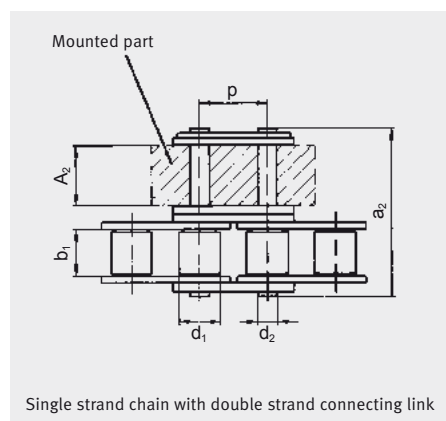

Multiple strand connecting links permit components to be fitted easily at specific locations on the chain.

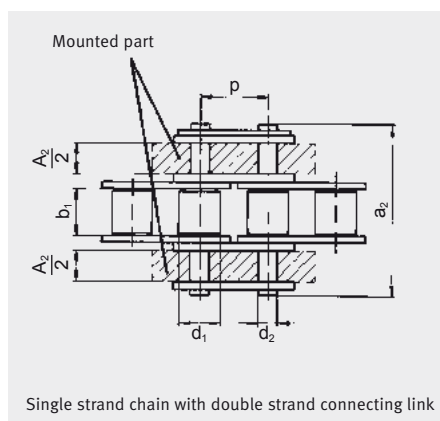

Multiple strand connecting links can be supplied with normal side plates or as connecting links with straight or bent attachment plates, mounted on one or both sides.

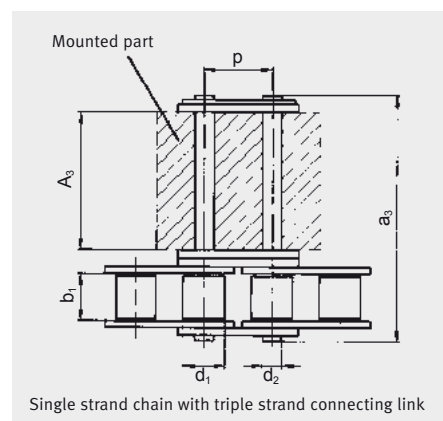

Note: The pitch of holes in the mounted part (component) differ from chain pitch.

iwis® Conveyor chains with U-shaped attachments

for fitting to iwis roller chains DIN 8187 and 8188

DIN/ISO no.	Ref. no. iwis	Pitch p (mm)	A (mm)	B (mm)	a (mm)	c (mm)	d' (mm)	g (mm)	h (mm)	i (mm)	k (mm)	l (mm)	s (mm)	M (mm)	Threaded insert m max. (mm)
U-shaped attachment 303.2 / 303.32 / 303.9															
08B-1	L 85 SL	12,7	17,8	19,8	21,5	9,5	4,1	6,3	14,6	12,6	3,0	24,2	1,5	4	5,2
08B-2	D 85 SL	12,7	31,8	33,9	35,5	9,5	4,1	6,3	28,5	13,9	3,0	24,2	1,5	4	5,2
10B-1	M 106 SL	15,875	20,0	22,0	24,0	12,0	7,1	7,5	16,6	15,8	3,0	31,0	1,5	5	5,2
16 A-1 ANSI 80	M 1610 A	25,4	33,7	36,5	38,4	16,2	8,7	10,5	27,3	25,3	5,0	49,2	2,1	6	7,3

¹⁾ Alternative diameters: for L 85 SL: 5,8 mm / for M 106 L: 4,7 mm

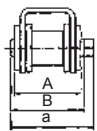

Chain width:

When U-shaped attachments are fitted between the inner and outer plates, the chain width increases above the norm.
 a = pin length of connecting link

Form 303.2 with standard attachment holes

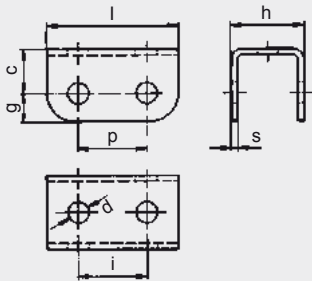

Form 303.32 with threaded inserts

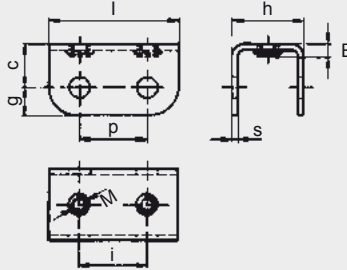

With D 85 SL threaded inserts are positioned transversely to the chain

Form 303.9 with rubber cover

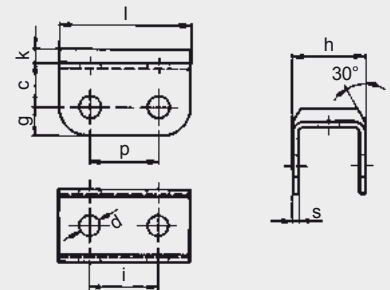

Cover material: Perbunan
 Hardness: 65 Shore / Temperature: -30 up to +100 °C

SPECIAL DESIGNS

1"-double strand chain with special U-shaped attachment. Base chain: iwis M 1610 A

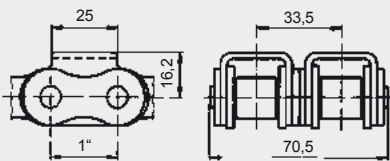

No. 303.94 for chain D 85 SL

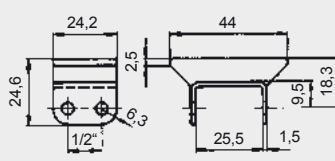

No. 303.97 for chain L 85 SL

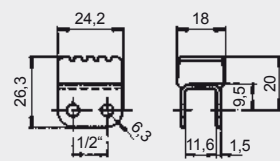

JWTS[®] MEGAlife

MEGAlife maintenance free roller and conveyor chains can be applied in all areas where post installation lubrication is not at all or only partly possible. This is the case in clean and dry surroundings or in applications with difficult lubrication passage. MEGAlife maintenance free chains are corrosion resistant due to nickel-plated parts and can be utilized in a temperature range from -40°C up to $+160^{\circ}\text{C}$. The chains are supplied either dry or with special-purpose lubrication in line with the requirements of the applied application.





iwis® MEGAlife I and MEGAlife II

The maintenance free iwis chains

PROBLEM/INITIAL SITUATION

- Lubrication is not at all or only partly possible
- Clean & dry surroundings are required
- Difficult/obstructed lubrication passage
- Contamination of manufacturing outlet and conveyor apparatus due to chain lubrication

OUR SOLUTION

A high performance, maintenance-free chain with redesigned joints. Innovative technical details which result in an, as yet, unbeatable service life, even without re-lubrication.

CUSTOMER BENEFITS

- Excellent wear resistance – even at high speeds and loads – where conventional maintenance free chains stretch
- Extremely high levels of fatigue and breaking strength
- Easy to dismantle
- Reduced overall maintenance cost
- Less production still-time
- Environmentally-friendly due to absence of excess lubrication
- Protected from corrosion
- Installations have fewer down times
- Environmentally friendly because lubrication is not necessary

TECHNICAL FEATURES

- Available dry or with additional special lubricant
- Corrosion resistant
- Temperature range from -40 °C up to +160 °C
- Available as roller chain according to ISO 606 for driving purposes or as conveyor chain with attachments and extended components.

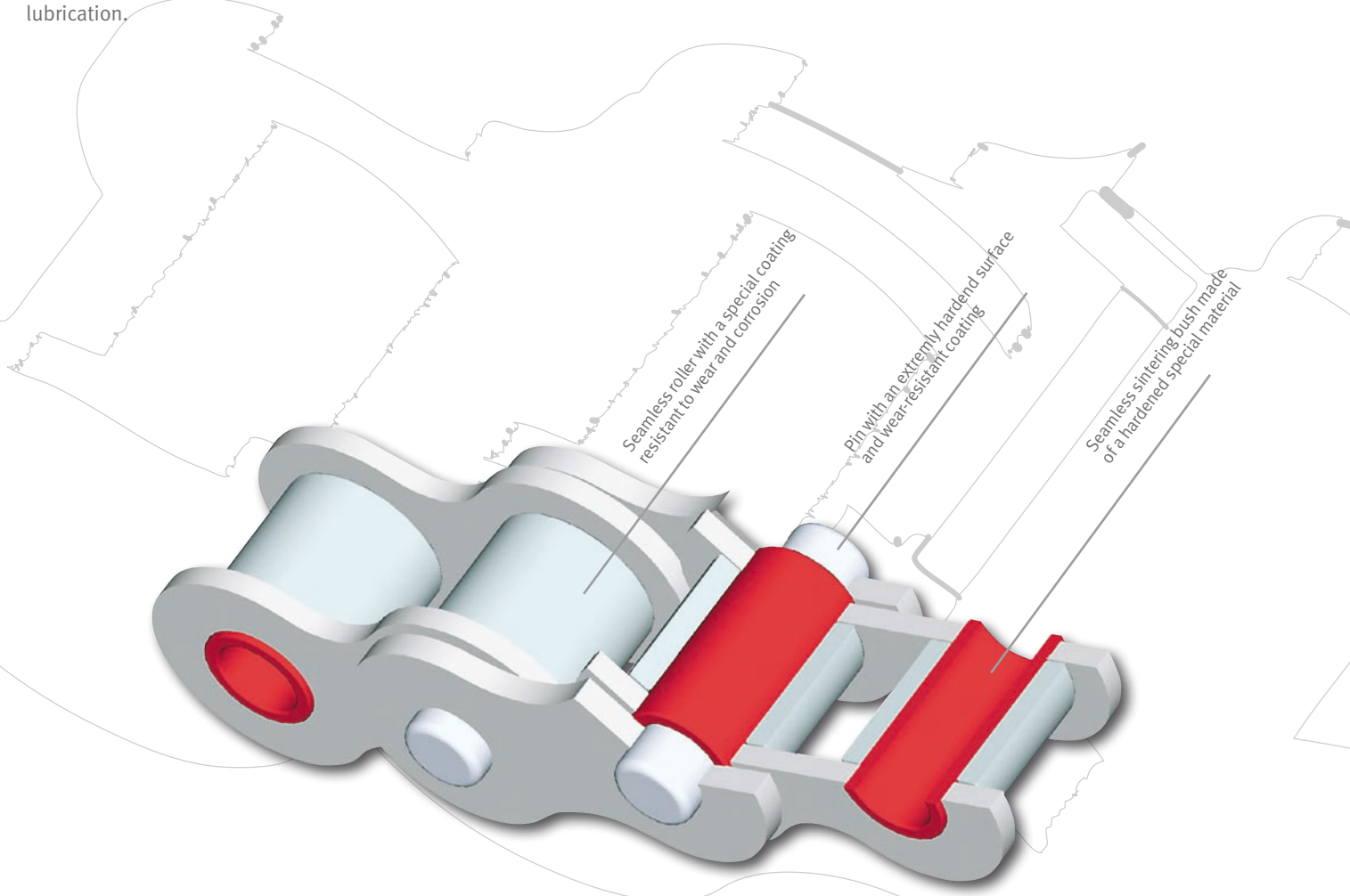



HIGHLIGHTS MEGALIFE I

- Excellent wear resistance – even at high speeds and loads – where conventional maintenance free chains stretch
- Maintenance free under certain conditions
- Extremely high levels of fatigue and breaking strength
- Protected from corrosion
- Easy to dismantle
- Reduced overall maintenance cost
- Less production still-time
- Environmentally friendly because lubrication is not necessary

HIGHLIGHTS MEGALIFE II

- A distinctive longer lifetime due to:
- A considerably improved wear resistance as a result of a special thermo-chemical treatment of the pins. Especially by fast running chain drives $v > 3 \text{ m/s}$

AREAS OF APPLICATION

- Packaging & Food Industry
- Printing Industry
- Conveyor-Equipment
- Textile & Clothing Industry
- Paper Manufacture & Book Binding Industry
- Electronic Industry & Circuit Board Manufacture
- Wood, Glass & Ceramic Industry
- Medical technology

... and of course in all areas where re-lubrication is not at all or only partly possible.

Trial without re-lubrication at high speeds.
 Graphic representation corresponds to iwis test results.

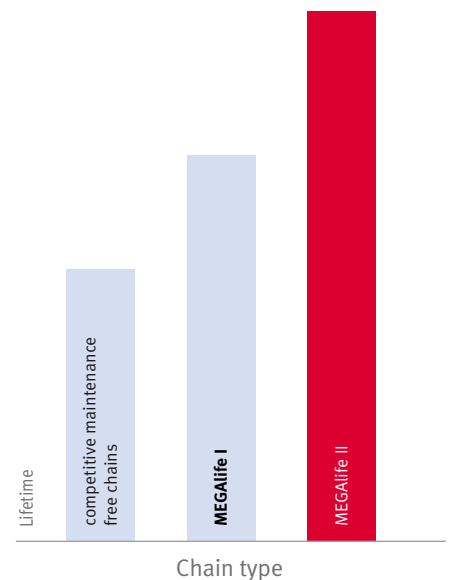
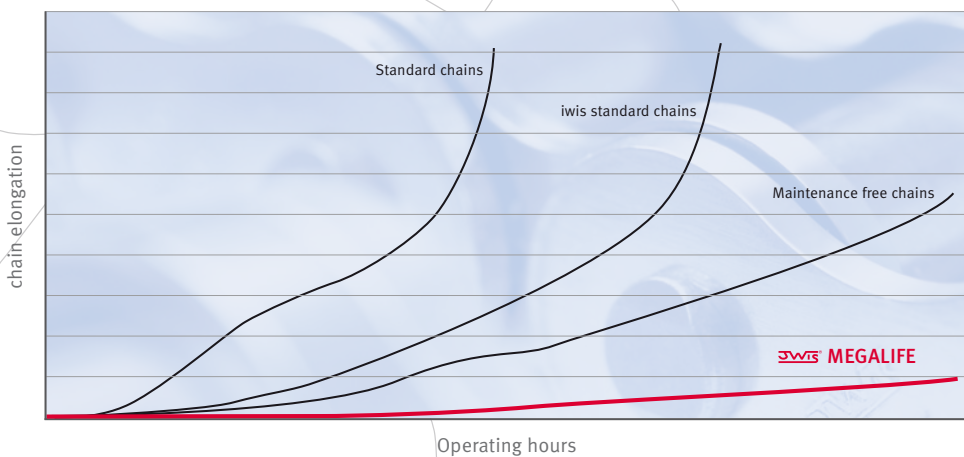

iwis® MEGAlife I roller chains

Complying with DIN 8187-1, ISO 606: 2004

DIN/ISO no.	Ref. no. iwis	Pitch p (")	Pitch p (mm)	iwis (N) med.	Breaking strength (N) min. Standard	Breaking area F (cm ²)	Weight per m q (kg/m)	b ₁ (mm) min.	b ₂ (mm) min.	g (mm) max.	Inner link a ₁ (mm) max. ¹⁾	Outer link a (mm) max. ¹⁾	Roller d ₁ (mm) max.	Pin d ₂ (mm) max.	Transverse pitch e (mm)	Article No.
Simplex																
06 B-1	G 67 ML*	3/8"	9,525	11.000	9.000	0,28	0,41	5,72	8,53	8,20	12,90	16,70	6,35	3,31	-	50033917
08 B-1	L 85 ML	1/2"	12,70	22.000	18.000	0,50	0,70	7,75	11,30	12,20	16,90	18,50	8,51	4,45	-	50026256
08 A-1 ANSI 40	L 85 AML	1/2"	12,70	17.500	14.100	0,44	0,60	7,94	11,15	12,00	16,60	17,50	7,95	3,96	-	50036841
10 B-1	M 106 ML	5/8"	15,875	25.000	22.400	0,67	0,95	9,65	13,28	14,40	19,50	20,90	10,16	5,08	-	50026257
12 B-1	M 127 ML	3/4"	19,05	30.000	29.000	0,89	1,25	11,75	15,62	16,20	22,70	23,60	12,07	5,72	-	50026258
12 A-1 ANSI 60	M 128 AML	3/4"	19,05	41.000	31.800	1,06	1,47	12,70	17,75	18,00	25,30	26,70	11,91	5,96	-	50038464
16 B-1	M 1611 ML	1"	25,4	75.000	60.000	2,10	2,70	17,02	25,45	21,10	36,10	36,90	15,88	8,28	-	50028923
Duplex																
06 B-2	D 67 ML	3/8"	9,525	19.000	16.900	0,56	0,78	5,72	8,53	8,20	23,40	24,60	6,35	3,31	10,24	50033832
08 B-2	D 85 ML	1/2"	12,70	40.000	32.000	1,00	1,35	7,75	11,30	12,20	30,80	32,40	8,51	4,45	13,92	50027439
10 B-2	D 106 ML	5/8"	15,875	50.000	44.500	1,34	1,85	9,65	13,28	14,40	36,00	37,50	10,16	5,08	16,59	50027509
12 B-2	D 127 ML	3/4"	19,05	60.000	57.800	1,78	2,50	11,75	15,62	16,40	42,10	43,00	12,07	5,72	19,46	50027457
16 B-2	D 1611 ML	1"	25,40	150.000	106.000	4,21	5,40	17,02	29,45	21,10	68,00	68,80	15,85	8,28	31,88	50033161
20 B-2	D 2012 ML	1 1/4"	31,75	210.000	170.000	5,84	7,36	19,56	29,01	25,40	79,70	82,90	19,05	10,19	36,45	50033771
Triplex																
08 B-3	TR 85 ML	1/2"	12,70	58.000	47.500	1,50	2,00	7,75	11,30	12,20	44,70	46,30	8,51	4,45	13,92	50027510
10 B-3	TR 106 ML	5/8"	15,875	75.000	66.700	2,02	2,80	9,65	13,28	14,40	52,50	54,00	10,16	5,08	16,59	50027511
12 B-3	TR 127 ML	3/4"	19,05	89.000	86.700	2,68	3,80	11,75	15,62	16,40	61,50	62,50	12,07	5,72	19,46	50027512
16 B-3	TR 1611 ML	1"	25,40	219.000	160.000	6,32	8,00	17,02	25,45	21,10	99,20	100,70	15,88	8,28	31,88	50033628
Simplex/duplex - MEGAlife roller chains with straight side plates																
10 B-1	M 106 ML-GL	5/8"	15,875	24.000	22.400	0,67	0,95	9,65	13,28	13,90	19,50	20,90	10,16	5,08	-	50035304
10 B-2	D 106 ML-GL	5/8"	15,875	47.500	44.500	1,34	1,85	9,65	13,28	13,90	36,00	37,50	10,16	5,08	16,59	50034083
12 B-1	M 127 ML-GL	3/4"	19,05	30.000	29.000	0,89	1,30	11,75	15,62	16,10	22,70	23,60	12,07	5,72	-	50037351
12 B-2	D 127 ML-GL	3/4"	19,05	63.000	57.800	1,78	2,50	11,75	15,62	16,10	42,10	43,00	12,07	5,72	19,46	50034084

* also available in 10 m length (Art. 50035181), with straight side plates ¹⁾ Differing dimensions for cranked links If cranked links are fitted, it should be noted that the breaking strength of the chain may be reduced by approximately 20%.

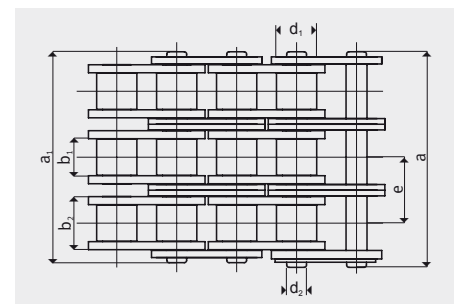
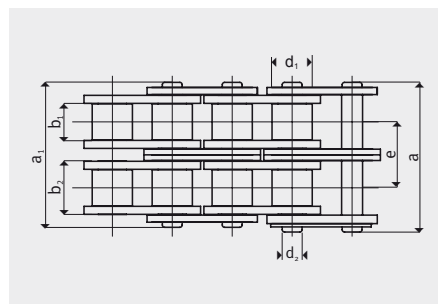
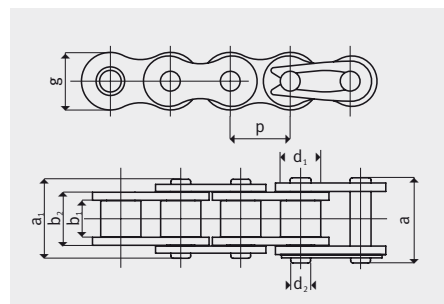

iwis® MEGAlife I conveyor chains with straight attachment plates

based on iwis roller chains complying with DIN 8187

DIN/ISO no.	Ref. no. iwis	p (°)	Pitch ²⁾			d (mm)	Simplex chains e ₁ (mm)	Duplex chains e ₂ (mm)	Triplex chains e ₃ (mm)	g (mm)	i (mm)	l (mm)	s (mm)	M (mm)	m max. (mm)	Threaded insert
			p (mm)	a (mm)	b (mm)											
Shape 102.1																
08 B-1	L 85 ML ¹⁾	1/2"	12,7	13,0	19,0	4,2	11,6	25,5	39,4	5,4	-	18,0	1,5	4	5,2	
10 B-1	M 106 ML ¹⁾	5/8"	15,875	16,3	24,3	5,2	13,6	30,1	46,6	6,8	-	24,0	1,6	5	5,3	
12 B-1	M 127 ML ¹⁾	3/4"	19,05	19,1	29,1	6,2	15,9	35,3	54,7	7,4	-	28,0	1,8	5	5,5	
16 B-1	M 1611 ML	1"	25,4	24,6	36,6	8,2	25,9	57,8	89,7	10,4	-	36,2	3,0	6	8,2	
Shape 103.1 and 103.2																
08 B-1	L 85 ML ¹⁾	1/2"	12,7	17,0	23,0	4,2	11,6	25,5	39,4	5,4	12,7	23,6	1,5	4	5,2	
10 B-1	M 106 ML ¹⁾	5/8"	15,875	16,3	25,8	5,2	13,6	30,1	46,6	7,5	15,8	31,0	1,6	5	5,3	
12 B-1	M 127 ML ¹⁾	3/4"	19,05	18,3	29,0	6,2	15,9	35,3	54,7	9,0	19,0	37,2	1,8	5	5,5	
16 B-1	M 1611 ML	1"	25,4	28,45	41,55	8,2	25,9	57,8	89,7	10,35	25,4	47,2	3,0	6	8,2	

¹⁾ also for the corresponding duplex and triplex chains ²⁾ Nominal pitch

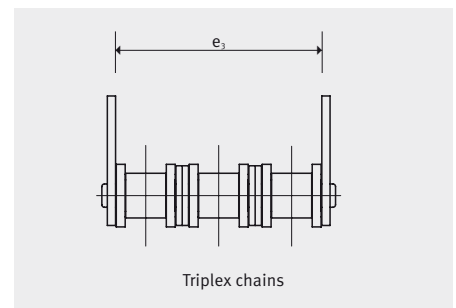
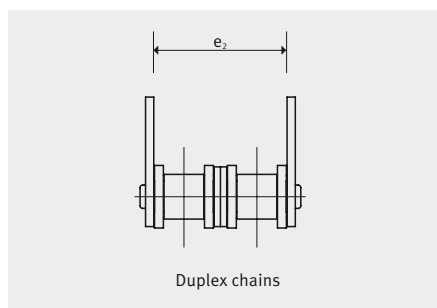
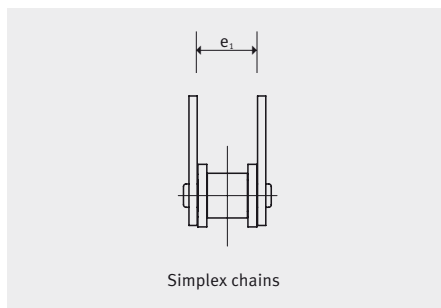

STRAIGHT ATTACHMENTS

The types illustrated are also obtainable for connector and outer links for final assembly and repair.

Fitting attachments on one or both sides, on each outer link or at greater spacing is possible.

Other conveying chains and threaded inserts on request.

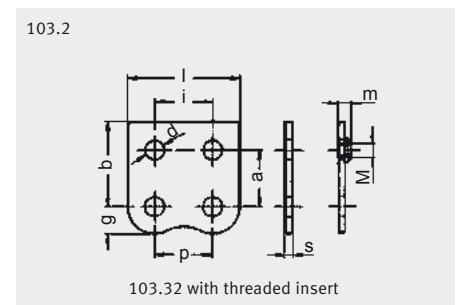
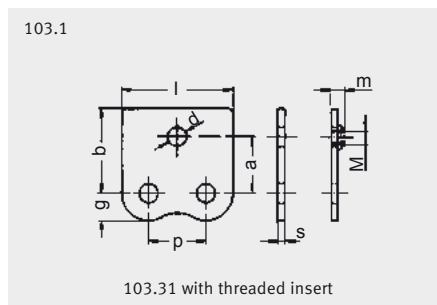
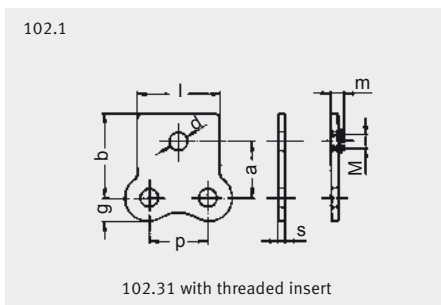

iwis® MEGAlife I conveyor chains with bent attachment plates

based on iwis roller chains complying with DIN 8187

DIN ISO no.	Ref. no. iwis	Pitch ³⁾			Simplex chains			Duplex chains			Triplex chains			Threaded insert				
		p (")	p (mm)	c (mm)	d (mm)	e ₁ (mm)	f ₁ (mm)	e ₂ (mm)	f ₂ (mm)	e ₃ (mm)	f ₃ (mm)	g (mm)	h (mm)	i (mm)	l (mm)	s (mm)	M (mm)	m max. (mm)
Shape 202.1																		
08 B-1	L 85 ML ¹⁾	1/2"	12,7	8,0	4,2	27,6	39,6	41,5	53,5	55,4	67,4	5,4	14,0	-	18,1	1,5	4	5,2
10 B-1	M 106 ML ¹⁾	5/8"	15,875	9,0	5,2	33,6	49,6	50,1	66,1	66,6	82,6	6,8	18,0	-	24,0	1,6	5	5,3
12 B-1	M 127 ML ¹⁾	3/4"	19,05	10,0	6,2	41,1	61,1	60,5	80,5	79,9	99,9	7,4	22,6	-	28,0	1,8	5	5,5
16 B-1	M 1611 ML	1"	25,4	16,0	8,2	53,9	77,9	85,8	109,8	117,7	141,7	10,4	26,0	-	36,2	3,0	6	8,2
Shape 203.1 and 203.2																		
08 B-1	L 85 ML ^{1) 2)}	1/2"	12,7	9,5	4,2	32,6	44,6	46,5	58,5	60,4	72,4	5,4	16,5	12,7	23,6	1,5	4	5,2
10 B-1	M 106 ML ^{1) 2)}	5/8"	15,875	11,0	5,2	30,6	49,6	47,1	66,1	63,6	82,6	7,5	18,0	15,8	31,0	1,6	5	5,3
12 B-1	M 127 ML ^{1) 2)}	3/4"	19,05	12,0	6,2	35,5	56,9	54,9	76,3	74,3	95,7	9,0	20,5	19,0	37,2	1,8	5	5,5
16 B-1	M 1611 ML	1"	25,4	18,0	8,2	57,7	83,9	89,6	115,8	121,5	147,8	10,4	29,0	25,4	47,2	3,0	6	8,2

Conveyor chains D 1611 ML and TR 1611 ML on request ¹⁾ Also for the corresponding duplex and triplex chains ²⁾ Assembly of the bent attachments also possible inward over the chain except when fitted on both sides to D 85 ML, D 106 ML and D 127 ML ³⁾ Nominal pitch

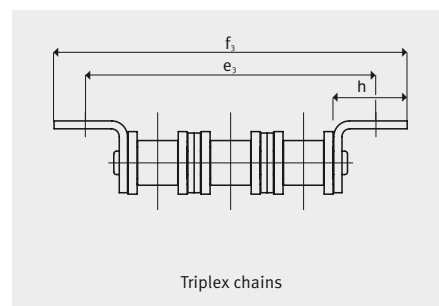
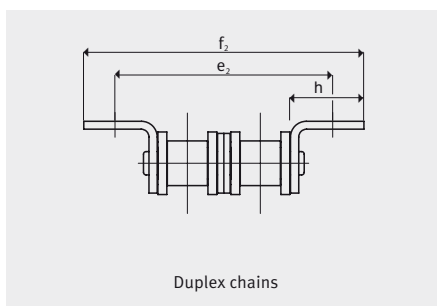
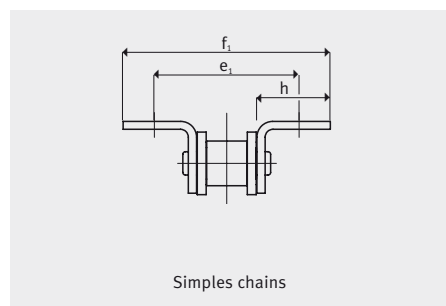

BENT ATTACHMENTS

The types illustrated are also obtainable for connector and outer link for final assembly and repair. Assembly of the bent attach-

ments with threaded insert over the chain facing inwards is not possible. Fitting bent attachments on one or both sides on each

outer link or at greater spacing is possible. Other conveying chains and threaded inserts on request.

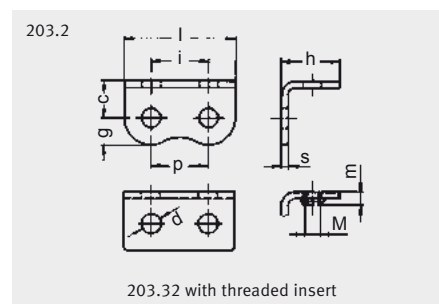
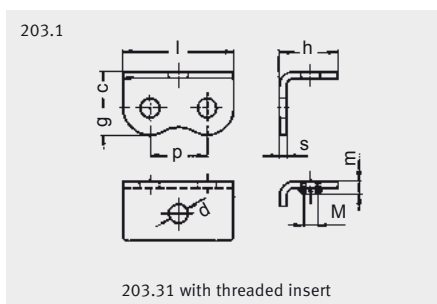
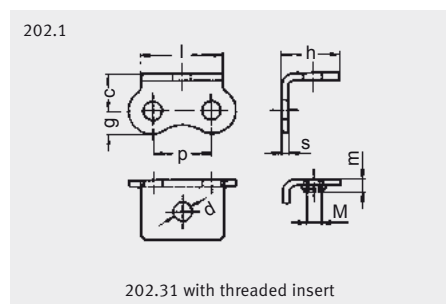

iwis® MEGAlife I conveyor chains with extended pins based on iwis roller chains complying with DIN 8187

DIN/ISO no.	Ref. no. iwis ¹⁾	p (")	Pitch ²⁾		Inner width b ₁ (mm)	Roll diameter d ₁ (mm)	Pin diameter d ₂ (mm)	Design A			Design B and C	
			p (mm)					L ₁ (mm)	l ₁ (mm)	L ₂ (mm)	l ₂ (mm)	l ₃ (mm)
Pin type A, B, C												
08 B-1	L 85 ML ¹⁾	1/2"	12,7		7,75	8,51	4,45	25,5	10,0	40,5	25,0	13,0
10 B-1	M 106 ML ¹⁾	5/8"	15,875		9,65	10,16	5,08	30,0	12,0	48,0	30,0	15,5
12 B-1	M 127 ML ¹⁾	3/4"	19,05		11,75	12,07	5,72	36,0	15,0	51,0	30,0	15,5
16 B-1	M 1611 ML	1"	25,4		17,02	15,88	8,28	53,8	20,0	68,5	35,0	18,0

¹⁾ For multiple chains on request ²⁾ Nominal pitch Other pin lengths and shapes on request

EXTENDED PINS

The types illustrated are also available as connecting links and outer links for final assembly and repair (C only as outer link).

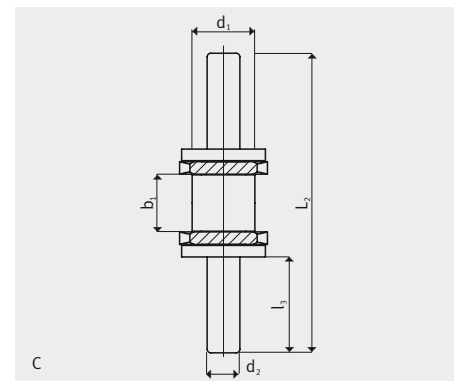
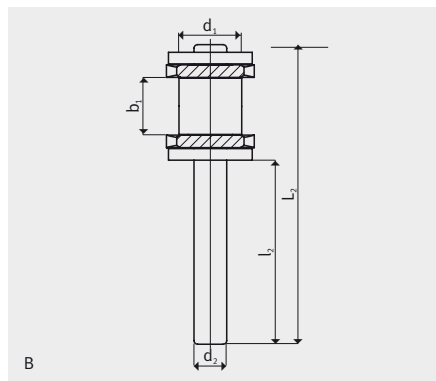
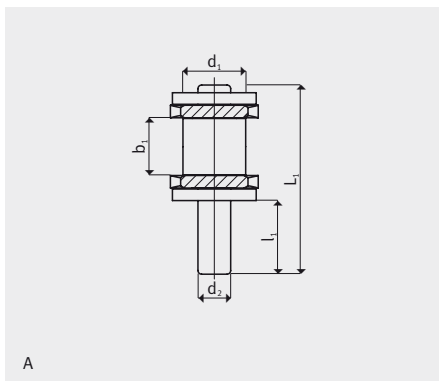

SPECIAL MEGAlife VERSIONS

MEGAlife roller chains are also available in the following special versions:

For example:

- MEGAlife transfer chains with high resistant plastic support brackets or
- maintenance free power and free conveyor chains.

Contact us, our Sales Team will be pleased to advice you.

iwis® MEGAlife II – Roller chains

Complying with DIN 8187-1, ISO 606: 2004

DIN/ISO no.	Ref. no. iwis	Pitch p (")	Pitch p (mm)	iwis (N) med.	Standard (N) min.	Breaking strength F_B	Bearing area F (cm ²)	Weight per m q (kg/m)	b_1 (mm) min.	b_2 (mm) min.	Inner link g (mm) max.	a_1 (mm) max. ¹⁾	Outer link a (mm) max. ¹⁾	Roller d_1 (mm) max.	Pin d_2 (mm) max.	Transverse pitch e (mm)	5 m Versions Article No.
Simplex																	
06 B-1	G 67 ML-2*	3/8"	9,525	11.000	9.000	0,28	0,41	5,72	8,53	8,20	12,90	14,10	6,35	3,31	-	-	50030791
08 B-1	L 85 ML-2	1/2"	12,70	22.000	18.000	0,50	0,70	7,75	11,30	12,20	16,90	18,50	8,51	4,45	-	-	50030461
10 B-1	M 106 ML-2	5/8"	15,875	27.500	22.400	0,67	0,95	9,65	13,28	14,40	19,50	20,90	10,16	5,08	-	-	50030462
12 B-1	M 127 ML-2	3/4"	19,05	34.000	29.000	0,89	1,25	11,75	15,62	16,40	22,70	23,60	12,07	5,72	-	-	50030463
16 B-1	M 1611 ML-2	1"	25,40	75.000	60.000	2,10	2,70	17,02	25,45	21,10	36,10	36,90	15,88	8,28	-	-	50030464
20 B-1	M 2012 ML-2	1 1/4"	31,75	120.000	95.000	5,84	7,36	19,56	29,10	26,60	77,00	79,70	19,05	10,17	36,45	-	50033036
Duplex																	
06 B-2	D 67 ML-2	3/8"	9,525	19.000	16.900	0,56	0,78	5,72	8,53	8,20	23,40	24,60	6,35	3,31	10,24	-	50031074
08 B-2	D 85 ML-2	1/2"	12,70	40.000	32.000	1,00	1,35	7,75	11,30	12,20	30,80	32,40	8,51	4,45	13,92	-	50030465
10 B-2	D 106 ML-2	5/8"	15,875	49.000	44.500	1,34	1,85	9,65	13,28	14,40	36,00	37,50	10,16	5,08	16,59	-	50030466
12 B-2	D 127 ML-2	3/4"	19,05	61.000	57.800	1,78	2,50	11,75	15,62	16,40	42,10	43,00	12,07	5,72	19,46	-	50030467
Triplex – ML-2 roller chains on request																	
Simplex – ANSI roller chains, complying with DIN 8188-1, American standard, ISO 606: 2004																	
08 A-1 ANSI 40	L 85 AML-2	1/2"	12,70	17.500	14.100	0,44	0,60	7,94	11,15	12,00	16,60	17,50	7,95	3,96	-	-	50033770
12 A-1 ANSI 60	M 128 AML-2	3/4"	19,05	41.000	31.800	1,06	1,47	12,70	17,75	18,00	25,30	26,70	11,91	5,96	-	-	50031073
16 A-1 ANSI 80	M 1610 AML-2	1"	25,40	68.000	56.700	1,79	2,57	15,88	22,40	22,80	32,00	33,90	15,88	7,94	-	-	50032667

ML-2 conveyor chains on request

¹⁾ Differing dimensions for cranked links. If cranked links are fitted, it should be noted that the breaking strength of the chain may be reduced by approximately 20%. * straight side plates

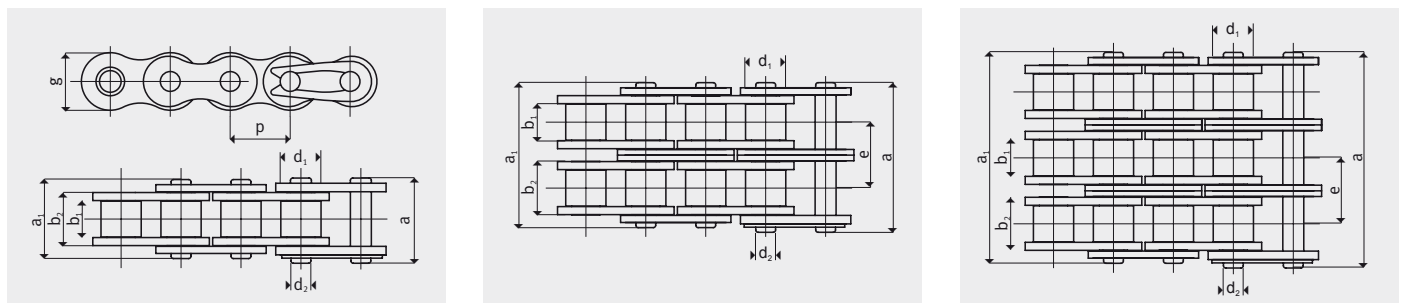

INDIVIDUAL COMPONENTS AND CONNECTING LINKS



Nr. 2 Inner link
Standard designation B

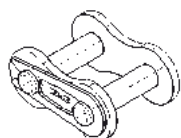

Nr. 3 Connecting link with spring clip
Standard designation E

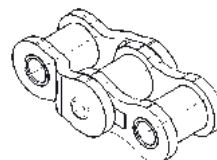

Nr. 7 Double cranked link
Standard designation C

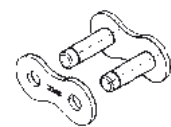

Nr. 8 Outer link
Standard designation A

iwis® MEGAlife conveyor chains

Examples of special chain designs

MEGAlife conveyor chain with straight attachment plates



MEGAlife conveyor chain with extendend pins

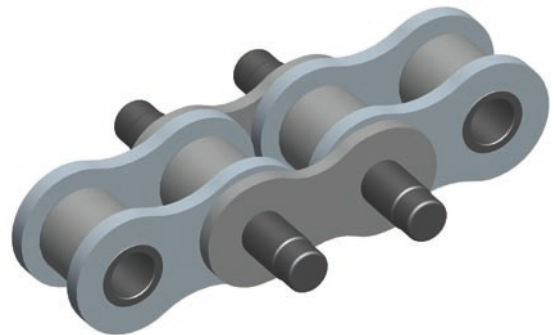

MEGAlife conveyor chain with bent attachment plates

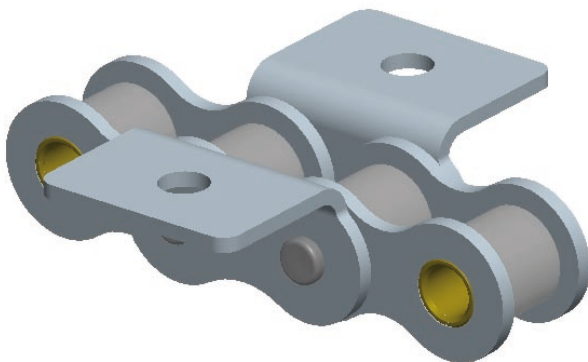

MEGAlife conveyor chain with special attachment plates

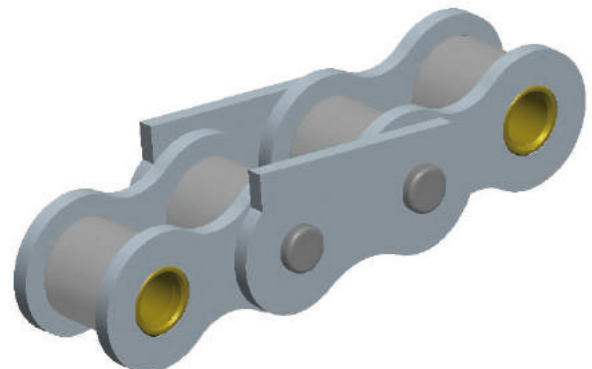

JWIS[®] CR Chains

Jwis corrosion resistant chains consist of hardened, highly alloyed steels showing a good wear resistance and considerably higher fatigue and breaking strengths than for stainless chains. CR chains can be used in those applications where chains despite of extreme conditions need to remain flexible and stainless due to hygienic and visual reasons. A lubrication of CR chains is recommended.





iwis® CR Chains

Corrosion resistant roller chains and conveyor chains

PROBLEM/INITIAL SITUATION

Chains in corrosive media have to possess high fatigue and wear resistance. Chains made of standard steels corrode quickly whilst stainless steels made of V2-A steel do not withstand these stresses. Nickel-plated or galvanised chains only offer limited corrosion-proofing because the coating is destroyed by abrasion.

OUR SOLUTION

iwis high performance chains made of hardened high-alloyed steels with good corrosion resistance and significantly higher strength than stainless steel chains.

HIGHLIGHTS

- high wear resistance if re-lubrication is done at regular intervals
- good and long-lasting corrosion resistance - in comparison with surface-coated chains
- Significantly higher fatigue resistance and breaking strength figures than stainless steel chains
→ smaller dimensions possible

TECHNICAL FEATURES

	iwis CR	iwis Standard	Stainless Chain
All components	hardened	hardened	not hardened
pre-stretched	yes	yes	not regularly
Fatigue strength	80%	100%	50%
Wear resistance	95%	100%	30%

AREAS OF APPLICATION

- In food product processing
- In drinks manufacture
- In packaging machines
- In cheese and dairy technology
- In areas where dominate moist or aggressive conditions
- In cleaning systems
- In (chemical) equipment construction
...and everywhere where chains have to remain articulated despite difficult conditions as a consequence of corrosion and may not rust on hygienic or visual grounds.

CORROSION RESISTANCE

All CR-chains are provided with a reliable high quality initial lubrication.

For permanent corrosion resistance, a sufficient regular re-lubrication is necessary.

DIN ISO no.	Ref. no. iwis	Pitch p (")	a_1 (mm)	Outside width a (mm)	d_1 (mm)	Diameter d_2 (mm)	Plate height	Breaking strength FB	Bearing area f (cm ²)	Weight q (kg/m)
08 B-1	L 85 CR	1/2"	16,9	18,5	8,51	4,45	12,2	15.000	0,50	0,70
10 B-1	M 106 CR	5/8"	19,5	20,9	10,16	5,08	14,4	18.000	0,67	0,95
12 B-1	M 127 CR	3/4"	22,7	23,6	12,07	5,72	16,4	22.000	0,89	1,25

RUST- AND ACID-RESISTANCE

- Dependent on
- duration
 - concentration
 - temperature
 - variations of the mixture of the individual media. We recommend field trials to check fitness for the operational purpose.

CHAIN WHEELS

- Depending on the circumstances, chain wheels can be used which are made of
- stainless material
 - suitable plastics
 - or steel, possibly with an electro-plated coating.

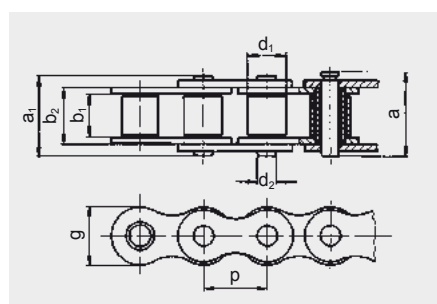

Influencing parameters

Technical outline: Which are the major factors causing corrosion?

THE MAJOR PARAMETERS CAUSING CORROSION

There are four main factors causing corrosion:

- the medium in which the chain moves
- the material the chain is made from
- the construction of the component
- the run time and way of application

CORROSION FACTORS

All CR-chains are provided with a reliable high quality initial lubrication.
 For permanent corrosion resistance, a sufficient regular re-lubrication is necessary.

CONSTRUCTION	MATERIAL	MEDIUM	TIME INFLUENCE
<ul style="list-style-type: none"> • surface condition • other materials in environment • assembly (welding and riveting) • design • protective measures • contact to medium (partial or total dipping) 	<ul style="list-style-type: none"> • steel product • alloying additive • metallurgic condition (heat treatment and mechanical treatment) • pollution • composition 	<ul style="list-style-type: none"> • motion of medium • chemical condition • viscosity • pollution • pH-value (acidity) • temperature • pressure • concentration • solid deposit 	<ul style="list-style-type: none"> • maintenance frequency • re-lubrication intervall • re-lubrication medium • aging of structure • tension development • change of inert layer? • temperature changes

All corrosion factors influence the corrosion resistance to the same extent.
Please refer to our Technical Service Team for professional support.

JWTS[®] Power and free conveyor chains

The new-generation iwis power and free conveyor chains L 88SF and M 120SF combine an optimized load distribution with a more gentle and even transport of the conveyed goods. The synthetic chain guides are capable of carrying up to a double of the weight because the offset roller arrangement on which the chains run reduces the load on the guides by 50 %.

iwis power and free conveyor chains allow easy positioning of the transported material at any point along the transport path and remove the need to start and stop the chain, thereby unsettling the conveyed material. The normal chain speed is 0.1 to 0.5 m/s.

By fitting a simple acceleration rail, the conveying speed can be doubled (at locations in which material is not accumulated) without changing the chain speed. This is often used to separate goods.

Thanks to a special wax lubricant, the chains are low-maintenance. Applied only to the actual links during the assembly of the chains, the conveying rollers – and therefore the conveyed material – remain clean and have no contact with the lubricant. A special-purpose initial lubrication can be used for special-purpose applications. Conveying rollers made from hardened steel or antistatic plastic are available.





iwis® Power and free conveyor chains

PROBLEM/INITIAL SITUATION

- Simple and reliable transport of a very wide range of workpieces and workpiece carriers
- Continuous conveying, accumulating, singling out and acceleration

OUR SOLUTION

- High performance power and free chains in accordance to the high iwis standard in a very wide range of designs.
- L 88 SF and M 120 SF, the exclusive new iwis generation of power and free conveyor chains.

++ EXCLUSIVE ++

- All iwis 3/4" power and free conveyor chains are equipped with **"light running rollers"**.

HIGHLIGHTS

- Gentle transportation and optimum support for the material being conveyed
- In accumulating operation, roller friction only (see figure below)
- The newly developed **"light running rollers"** lead to a high reduction of drive power.
- Please refer to diagram friction force on page 50.

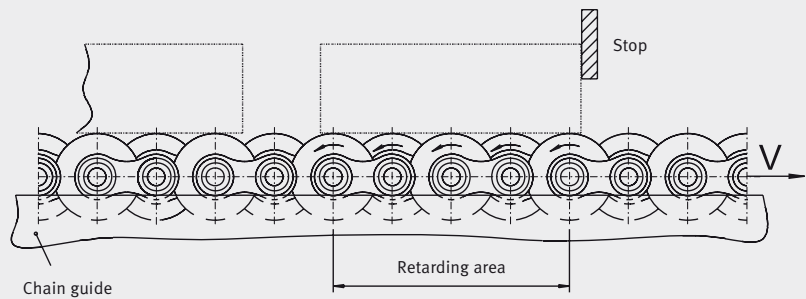
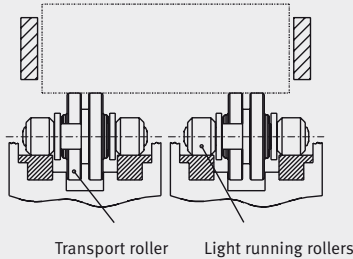

- Positioning the material transported with ease due to simple mounting points
- Chain no longer starts and stops jerkily
- Twice the transport speed is possible due to a simple acceleration rail (see figure below)
- Transport rollers made of either hardened steel or plastic (also antistatic)
- The outside of the chain is clean because only the articulated points are lubricated
- Low-maintenance due to special wax lubrication (standard)
- Other initial lubrication for special applications on request
- Fully compatible with existing guides, deflector units and chain wheels

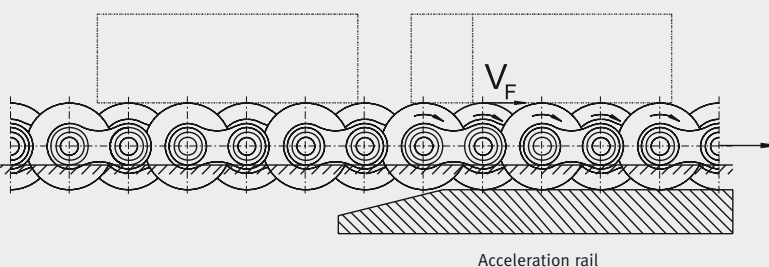

iwis® Power and free conveyor chains

Additional advantages

ADDITIONAL ADVANTAGES OF THE NEW POWER AND FREE CONVEYOR CHAINS L 88 SF AND M 120 SF

- Optimum load distribution – each pin bears load
 → figure ① and ②
- Better support and smoother running of the conveyed material due to the transport rollers having an offset arrangement
 → figures ③ and ④

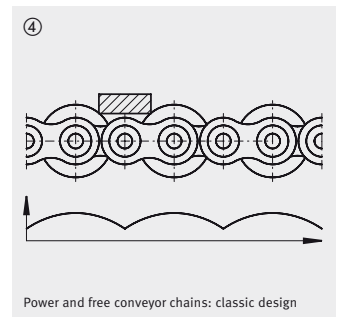
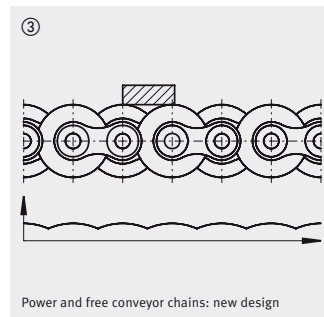
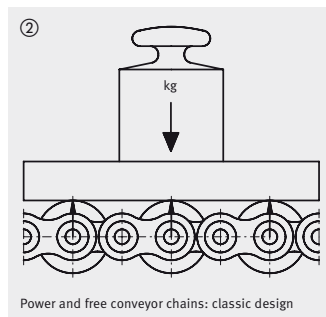
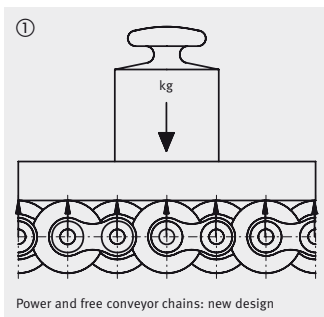

Dimensions - new power and free chains

Ref. no. iwis	Pitch p (mm)	Chain width				Diameter (mm)	Transport roller	
		B (mm)	b (mm)	b _¼ (mm)	e (mm)		Loading capacity per roller (kg)	Weight (kg/m)
L 88 SFK	12,70	27	9,2	14,50	18,70	16,00 ¹⁾	6	0,85
L 88 SFS	12,70	27	9,2	14,50	18,70	16,00	8	1,40
M 120 SFK	19,05	40	11,70	19,55	29,0	24,0 ¹⁾ / 26,0 / 27,0 ¹⁾ / 28,0	10	1,8
M 120 SFK	19,05	45	11,70	19,55	31,5	24,0 / 26,0 / 27,0 / 28,0	10	1,8
M 120 SFS	19,05	40	11,70	19,55	29,0	24,0 ¹⁾ / 26,0 / 27,0 ¹⁾ / 28,0	15	2,8
M 120 SFS	19,05	45	11,70	19,55	31,5	24,0 / 26,0 / 27,0 / 28,0	15	2,8

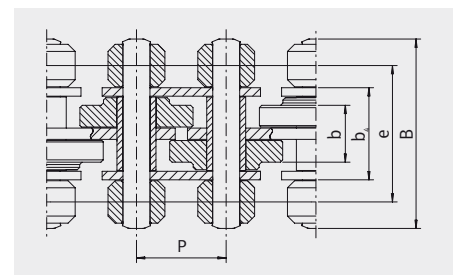

¹⁾ Supplied ex stock

SFK - with plastic transport rollers SFS - with hardened steel transport rollers

iwis® Power and free conveyor chains Side bow power and free conveyor chains

OUR SOLUTION

L 88 SF-SB and M 120 SF-SB design – **the solution** for modular changes of direction in conveyor systems

HIGHLIGHTS

- Extremely small minimum radius for curves 300 mm L 88 SF-SB and 350 mm for M 120 SF-SB

Optimum contact between bush and pin (bearing surface) in curve area (see illustration „our solution“ below)

standard solution

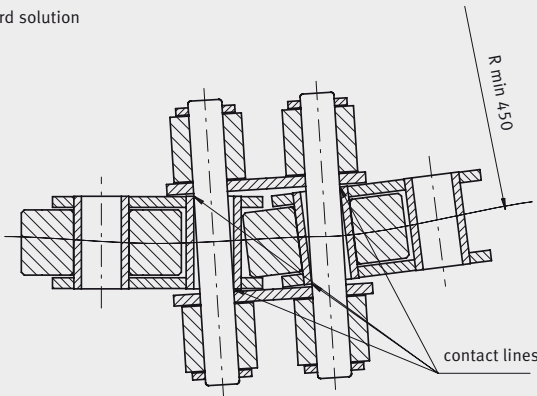

OUR SOLUTION

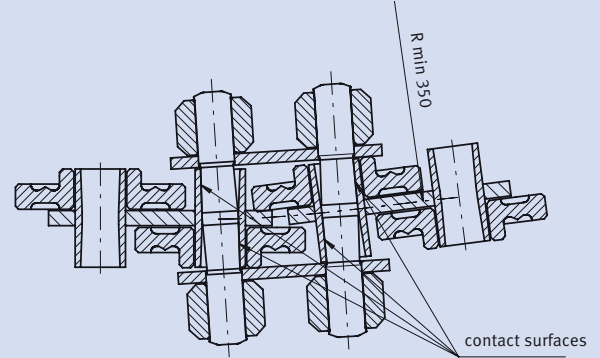

Ref. no. iwis	Pitch p (mm)	Chain width				e (mm)	Transport roller		
		B (mm)	b (mm)	b ₄ (mm)	Diameter D (mm)		Loading capacity per roller (kg)	Weight (kg)	
L 88 SF-SB	12,70	27	9,2	15,0	18,70	16,00	8	1,40	
M 120 SFK-SB	19,05	40	11,70	20,10	29,0	24,0 / 26,0 / 27,0 / 28,0	10	1,8	
M 120 SFS-SB	19,05	40	11,70	20,10	29,0	24,0 / 26,0 / 27,0 / 28,0	15	2,8	

Connecting link dimensions vary

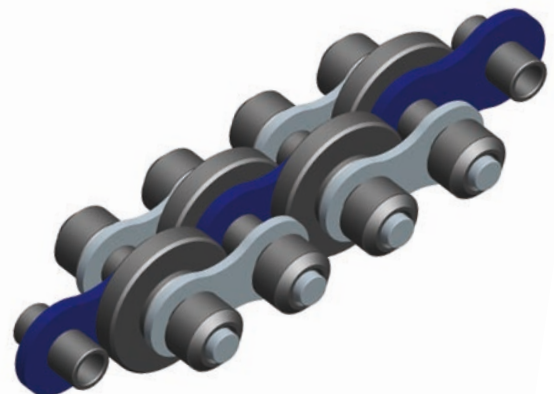
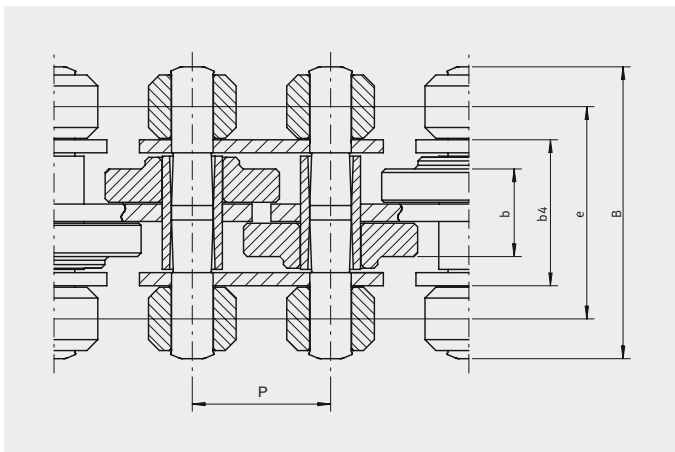

iwis® Power and free conveyor chains

Dimensions - classic power and free conveyor chains (also available devoid of washers)

Ref. no. iwis	Pitch p (mm)	Chain width B (mm)	e (mm)	b ₁ (mm)	b ₂ (mm)	b ₄ (mm)	Width b (mm)	Transport roller		Diameter				
								Diameter	Loading capacity per roller (kg)	Roller d ₁ (mm)	Pin d ₂ (mm)	Weight (kg/m)		
Design OS														
M 127 SFK	19,05	40	27,5	11,75	15,62	19,55	11,0	24,0	26,0	28,0	10	12,07	5,72	1,550
M 127 SFS	19,05	40	27,5	11,75	15,62	19,55	11,0	24,0	26,0	28,0	-	12,07	5,72	2,592
Design M														
M 127 SFK	19,05	40	27,5	11,75	15,62	19,55	11,0	24,0	26,0	28,0	10	12,07	5,72	1,742
M 127 SFK	19,05	43	29,0	11,75	15,62	19,55	11,0	24,0	26,0 ¹⁾	28,0	10	12,07	5,72	1,646
M 127 SFK	19,05	48	31,5	11,75	15,62	19,55	11,0	24,0	26,0	28,0	10	12,07	5,72	1,920
M 127 SFS	19,05	40	27,5	11,75	15,62	19,55	11,0	24,0	26,0	28,0	15	12,07	5,72	2,688
M 127 SFS	19,05	43	29,0	11,75	15,62	19,55	11,0	24,0	26,0	28,0	15	12,07	5,72	2,688
M 127 SFS	19,05	48	31,5	11,75	15,62	19,55	11,0	24,0 ¹⁾	26,0	28,0	15	12,07	5,72	2,880
M 1611 SFK ²⁾	25,4	65	44,9	17,02	25,45	32,0	16,5	38,5	-	-	25	15,88	8,28	4,104
M 1611 SFS ²⁾	25,4	65	44,9	17,02	25,45	32,0	16,5	38,5	-	-	30	15,88	8,28	6,552
Design LR														
LR 165 SFK ²⁾	25,4	30,7	20,0	7,75	11,30	14,65	7,5	24,0	-	-	6	8,52	4,45	0,792
LR 247 SFK	38,1	48	31,5	11,75	15,62	19,55	11,0	24,0	35	-	10	12,07	5,72	1,200
LR 247 SFS	38,1	48	31,5	11,75	15,62	19,55	11,0	24,0	35	-	15	12,07	5,72	2,016
LR 3211 SFK ²⁾	50,8	67,9	44,9	17,02	25,45	32,0	16,5	50,0	38,5	-	25	15,88	8,28	2,764
LR 3211 SFS ²⁾	50,8	67,9	44,9	17,02	25,45	32,0	16,5	50,0	38,5	-	30	15,88	8,28	5,236

¹⁾ Supplied ex stock ²⁾ Chains without light running rollers

SFK - with plastic conveyor rollers SFS - with hardened steel conveyor rollers

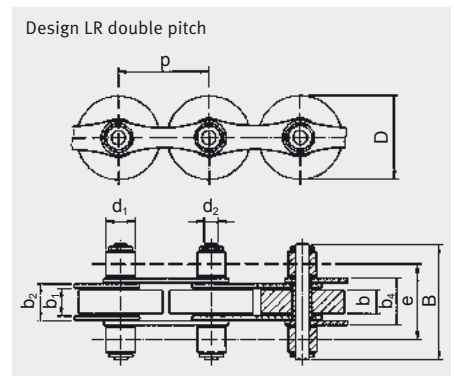
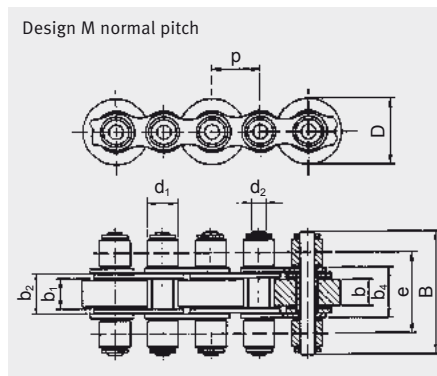
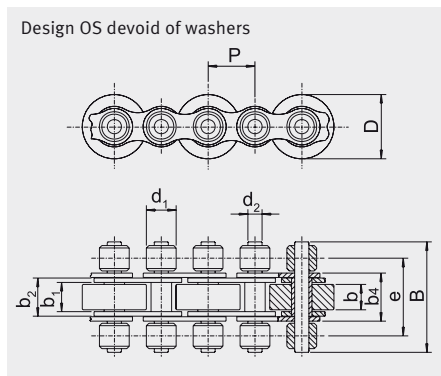
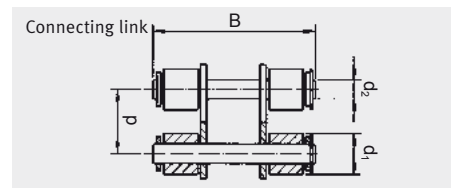

iwis® MEGAlife SFK & SFS – maintenance free iwis power & free conveyor chains

PROBLEM/INITIAL SITUATION

- Lubrication is not at all or only partly possible
- Clean & dry surroundings required
- Difficult/obstructed lubrication passage
- Contamination of installation and material to be conveyed due to chain lubrication

OUR SOLUTION

Maintenance power and free conveyor chain with special redesigned joint and transport rollers made of sintered metal – a technical innovation – **the first genuine maintenance free power and free conveyor chains with light running rollers.**

HIGHLIGHTS

- Excellent wear resistance – also under extreme environmental conditions
- Easy to dismantle
- Reduced overall maintenance cost
- Less production stop and machine downtime
- Environmentally-friendly due to lubrication free chain surface
- Chains suitable for clean rooms

TECHNICAL FEATURES

- Dry chain surface and transport rollers
- Corrosion resistant
- Transport rollers optional as plastic material or steel (stainless steel or nickel-plated)
- Temperature range for use –40 °C up to +160 °C (for transport rollers made of steel)
- iwis MEGAlife power and free conveyor chains are available in the new iwis or classic design in 1/2 inch and 3/4 inch pitch
- Transport rollers made of sintered metal reduce friction. This leads to reduction of driving power and strain on the chain

AREAS OF APPLICATION

- Electronic Industry & Circuit Board Manufacture
- Packaging & Food Industry
- Conveyor-Equipment
- Wood, Glass & Ceramic Industry
- Medical Technology

... and of course in all areas where relubrication is not at all or only partly possible.

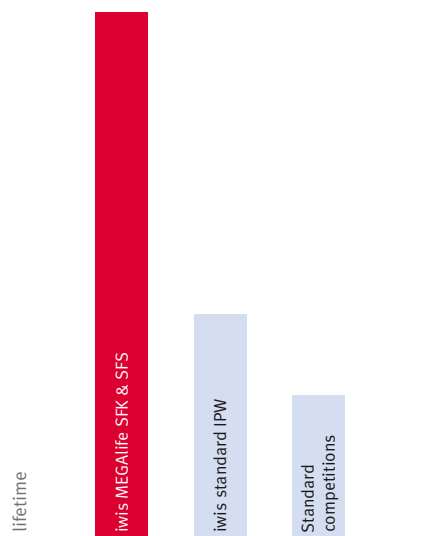

Comparison: lifetime operating time of power and free conveyor chains – without relubrication

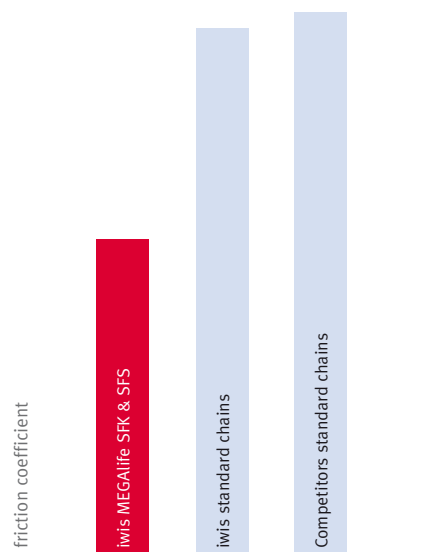

Comparison: coefficient of friction

iwis® MEGAlife SFK & SFS

Dimensions - new power and free conveyor chains

Ref. no. iwis	Pitch p (mm)	Chain width				Transport Roller			
		B (mm)	b (mm)	b _¼ (mm)	e (mm)	Diameter (mm)	Loading capacity per roller (kg)	Weight (kg/m)	
L 88 SFK-ML	12,70	27	9,2	14,50	18,70	16,00	6	0,85	
L 88 SFS-ML	12,70	27	9,2	14,50	18,70	16,00	8	1,40	
M 120 SFK-ML	19,05	40	11,70	19,55	29,0	24,0 / 26,0 / 27,0 / 28,0	10	1,8	
M 120 SFK-ML	19,05	45	11,70	19,55	31,5	24,0 / 26,0 / 27,0 / 28,0	10	1,8	
M 120 SFS-ML	19,05	40	11,70	19,55	29,0	24,0 / 26,0 / 27,0 / 28,0	15	2,8	
M 120 SFS-ML	19,05	45	11,70	19,55	31,5	24,0 / 26,0 / 27,0 / 28,0	15	2,8	

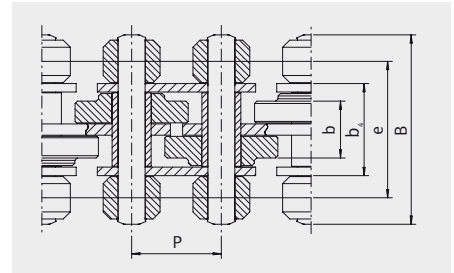

SFK – with plastic conveyor rollers SFS – with hardened steel conveyor rollers

Dimensions - classic power and free conveyor chains

Ref. no. iwis	Pitch p (mm)	Chain width B (mm)	e (mm)	b ₁ (mm)	b ₂ (mm) max.	b _¼ (mm) max.	Width b (mm)	Transport Roller				Diameter				
								Diameter	Tragfähigkeit pro Rolle (kg)	Roller d ₁ (mm)	Pin d ₂ (mm)	weight (kg/m)				
Design OS																
M 127 SFK-ML	19,05	40	27,5	11,75	15,62	19,55	11,0	24,0	26,0	28,0	10	-	12,07	5,72	2,3	
M 127 SFS-ML	19,05	40	27,5	11,75	15,62	19,55	11,0	24,0	26,0	28,0	-	15	12,07	5,72	3,1	
Design M																
M 127 SFK-ML	19,05	40	27,5	11,75	15,62	19,55	11,0	24,0	26,0	28,0	10	-	12,07	5,72	2,3	
M 127 SFK-ML	19,05	43	29,0	11,75	15,62	19,55	11,0	24,0	26,0	28,0	10	-	12,07	5,72	2,3	
M 127 SFK-ML	19,05	48	31,5	11,75	15,62	19,55	11,0	24,0	26,0	28,0	10	-	12,07	5,72	2,3	
M 127 SFS-ML	19,05	40	27,5	11,75	15,62	19,55	11,0	24,0	26,0	28,0	-	15	12,07	5,72	3,1	
M 127 SFS-ML	19,05	43	29,0	11,75	15,62	19,55	11,0	24,0	26,0	28,0	-	15	12,07	5,72	3,1	
M 127 SFS-ML	19,05	48	31,5	11,75	15,62	19,55	11,0	24,0	26,0	28,0	-	15	12,07	5,72	3,1	

Design OS devoid of washers

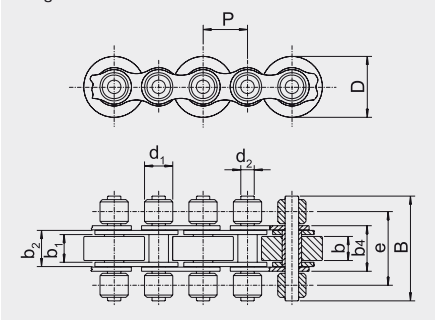

Design M normal pitch

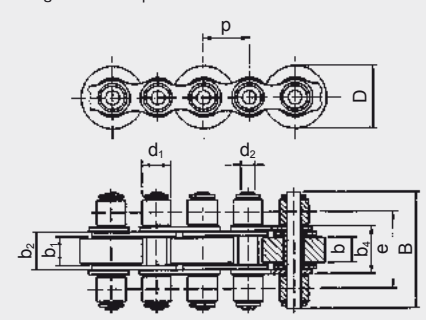

Connecting link

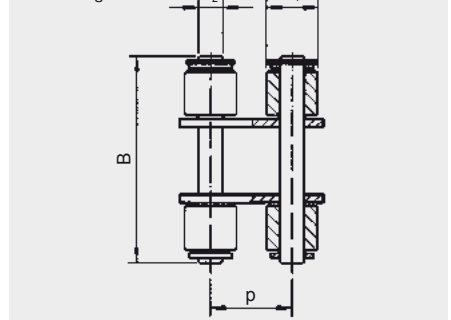

iwis® Power and free conveyor chains Accessories

COMPARISON FRICTION FORCE

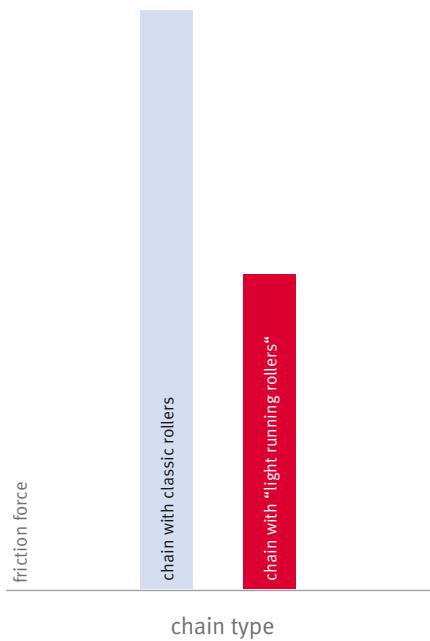

The highly reduced friction force results in a substantial reduction of drive power for the complete unit.

ATTACHMENTS

Guide plates and filler pieces on request.

CHAIN WHEELS

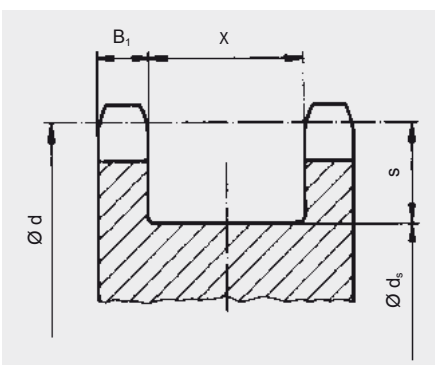

Ref. no. iwis	Pitch p (mm)	B ₁ (mm)	X (mm)	s (mm)
L 88 SF	12,7	4	15,5	10
M 120 SF-B40	19,05	8,3	20,7	15,0
M 127 SF-B40/B43	19,05	8,3	20,7	15,0
M 120 SF-B45	19,05	10,8	20,7	15,0
M 127 SF-B48	19,05	10,8	20,7	15,0
M 1611 SF	25,4	11,6	33,3	20,5

$d_s = d - 2s$ $d = p : (\sin 180^\circ : z)$ Recommended number of teeth minimum $z = 15$

iwis® Power and free conveyor chains Accessories

CHAIN GUIDE/EXAMPLE

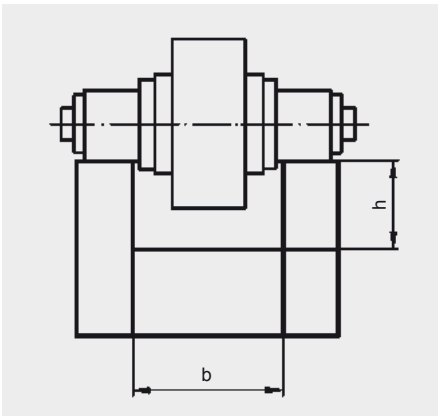

iwis chain	b (mm)	h (mm)
L 88 SF	15	10
L 88 SF SB	15,5	10
M 120 SF	20	15
M 120 SF SB	21	15
M 127 SF	20	15
M 1611 SF	33	20

TOOL

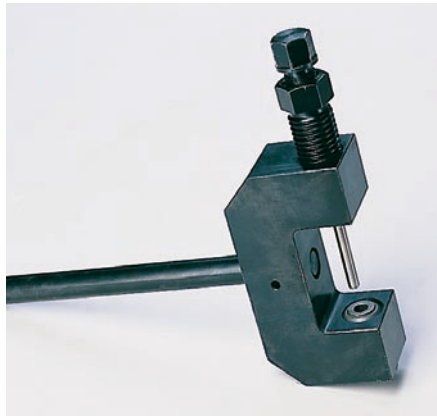

Tool for dismantling power and free conveyor chain M 120 SF and M 127 SF with 3/4 inch pitch

CLEANING BRUSH FOR PROFILES

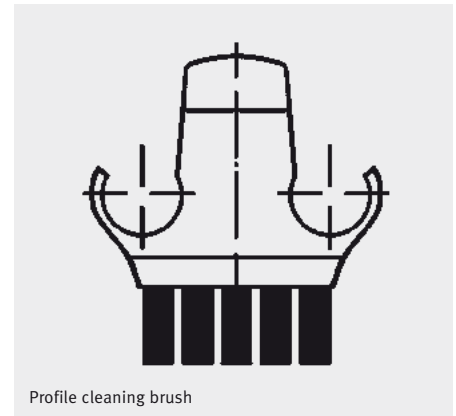

Multipurpose brush especially designed to clean conveying profile for most stringent conditions (for example: chips, welding drops, dust etc.). Brush only available for the new power and free conveyor chain generation of M 120 SF.

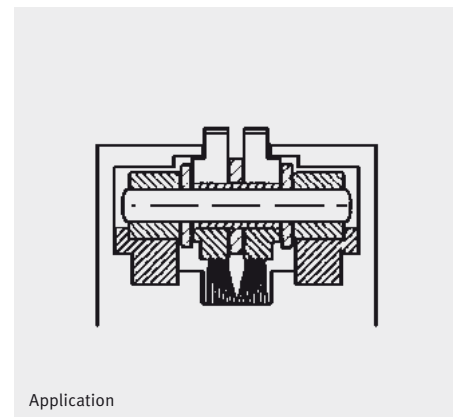

Application

iwis® Power and free conveyor chains

MAINTENANCE GUIDE FOR POWER AND FREE CONVEYOR CHAINS

As for every roller chain, the „bearing points“ of the power and free chain are also subject to natural wear. The correct tension, good guidance and effective relubrication are needed to reduce this and therefore increase the service life of the chain.

A power and free conveyor chain works perfectly at up to 2% extension caused by wear with the provision that it is constantly retensioned. Approximately 5% of the actual chain tensioning force occurring can be used as a guide value for pretensioning.

Power and free conveyor chains are given extremely effective initial lubrication in the works. The lubricant is used up in the course of time and effective and regular relubrication is necessary. During this process, care must be taken that the lubrication is undertaken at the correct points (= bearing points) and that the lubricant is able to creep.

INFORMATION ON THE DESIGN OF POWER AND FREE CONVEYOR CHAINS

Important criteria when selecting a power and free chain are:

- Loading on the transport rollers from the weight of the material being conveyed on them. The load-bearing strength per roller is stated in the tables. If the contact surface for the material being conveyed is uneven, it is necessary to estimate how many free rollers are actually load-bearing.
- Loading on the chain from tensile forces occurring in operation. The most important influencing dimensions are the weight of the material conveyed and the friction factors. The following tensile forces occur in power and free chains:
 - from friction resistance between roller and chain pin
 - from friction resistance between transport rollers and chain bush when in accumulating operation
 - from roller resistance when rolling the runners on to the chain guides and when rolling the conveyed materials on to the transport rollers.

Rough determination of the chain tensioning force F per chain strand:

$$F = \frac{\mu \cdot 9,81 \cdot Q \cdot 1,4}{n} \text{ [N]}$$

μ = friction value 0.08-0.3 depending on:

- material pairing
Steel/steel or plastic/steel
- Condition of the friction surfaces:
dry or lubricated
- Degree of contamination of the friction surfaces

Q = Total weight conveyed [kg]

n = Number of chain strands

The formula is valid for even distribution of the weight loading over the chain strands. If the conveyed material is not in full contact because of unevenness, an estimate has to be made as to what percentage of the length in contact is actually effective. The tensile strength per chain strand is correspondingly higher.

MAX. CONVEYOR LENGTH

Depending on loading 25–30 m, parallel and exact guidance must be ensured.

AREA OF USE...

... of power and free conveyor chains:

- In many areas of conveyor engineering
- Where there are links in processing and assembly lines
- In warehouse engineering
- In a wide range of material flow systems

... and everywhere where work-pieces, components for storage, pallets, containers, crates etc. have to be conveyed, accumulated, accelerated and singled out in a simple way.

Notes

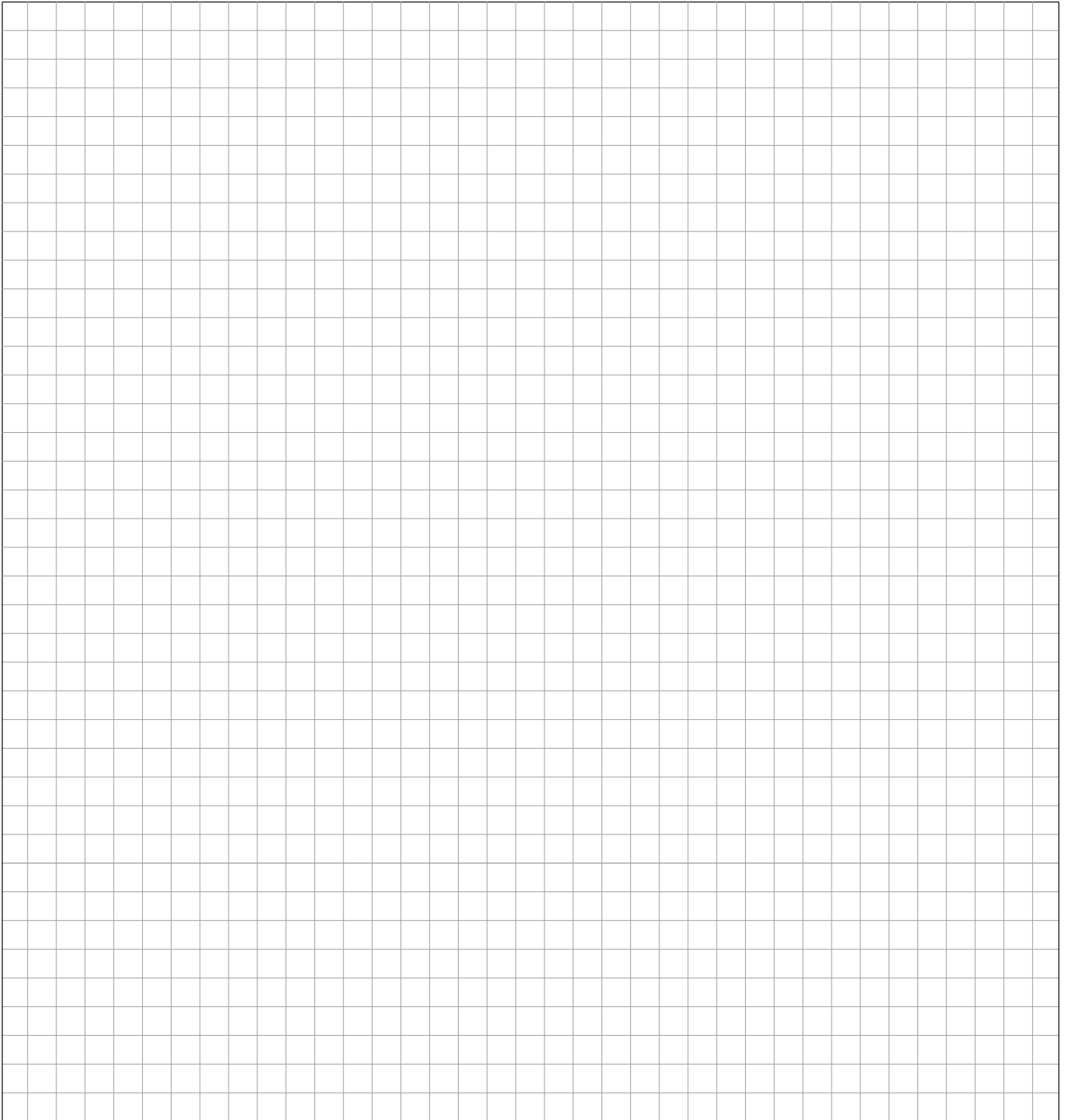



JWTS® Special conveyor chains

iwis offers an extensive program of special chains for various industrial applications and requirements. While the plate chain is being used wherever smooth and reliable conveying through very narrow bends is necessary, the transfer chains are utilized wherever gentle transportation is required. iwis grip chains are applied wherever plate and sheet type materials are drawn in or off, transported or positioned. Additional iwis special conveyor chains: tube and can transport chains, pallet transporting chains, side bow chains, leaf chains anti back bend chains and hollow pin chains.



iwis® Plate chains

PROBLEM/INITIAL SITUATION

Secure and smooth transportation and storage of workpieces and workpiece carriers using very narrow curved track.

OUR SOLUTION

iwis high performance roller chain 3/4 x 7/16" according to DIN 8187 with special plates pressed in precision in full contact (see sketch below).

HIGHLIGHTS

- Plates pressed directly on to chain pins guarantee an absolutely flat transport track with no steps
- Optimum seal for the functioning areas of the chain
- Smooth contact area for workpieces due to engaging form of plates
- Extremely narrow radii of curvature are possible via specially designed plate shape
- Long conveying distances in most close-quartered space possible
- No risk of injury
- Use of DIN chain wheels

AREAS OF APPLICATION

- Conveyor Technology
- General Engineering
- Packaging and Food Industry
- Medical Technology and Pharmaceutical industry
- Linking machines and automation
- Storage and buffer systems

...and everywhere where smooth and reliable conveying through very narrow bends is necessary.

DIN/ISO No.	Ref. no. iwis	P (mm)	s (mm)	A (mm)	B (mm)	R min. (mm)	z min.
12 B-1	M 127 Vers. 1	19,05	3,5	45	50	60	20
12 B-1	M 127 Vers. 2	19,05	3,5	59	80	150	30
16 B-1	M 1611	25,04	3,5	69,5	80	180	22

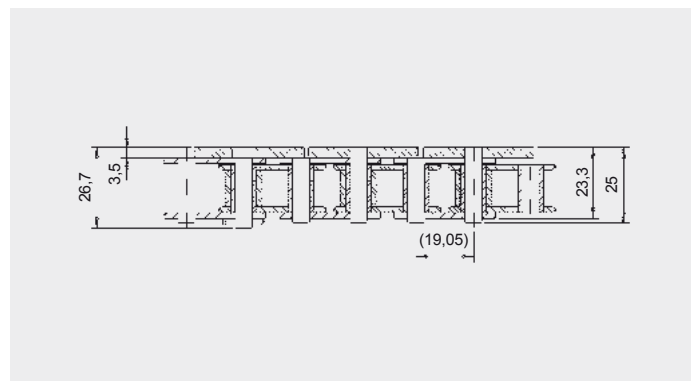
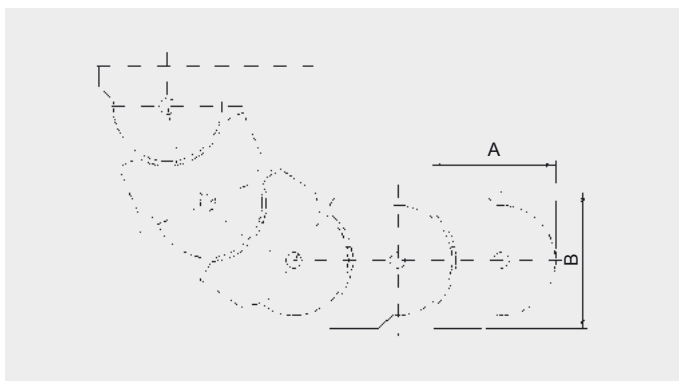

iwis® Transfer chains

Conveying, transporting, stop-start conveying of single parts, pallets...

PROBLEM/INITIAL SITUATION

Open transport chains:

- Prone to interference from foreign bodies and small parts
- Often cause operational breakdowns
- Increased risk of injury
- Damage to material being conveyed
- Adherence of dirt and dust

OUR SOLUTION

The TF chains: iwis high performance roller chains with wear-resistant highly resistant plastic support brackets.

Exclusive to iwis.

HIGHLIGHTS

- Functional areas of the chain are completely sealed, basic chain protected from penetration by foreign bodies
- Gentle transportation when free sensitive materials
- Precisely fitting cover prevents the risk of injury and operational breakdowns
- Chain is completely clean on the outside, therefore no dust is bonded to it.
- Initial lubrication with extremely high adhesion to the base chain, as standard

TECHNICAL FEATURES

- Supporting bracket: made of polyacetal resin
- Temperature range: 40°C to 100°C, up to 140°C for brief periods
- High wear resistance if the material being conveyed has a smooth surface
- Good chemical resistance
- Shore hardness to DIN 53505: 85
- Antistatic on request

AREA OF APPLICATION

- General engineering
- Transport and storage technology
- Packaging and food industry
- Electronics and printed circuit board industry
- Electrical and household equipment
- Medical technology and pharmaceutical industry
- Wood, glass and ceramics processing
- Chemical and process technology
- Printing and paper

...and everywhere where gentle transportation is required.

DIN ISO no. Chain	Ref. no. iwis	Pitch p (mm)	Breaking strength iwis F_b (N)	Permissible weight load per chain strand (N)	Weight (kg/m)	Width B (mm)	Height H (mm)	h (mm)	max. Belastung pro Kunststoffbügel (N)
08 B-1	L 85 TF	12,7	22.000	6250	0,82	19,8	15,2	8,0	12
10 B-1	M 106 TF	15,875	27.500	8000	1,18	24,8	17,5	9,5	26
12 B-1	M 127 TF	19,05	34.000	9750	1,59	29,8	19,8	11,0	43

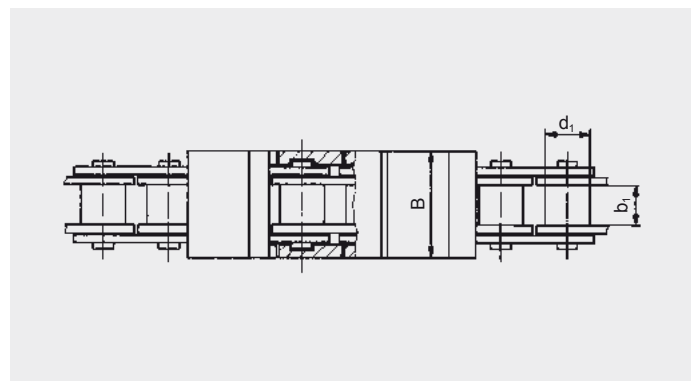
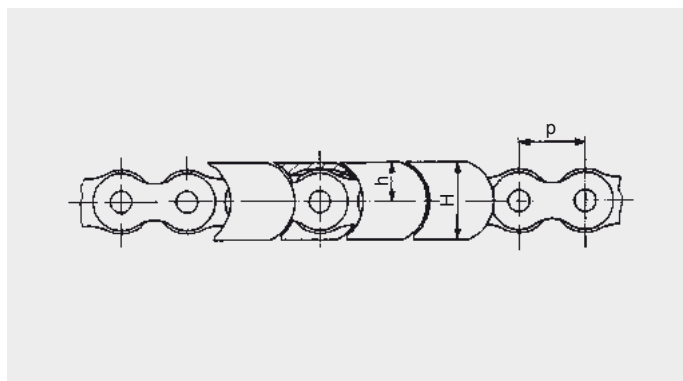

iwis® Transfer chains

Conveying, transporting, stop-start conveying of single parts, pallets...

CHAIN WHEELS

- For TF-chains standard sprockets for chains according to DIN 8187 can be used
- By using chain wheels with number of teeth $z > 18$, the chain is completely protected in the deflection zone.

SPECIAL DESIGN OF BASIC CHAIN

- Nickel-plated
- MEGAlife - maintenance-free
- CR-corrosion resistant only L 85 TF + M 106 TF

CONNECTING LINK

The ends of the chain are connected with a pin block ① which has a separate plug-in plate ② pushed on to it. The two supporting brackets ③ can be clipped on over the chain rivets by pushing down the chain in the right way. No locking spring is required. The relevant 2 supporting brackets are black in colour to make it easy to find the connecting link.

VERSIONS INSTALLED

vertical

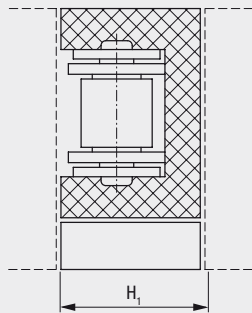

horizontal

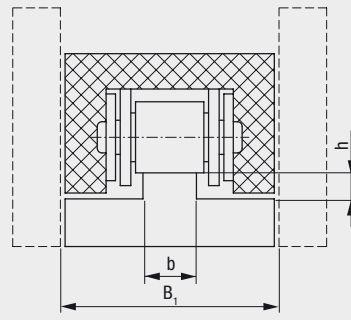

Connecting link

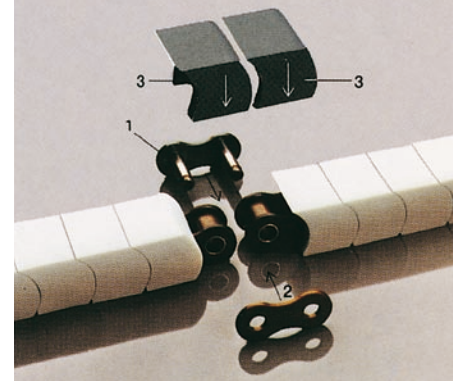

Connecting link: Same dimensions as chain

CHAIN GUIDANCE

Ref. no. iwis	B_1	b	h	H_1
L 85 TF	20	7,5	3,1	15,4
M 106 TF	25	9,5	3,1	17,7
M 127 TF	30	11,3	2,9	20,0

iwis® Grip chains

Gripping, retracting, transporting soft foils

PROBLEM/INITIAL SITUATION

Reliable feeding, transporting and positioning of thin-walled materials with a large area.

OUR SOLUTION

iwis high performance chains with wear- and corrosion-resistant clamping elements
Patent applied for.

HIGHLIGHTS

- Material to be transported is fed through in the best possible way because of the unique swivelling technique of the gripper
- Precise positioning of the material to be conveyed via reliable clamping
- Chain and clamping element with corrosion protection as standard
- Differing levels of spring force allow an extremely wide range of materials to be gripped gently
- Provided with initial lubrication, approved for use in the food industry, as standard

TECHNICAL FEATURES

- Single or double chain 1/2 x 5/16 inch to DIN 8187-1/ ISO 606
- Gripper with 1 or 2 tips, special design on request
- Retaining force is dependent on material conveyed and spring design – differing number of coils and wire spring diameters obtainable
- The gripper opens by running against a control disc (e.g. chain wheel hub) which causes it to swivel out of the way to the outside

AREAS OF APPLICATION

- Packaging industry, especially foil packaging
 - Electronic industry and manufacture of printed circuit boards
 - Feeding in thin-walled sheet, plastics and other hard materials
- ... and everywhere where plate and sheet type materials are drawn in or off, transported or positioned, e.g. for punching, welding, filling, coating, cutting, stretching, shaping, sealing etc.

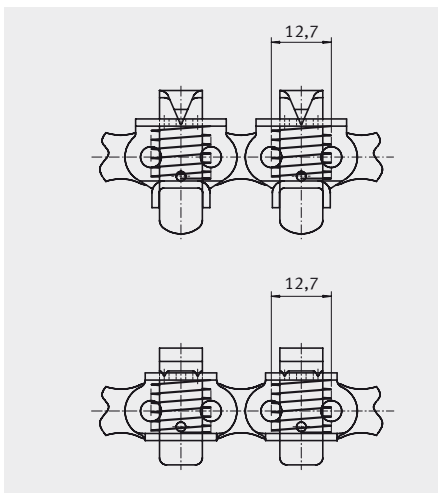

Dimensions x and y dependent on the spring used, on request

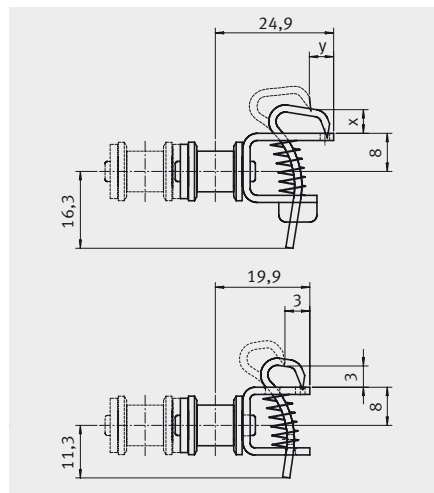

Ref. no. iwis	Pitch P (mm)	Weight q (kg/m)
Simple chain L 85 Grip	12,7	1,15
Double chain D 85 Grip	12,7	1,80

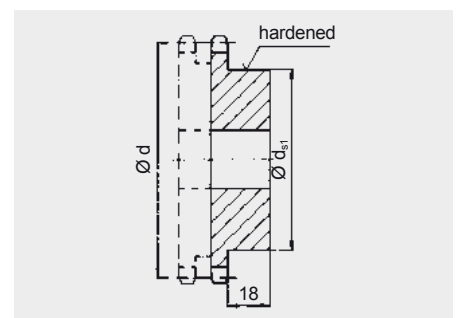

iwis® Grip chains

Gripping, retracting, transporting soft foils

FILM TRANSPORT CHAIN

- special design with button grip elements

Ref. no. iwis	Pitch	Order No.
Simplex chain L 85	12,70	50035491
Simplex chain M 106	15,875	50034301

Dimensions and figures not stated correspond to those for iwis chains M 128 A SL or D 128 A to DIN 8188.

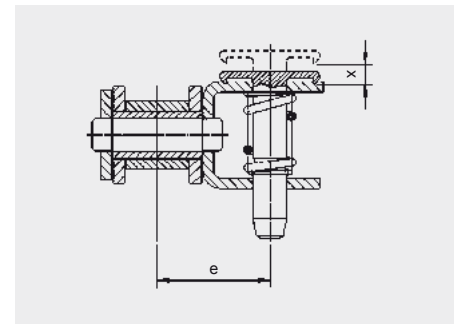
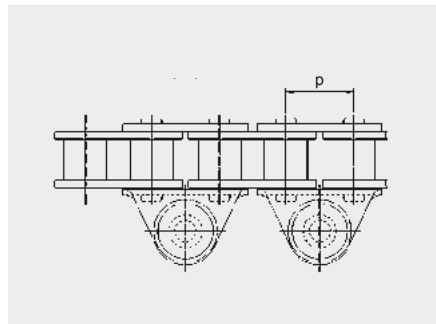
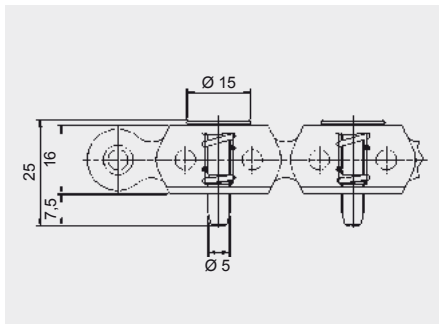

iwis® Pallet transporting chains

HIGHLIGHTS

- Material to be transported can be positioned throughout because of the straight side plates
- Roller chains with straight side plates for transporting a wide range of material

Ref. no. iwis	Pitch p (mm)	g (mm)	Breaking strength F_b iwis mean (N)	Weight q (kg/m)
Single strand chain M 128 AG	19,05	18,0	42.000	1,75
Double strand chain D 128 AG	19,05	18,0	84.000	3,50

Dimensions and figures not stated correspond to those for iwis chains M 128 A SL or D 128 A to DIN 8188.

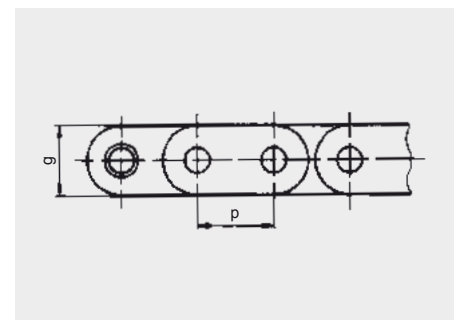
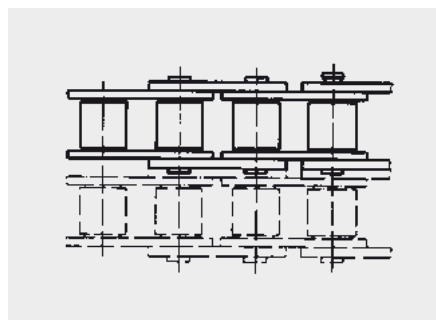

iwis® Side bow chains

Transporting, conveying, pulling on curved shape tracks

PROBLEM/INITIAL SITUATION

- Transporting and conveying on curved shape tracks
- Chains twisting when the shafts are at an angle to each other
- Change in the position of the material being transported e.g. from the horizontal to the vertical

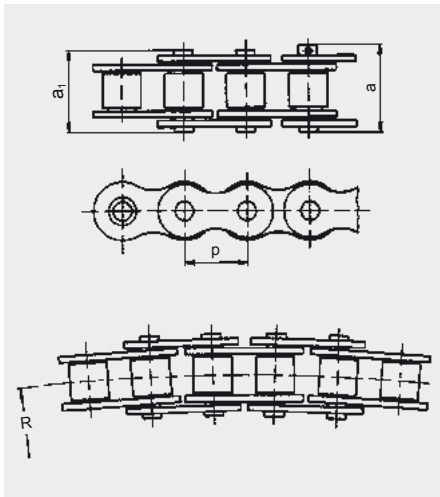

OUR SOLUTION

iwis high performance chains with specially designed chain link.

Exclusive to iwis.

HIGHLIGHTS

- Instead of being in contact with the line, the chain link is in overall contact throughout the curved area.
- Very narrow radii of curvature are possible because of symmetrical, tapered pins
- By using iwis straight and bent side plates suitable for universal use as conveyor chains

Ref. no. iwis	Pitch p (mm)	a ₁ (mm)	Outer width a (mm)	Minimum radius R (mm)	Breaking strength iwis F _B (N)	Continuous (N)	Transient (N)	Weight (kg/m)	Max. permissible chain pull power	Connecting links available
L 85 A-SB	12,7	16,8	17,8	425	10.000	600	1500	0,65		2, 4, 8
M 106 A-SB	15,875	21,0	22,3	500	18.000	900	2500	1,00		2, 4, 8
M 128 A-SB	19,05	26,3	27,7	750	26.000	1200	3700	1,50		2, 4, 8

Dimensions not stated correspond to those for iwis chains to DIN 8188, American standard.

iwis® Anti back bend chains

Chain which is only flexible on one side for pushing lightweight loads and bridging short gaps without guides

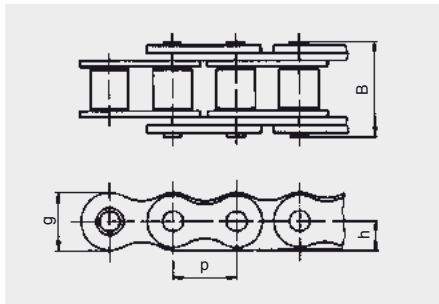

Ref. no. iwis	Pitch p (mm)	g (mm)	h (mm)	B (mm)	Weight (kg/m)
M 128 A SL anti back bend ex.	19,05	18,0	9	30	1,96

The principal dimensions correspond to iwis chain M 128 A SL to DIN 8188
Smallest chain wheel: 10 teeth

iwis® Hollow pin chain

Simple fixing of attachments and transverse struts

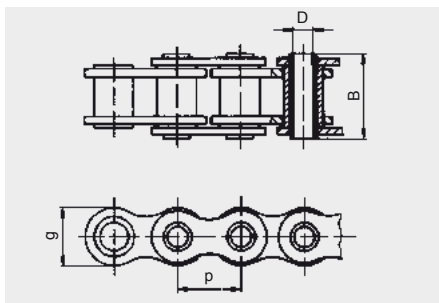

Ref. no. iwis	Pitch p (mm)	g (mm)	B (mm)	D (mm)	Breaking strength iwis (N)	Weight (kg/m)
M 128 HB	19,05	18,0	25,5	6	36.500 ¹⁾	1,23

Special bush chain in accordance with roller chain 3/4 x 1/2 inch to DIN 8188-1
Hollow pins can be arranged at any desired interval.

¹⁾ Breaking strength without pins inserted 34,500 N

iwis® Tube transport chains

PROBLEM/INITIAL SITUATION

Gentle support and reliable transportation for thin-walled hollow bodies through several processing stations (cleaning, painting, drying...)

OUR SOLUTION

iwis high performance chains – roller chains with rust-resistant, easy to change attachments. **Exclusive to iwis.**

HIGHLIGHTS

- Change the transport bars in the system without difficulty using the special iwis tool
- Not necessary to dismantle the chain
- Adapter and bars made of highly alloyed, corrosion-resistant steels with good elastic characteristics
- Long life in comparison to hollow pin chains thanks to the use of the iwis standard roller chain
- Large standard of range of bar lengths
- Different shapes for bar ends - nipples made of aluminium or plastic are also available
- Freely selectable distance between the bars
- 3/4 inch chain also available in curved side design (M 128 ASB)

TECHNICAL FEATURES

- The bars are pinched on to the extended pins of the base chain using an adapter and secured by fins to prevent twisting
- The bar can be changed quickly and easily if a repair is needed by breaching open the adapter with the iwis special tool (see illustration)

AREAS OF APPLICATION

- Everywhere where tubes and other thin-walled hollow bodies (cans) are transported, cleaned, painted, dried...

DIN/ISO no.	Ref. no. iwis	Pitch p (mm)	L max. (mm)	D ₁ (mm)	m (mm)	D ₂ (mm)	D ₃ (mm)
08B-1	L 85 SL	12,7	300	8,0	22,0	4,0	8,0
10B-1	M 106 SL	15,875	300	8,0	22,0	4,0	8,0
12B-1	M 127 SL	19,05	300	8,0	22,0	4,0	8,0
12 A-1 ANSI 60	M 128 ASB	19,05	300	8,0	22,0	4,0	8,0

Please state the length L in any enquiry or order.

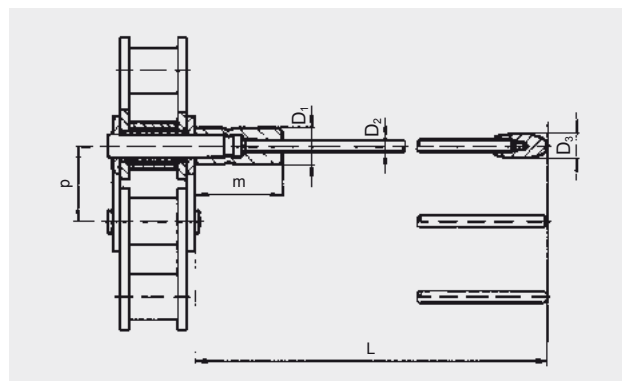
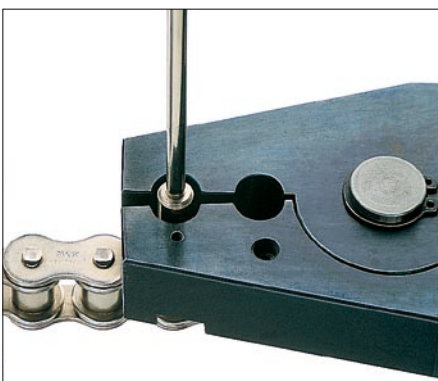

iwis® Can transport chains/Pin oven chains

PROBLEM/INITIAL SITUATION

Safer transport of thin-walled hollow bodies at high speeds and subject to the influences of differing temperatures and media.

OUR SOLUTION

Extremely wear-resistant iwis high performance chains with specially adjusted bars and variable protective heads

HIGHLIGHTS

- Extremely long life and reliable roller chain with integrated hollow pins every seventh pitch
- Simple to change transport bars in the line
- Non-drip high temperature lubricant which evaporates without leaving a residue and is approved for use in the food industry
- Predefined fracturing points in the bars prevent damage within the line if there is a collision

TECHNICAL FEATURES

- The transport bars are inserted in the hollow pins at defined intervals using retaining nuts or split pins
- Precise alignment of the chain wheels and good guidance of the chains increases the length of service life
- The chain should be brushed clean before relubrication at the correct points

AREAS OF APPLICATION

- Everywhere where cans or other thin-walled hollow bodies are transported, painted, dried ...

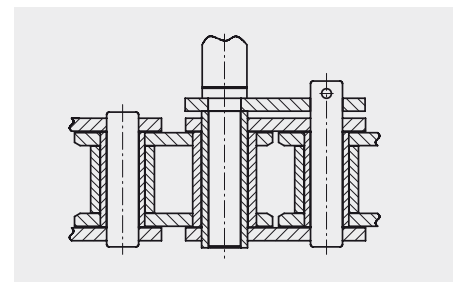
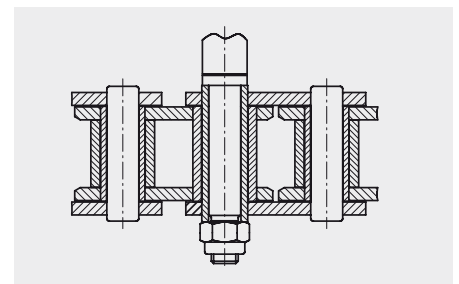
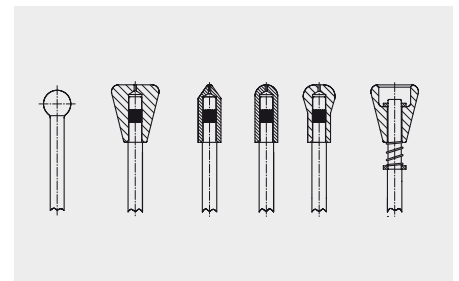

DIN ISO No.	Ref. no. iwis	Pitch p x Inner Width	Breaking Load F_b (N)	Roller d_1 (mm)	Hollow pin Diameter D (mm)	Inner Width b_1 (mm)	Pin Length max. a_1	Weight (kg/m)
12 A-1 ANSI 60	M 128A SL	3/4 x 1/2"	36.500	11,91	6,0	12,7	26,7	1,23

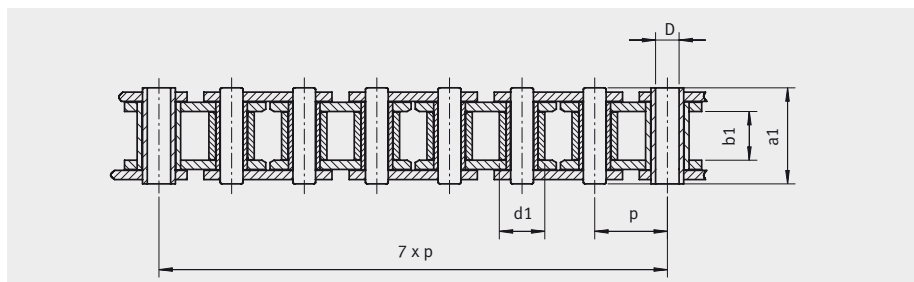

iwis® Leaf chains

Ref. no. iwis	Pitch		Plate combination	Arrangement	Breaking load F_b iwis min (N)	Bearing area f (cm ²)	Weight q (kg/m)	Bearing pin diameter		Overall width		End link dimensions								
	p (°)	p (mm)						d_2 (mm)	a_i (mm)	a (mm)	Plate height g_1 (mm)	Plate thickness s (mm)	d_3 (mm)	d_4 (mm)	g_2 (mm)	g_3 (mm)	u_1 (mm)	u_2 (mm)	u_3 (mm)	u_4 (mm)
Flyerketten																				
FL 522	-	8,0	2 x 2		5.000	0,05	0,15	2,31	5,6	-	6,3	1,0	6,2	-	16,0	-	15,0	10,0	-	-
FL 523	-	8,0	2 x 3		7.000	0,05	0,19	2,31	6,7	-	6,3	1,0	6,2	-	16,0	-	15,0	10,0	-	-
FL 623 ¹⁾	3/8	9,525	2 x 3		10.000	0,08	0,32	3,31	8,3	-	8,1	1,2	6,2	-	16,0	-	15,0	10,0	-	-
FL 623 b ¹⁾	3/8	9,525	2 x 3		20.000	0,20	0,46	3,31	10,9	-	8,2	2,0	6,2	-	-	-	-	-	-	-
FL 823 b	1/2	12,70	2 x 3		28.000	0,18	0,65	4,45	12,4	-	10,8	2,0	8,2	-	18,0	-	20,0	11,0	-	-
FL 834 a	1/2	12,70	3 x 4		21.000	0,17	0,42	3,68	13,1	-	9,1	1,5	8,2	-	18,0	-	20,0	11,0	-	-
FL 834 b	1/2	12,70	3 x 4		42.000	0,27	0,91	4,45	16,5	-	10,8	2,0	8,2	-	18,0	-	20,0	11,0	-	-
FL 845 a	1/2	12,70	4 x 5		34.000	0,24	0,67	3,68	16,9	25	9,1	1,6	8,2	12,2	18,0	25,0	20,0	11,0	30,0	15,0
FL 845 b	1/2	12,70	4 x 5		52.000	0,32	1,00	4,45	19,0	25	10,8	1,8	8,2	12,2	18,0	25,0	20,0	11,0	30,0	15,0
FL 866 a	1/2	12,70	6 x 6		44.000	0,36	0,88	3,68	21,7	28	9,1	1,6	8,2	12,2	18,0	25,0	20,0	11,0	30,0	15,0
FL 866 bd	1/2	12,70	3 x 3 ²⁾		62.000	0,40	1,17	4,45	20,6	28	10,8	1,5	8,2	-	18,0	-	20,0	11,0	-	-
FL 1044 bd	5/8	15,875	2 x 2 ²⁾		57.000	0,37	1,12	5,08	16,8	28	13,7	1,8	10,4	16,2	20,0	35,0	25,0	12,0	45,0	21,0
FL 1066 bd	5/8	15,875	3 x 3 ²⁾		86.000	0,55	1,68	5,08	24,0	35	13,7	1,8	10,4	16,2	20,0	35,0	25,0	12,0	45,0	21,0
FL 1266 bd	3/4	19,05	3 x 3 ²⁾		115.000	0,76	2,18	5,72	30,0	40	14,9	2,2	10,4	16,2	20,0	35,0	25,0	12,0	45,0	21,0
FL 1644 d	1	25,40	2 x 2 ²⁾		157.000	1,00	2,92	8,28	28,0	40	20,8	3,0	12,2	18,2	25,0	40,0	30,0	15,0	50,0	24,0
FL 1666 d	1	25,40	3 x 3 ²⁾		231.000	1,50	4,35	8,28	41,0	50	20,8	3,0	12,2	18,2	25,0	40,0	30,0	15,0	50,0	24,0

¹⁾ Straight side plates ²⁾ double

End link design A

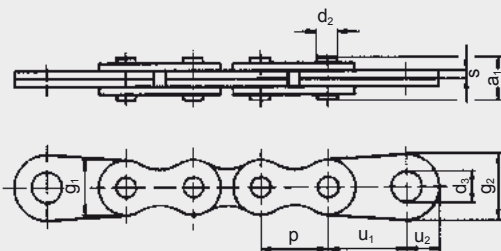

End link design B (from combination 4x4)

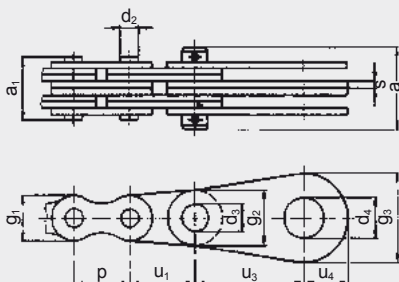

iwis leaf chains are manufactured from precision iwis chain parts to DIN 8187.

The chain selection will be determined by the size and frequency of shock loading and the appropriate national lifting regulations.

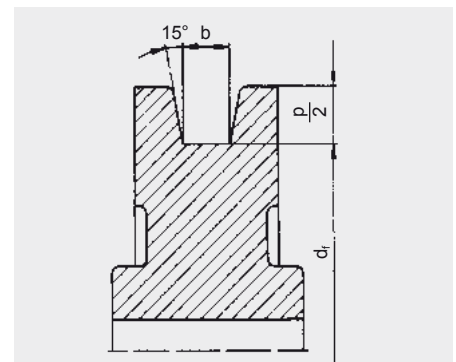

Example for the design of a deflection roller

Inner roller width:
 $b = a_1 \cdot 1,15$
 Minimum base diameter:
 $d_{f \min} = p \cdot 5$

Where possible, fit relatively large diameter



JWIS[®] Sprockets

The form of the Sprockets is determined by the following factors: type of chain, the number of teeth, the torque to be transmitted and the application. A distinction is drawn between sprockets and chain plate wheels for roller chains according to Norm (e.g. DIN 8187/8188) and special versions. Sprockets with hub allow the transmission of a higher torque, whereas plate wheels may be used only for the transmission of small torques. For a detailed instruction regarding design and construction of sprockets and plate wheels, please view of our iwis chain engineering hand book.



iwis® sprockets and plate wheels according to DIN 8187-1, ISO 606: 2004

DIN ISO no. Simplex roller chain Duplex roller chain Triplex roller chain

AVAILABLE SPROCKETS AND PLATE WHEELS

DIN ISO no.	Simplex roller chain	Duplex roller chain	Triplex roller chain
04	•	-	-
05 B	•	•	-
06 B	•	•	•
08 B	•	•	•
10 B	•	•	•
12 B	•	•	•
16 B	•	•	•
20 B	•	•	•
24 B	•	•	•
28 B	•	•	•
32 B	•	•	•

The iwis sprocket and plate wheel program will be supplied either directly from Munich or alternately from our sister company Flexon in Wilnsdorf.

For more detailed information about our complete sprocket program, please take note of the catalogue "Sprockets" of our sister company.



FURTHER AVAILABLE PRODUCTS:

- Taper bush for sprockets
- Chain tensioning wheel complete with ball bearing - ready for installing
- Sprockets for taper bush
- Sliding hub range, series DA
- Sliding hub range, series FT
- Elite sliding clutches, series FT
- Shaft coupling by chain coupling

ON REQUEST WE MANUFACTURE AND DELIVER:

- Special plate wheels according to customer drawings and specifications
- Complete mounted modules existing of chain sprockets, pulleys, bearings and shafts
- Not only prototypes, but also as series produced types in large quantities (project specific)

Attainable materials:

- Case hardened steels (hardened/not hardened)
- Tempering steels (hardened/not hardened)
- Stainless steels
- Plastic

Coating:

- all types possible

Please contact our qualified Technical Service Team for support in chain engineering and the design of chain drives. They will happily assist you.

Chain guides

Examples of plastic chain guides alternatively with steel C-profile

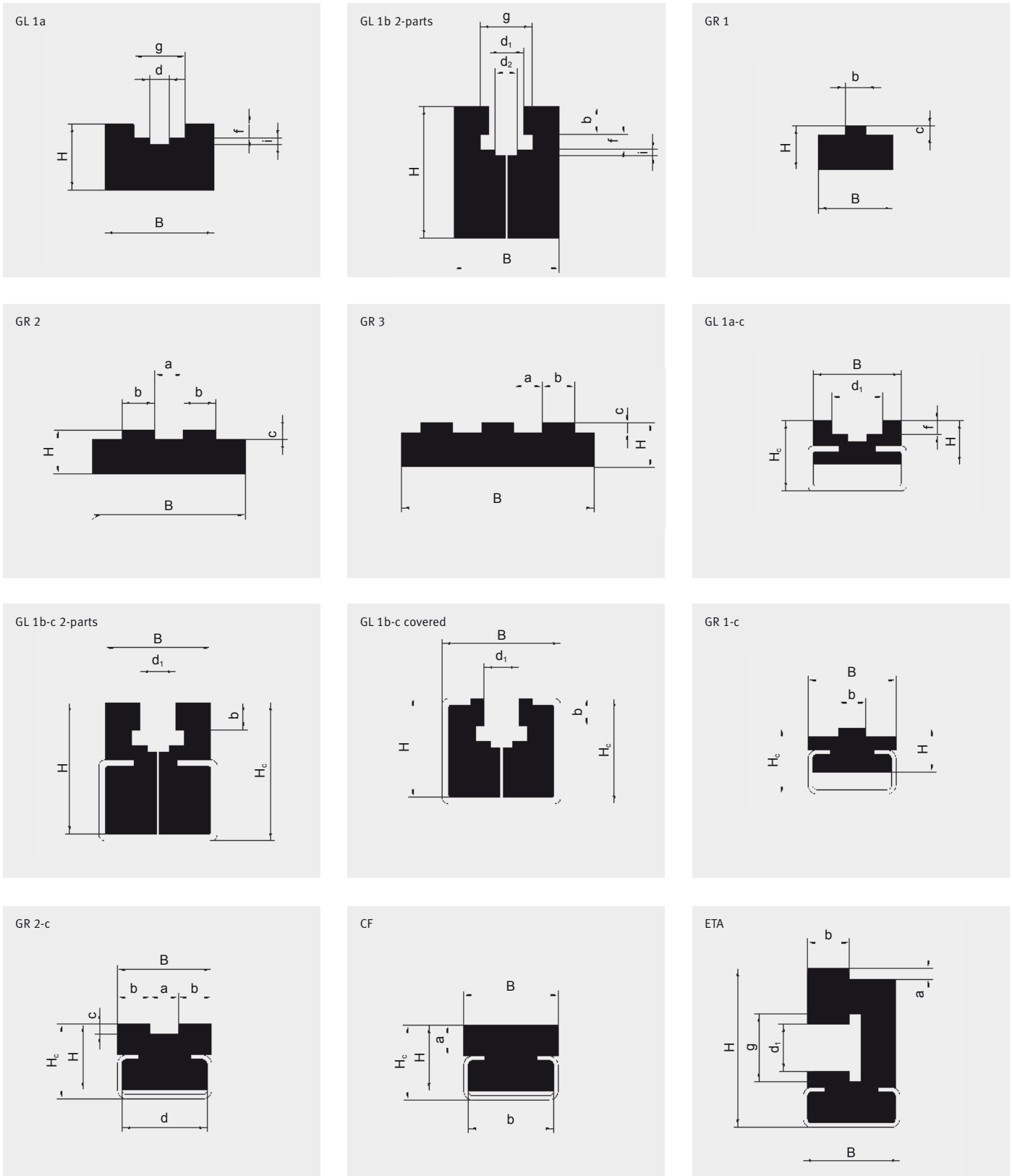

For the complete product range and technical measurements, please check the catalogue "Sprockets" of our sister company Flexon.



JWTS[®] Tools

iwis tools facilitate the breaking and riveting of roller chains pursuant to DIN 8187/8188 and the iwis norm and are useful for workshop use. The iwis tool product range also includes repairing tools for tube and can conveyor chains, power and free conveyor chains and plate chains.



iwis® Tool set for workshop use

The fork and anvil extraction kit is suitable for use with chains manufactured to DIN 8187/8188. Anvil (A) and fork (A 1) are suitable for breaking chains which have shouldered bearing pins.

To break chains with parallel bearing pins it is necessary to use plate (D 1) together with pin punch (B). The tool kits can also be used to assemble chains.

Fetching up punch (C) and bearing pin riveting punch (E) are used to complete this operation.

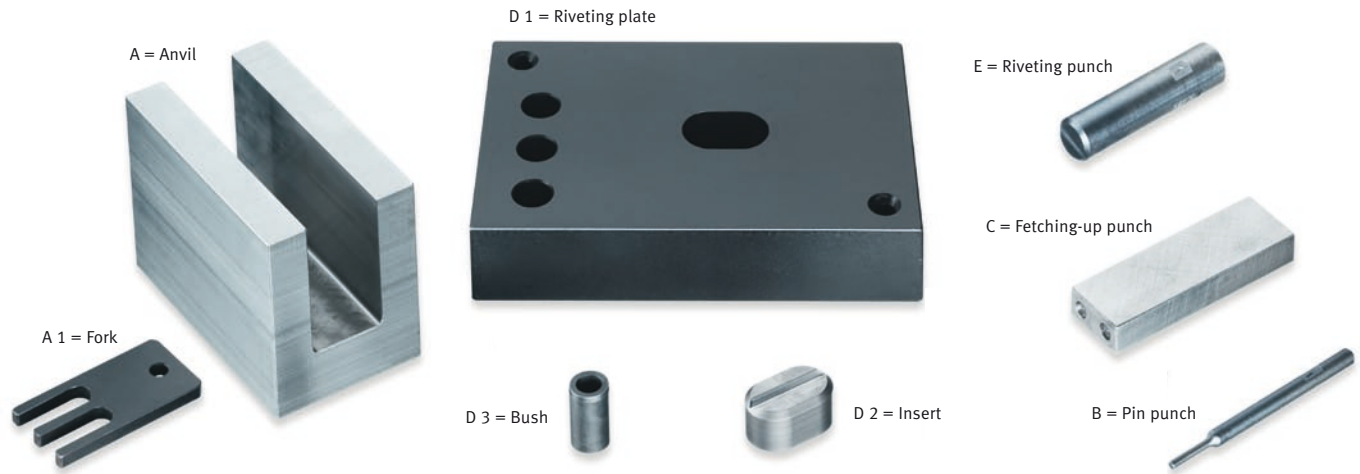

DIN ISO no.	Ref. no. iwis	Pitch (")	Anvil A	Fork A 1	Pin punch B	Fetching-up pun. C	Riveting plate D 1	Insert D 2	Bush D 3	Riveting punch E
Order no.										
05 B	G 52, D 52	8 mm	-	-	5014	40006688	5024	5026	5033	5038
06 B	G 62 1/2, G 67, G 68, EC-6-M	3/8"	-	-	5011	40006689	5024	5026	5033	5038
06 B	D 67, EC-6-D	3/8"	5001	5007	5011	40006689	5024	5026	5033	5038
-	P 83 V	1/2"	-	-	5011	40006692	5024	5026	5033	5038
08 A	S 84 V, L 85 A, D 85 A	1/2"	-	-	5011	40006691	5024	5027	5034	5039
08 B	L 85 SL, D 85 SL, EC-8-M, EC-8-D	1/2"	5000	5004	5012	40006690	5024	5027	-	5039
10 B	M 106 SL, D 106 SL, EC-10-M	5/8"	5000	5005	5013	40006693	5024	5027	-	5039
10 A	M 106 A, D 106 A	5/8"	-	-	5013	40006694	5024	5028	5034	5040
12 B	M 127 SL, D 127, EC-12-M, EC-12-D	3/4"	5000	5006	5013	40006695	5024	5028	-	5040
12 A	M 128 A SL, D 128 A	3/4"	-	-	5016	40006696	5024	5028	5035	5040
16 A	M 1610 A, D 1610 A	1"	-	-	5015	40006705	5024	5029	5035	5041
16 B	M 1611, D 1611, EC-16-M, EC-16-D	1"	5002	5008	5015	40006697	5024	5029	-	5041
20 B	M 2012, D 2012, EC-20-M, EC-20-D	1 1/4"	5003	5009	5015	40006698	5025	5030	-	5042
24 B	M 2416, D 2416, EC-24-M, EC-24-D	1 3/4"	-	-	5017	40006699	5025	5032	5036	5044

Applications

Breaking chains and chain assembly

BREAKING (PARALLEL BEARING PIN)



The outer link to be broken has to be placed over the holes in the riveting plate (D). The bearing pins are hammered flush with the outer plate and then driven through the chain with pin punch (B) whose diameter must be smaller than that of the bearing pin ①. To assist when breaking large pitch chains it is recommended that the rivet head is initially ground away.

BREAKING (SHOULDERED BEARING PIN)



The fork (A 1) is placed through the chain at the outer link which is to be removed. The fork is then supported by the anvil and the bearing pins are driven through the chain using punch (B) ②. Multiple strand chains can also be broken in this way, the fork should then be placed in the top strand of the chain.

ASSEMBLY



The procedure used is common to both shouldered and parallel bearing pin chains. The new riveting link connects the two inner links. This connecting link is supported by an insert in riveting plate (D) ③.



A new outer link plate is fitted using fetching-up punch (C) ④. With parallel bearing pin chain it is possible to over fit the outer link plate on the bearing pins. It is necessary to check that the joint remains free and easily moveable after fitting.



The newly fitted outer link then requires the bearing pin ends to be riveted. This is done with riveting punch (E) ⑤.

iwis® Chain breaker

How to use the iwis multi station chain breaker

CHAIN BREAKER

This multi-station rivet extractor can be clamped in a vice or screwed onto the workbench. Positioning it along the front edge of the bench will provide clearance so that the full range of chains can be cut. Supports to the left and right make chain handling easier when long chains are being inserted.

The rotating head holds five sets of ejector tools. Each set is marked with the pitch of the chain which they cut. The rotating head holds five sets of ejector tools marked with the chain size. The following iwis chains can thus be taken apart at the correct setting.

A distinction is made here between:

- Chains with shouldered pins
- Chains with parallel pins

(look at page 79)

ARTICLE NO. 4500

REPLACING THE PRESSURE PINS AND SUPPORT FORKS

Pressure pins ①:

Loosen grub screws ② pull pins out upwards. Replace as a complete set.

Support forks ③:

Loosen top nut ④ after knocking out safety spring pin. Press out middle bolt ⑤ downwards and remove tool tray ⑥ forward.

Take out the two spring pins which secure the support fork. Insert new fork.

Pay attention when reassembling, that the pressure plate ⑦ is correctly positioned with the latch pin at the back of the body casting. Tighten nut ④ back up and secure with pressure pin.

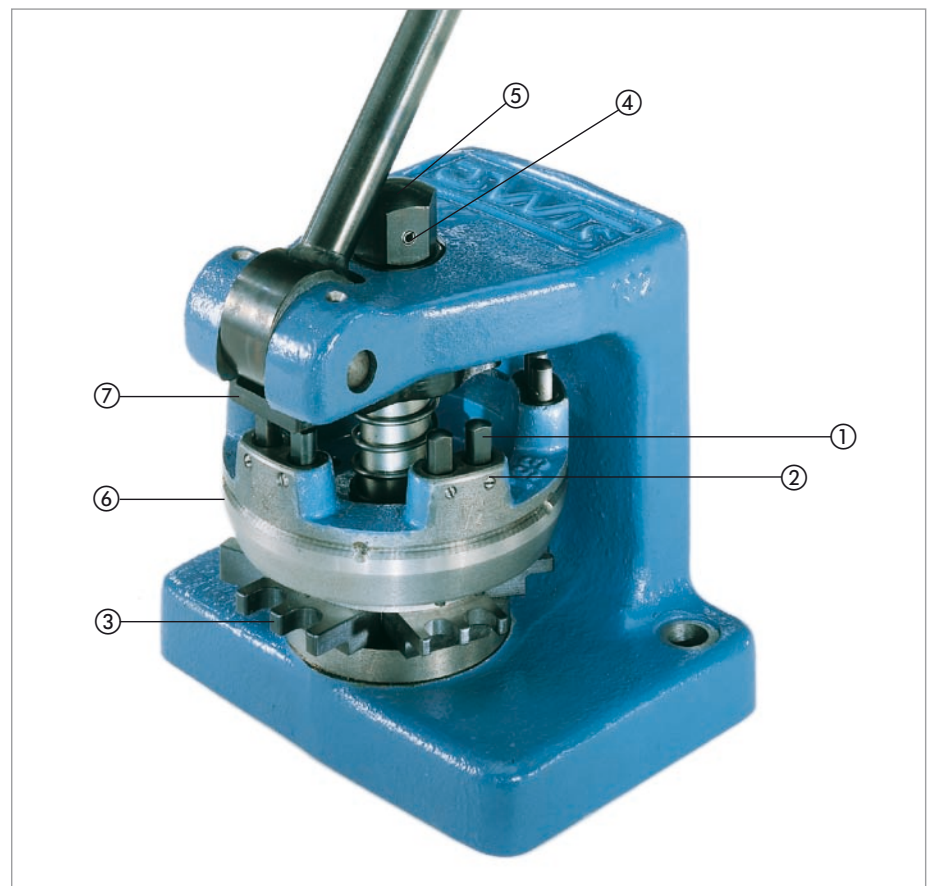

iwis® Chain breaker

How to use the iwis multi-station chain breaker

A) CHAINS WITH SHOULDERED PINS



Chain link with shouldered pin

For breaking chains with shouldered pins the chain is fitted into the appropriate fork according to pitch, and the complete outer link is pressed out when the lever is pulled. It is important that the chain is fully located in the fork.

DIN ISO no.	Ref. no. iwis	Pitch	Adjustment
06 B - 2	D 67	3/8 x 7/32"	3/8"
06 B - 3	Tr 67	3/8 x 7/32"	3/8"
08 B - 1	L 85 SL	1/2 x 5/16"	1/2"
08 B - 2	D 85 SL	1/2 x 5/16"	1/2"
08 B - 3	Tr 85	1/2 x 5/16"	1/2"
10 B - 1	M 106 SL	5/8 x 3/8"	5/8"
10 B - 2	D 106 SL	5/8 x 3/8"	5/8"
10 B - 3	Tr 106	5/8 x 3/8"	5/8"
12 B - 1	M 127 SL	3/4 x 7/16"	3/4"
12 B - 2	D 127	3/4 x 7/16"	3/4"
12 B - 3	Tr 127	3/4 x 7/16"	3/4"

B) CHAINS WITH PARALLEL PINS



Chains with parallel bearing pins

For breaking chains with parallel pins it is necessary to grind off the rivet heads on one side of the chain. Afterwards the outer link is pressed out as above.

DIN ISO no.	ANSI type	Ref. no. iwis	Pitch	Adjustment
06 B - 1	-	G 67	3/8 x 7/32"	3/8"
08 A - 1	ANSI 40	L 85 A	1/2 x 5/16"	1/2"
08 A - 2	ANSI 40-2	D 85 A	1/2 x 5/16"	1/2"
08 A - 3	ANSI 40-3	Tr 85 A	1/2 x 5/16"	1/2"
10 A - 1	ANSI 50	M 106 A	5/8 x 3/8"	5/8"
10 A - 2	ANSI 50-2	D 106 A	5/8 x 3/8"	5/8"
10 A - 3	ANSI 50-3	Tr 106 A	5/8 x 3/8"	5/8"
12 A - 1	ANSI 60	M 128 A SL	3/4 x 1/2"	3/4"
12 A - 2	ANSI 60-2	D 128 A	3/4 x 1/2"	3/4"
12 A - 3	ANSI 60-3	Tr 128 A	3/4 x 1/2"	3/4"

If a grinding device is not available the rivets can be knocked out with a punch after the outer sideplate has been pressed off. Here the bushes must be well supported to prevent them coming off the inner plates

when the pressure pins and support forks are being replaced. Although chains can be taken apart without pregrinding the riveted head the danger of damage to the bush bore does exist. This could reduce chain

life. The iwis multi-station chain breaker can also be used to cut conveyor chains with straight or bent attachments plates of corresponding size. It is not suitable for 3/8 x 5/32" chains.

iwis® Repairing tool for tube and can conveyor chains Replacement of conveyor pins

SPECIAL TOOL

The above represented iwis tool has been specially developed to repair tube and can conveyor chains.

It allows easy replacement of conveyor pins on already installed chains, types L 85 SL, M 106 SL, M 127 SL, M 128 ASL and M 128 A-SB (changeable).

ARTICLE NO. 40000421

Chain	Pitch	D_1	m
L 85 SL	12,7	8,0	22,0
M 106 SL	15,876	8,0	22,0
M 127 SL	19,05	8,0	22,0
M 128 ASL	19,05	10,0	22,0
M 128 A-SB	19,05	10,0	22,0

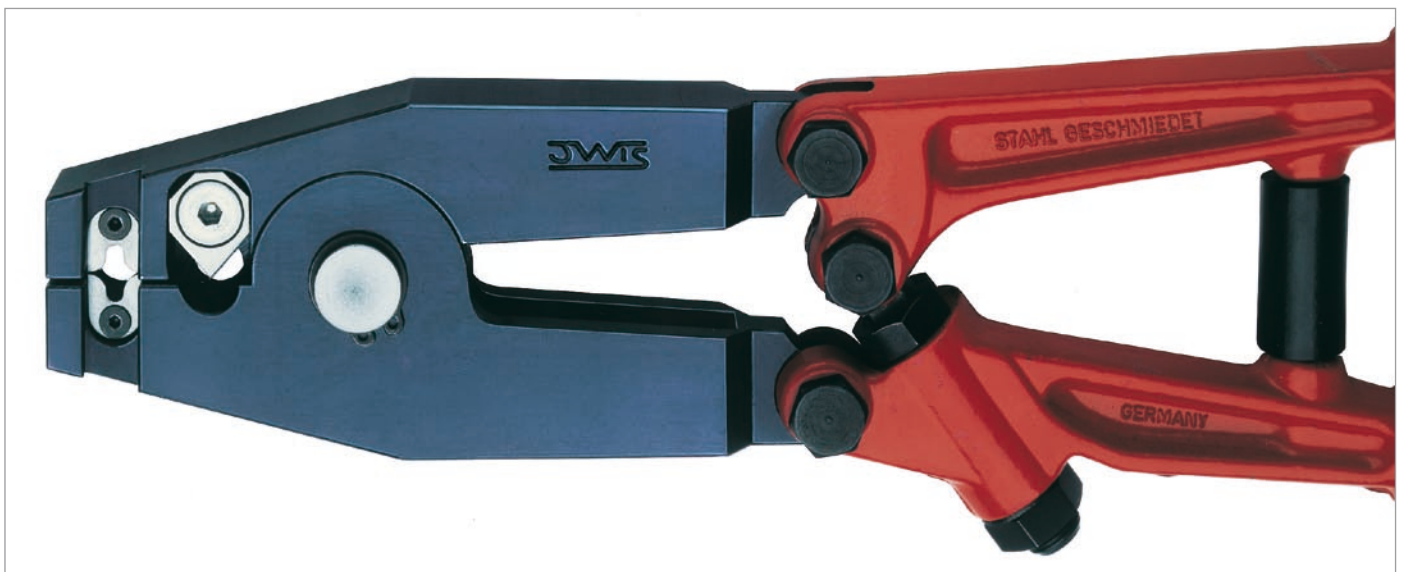
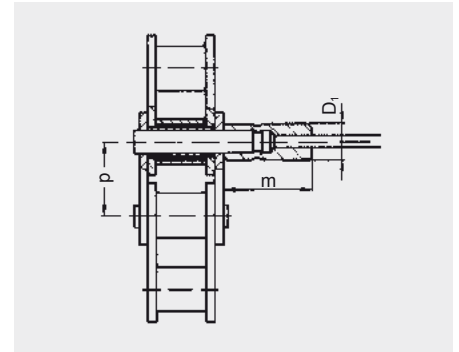

How to employ it

Removal and fastening of pin adapter

REMOVE PIN ADAPTER



Insert the adapter into the jaws ① and break it by closing the tool. If necessary, repeat the action after 45° rotation. Once the adapter has been broken, remove the pin.



FIXING OF A NEW CONVEYOR PIN



The new adapter is set onto the extended pin. Seize it with the gripping jaws ② and clamp it with the tool. Thus repaired, the chain is operational again.



iwis® Chain pin extractor and **iwis**® Chains pullers

UNIVERSAL CHAIN PIN EXTRACTOR H

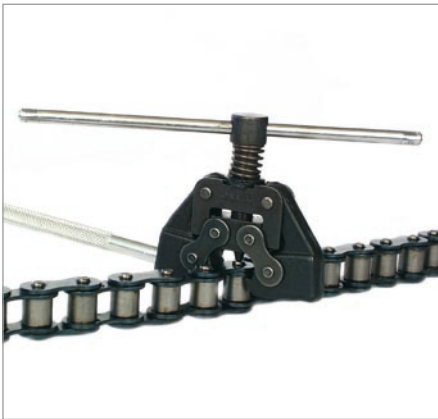

ARTICLE NO. 4511

For use with any chain having shouldered bearing pins only.

Chain range and reference numbers 0.500" to 0.750" pitch:

- L 85 SL
- D 85 SL
- Tr 85
- M 106 SL
- D 106 SL
- Tr 106
- M 127 SL
- D 127
- Tr 127

The chain is clamped between the extractor jaws and the pins are then pressed out one by one by rotating the extractor handle.

SIMPLE RIVET EXTRACTOR F

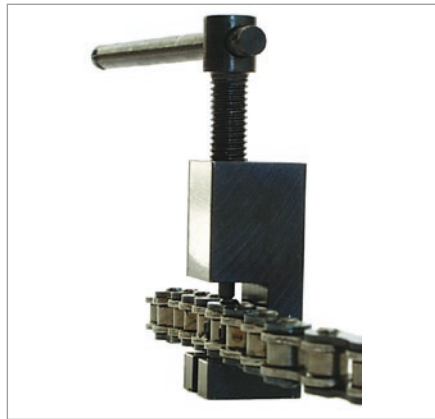

ARTICLE NO. 4516

For chains with parallel pins.

Chain ref:

- P 83 V
- S 84 V

The chain is placed in the tool and the pins are pressed one by one through both outer plates. (Note: This extractor should not be used on chain with shouldered pins).

CHAIN PULLERS



ARTICLE NO. A) 4518 B) 4519

- a) No. 35 for 3/8 to 3/4" pitch chain
- b) No. 80 for 1" pitch chains and bigger

iwis® Tools for breaking and riveting of roller chains

Outline

	no.	Art-No.
Multi-station rivet extractor		4500
Spare parts for iwis multi station rivet extractor		
Pressure plate	7	9806
Spare-part-set fork and 2 punch points for 3/8" incl. spring		11926
Spare-part-set fork and 2 punch points for 1/2" incl. spring		11927
Spare-part-set fork and 2 punch points for 5/8" incl. spring		11928
Spare-part-set fork and 2 punch points for 3/4" incl. spring		11929
Universal rivet extractor		
Universal rivet extractor H for chains of 1/2" to 3/4" pitch		4511
Replacement spindle		4512
Reversible replacement pin		4513
Simple rivet extractors F no.4 for F82V, S84V, L85A		4516
Replacement pin		4517
iwis special tools		
Repairing tool for tube and can conveyor chains		40000421
Tool for breaking power and free conveyor chains		
Insert for assembling/disassembling		40000646
Replacement pin		40001734
Chain disassembly tools for plate chain		40003392
Tensioner for mounting procedure		
No. 35 3/8" to 3/4"		4518
No. 80 from 1" on		4519
Additional articles		
Chain gauge		4568
Chain lubricant VP 6 Kombi superplus 400 ml (packaging unit: 12 pcs.)		15701

CHAIN DIASSEMBLY TOOLS



ARTICLE NO. 40000646

For power and free conveyor chains M 120 SF and M 127 SF with pitch 3/4".

CHAIN DIASSEMBLY TOOLS

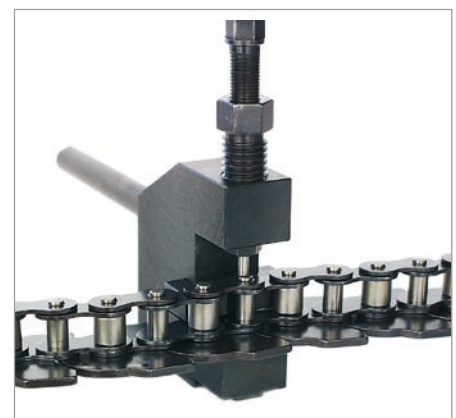

ARTICLE NO. 40003392

For plate chains M 127 with pitch 3/4".

iwis® Tools
Outline

DIN ISO No.	No.	Art-No.
Anvil A		
08 B, 10 B, 12 B	2	5000
06 B	3	5001
16 B	4	5002
20 B	5	5003
Fork A1		
08 B	2	5004
10 B	3	5005
12 B	4	5006
06 B	6	5007
16 B	8	5008
20 B	9	5009
-	10	5010
Pin punch B		
06 B, 08 A	1	5011
08 B	2	5012
10 B	3	5013
05 B	4	5014
20 B, 16 A, 16 B	5	5015
12 A	6	5016
24 B	7	5017
Fetching up punch C		
05 B	1	40006688
06 B	3	40006689
Company norm 1/2"	4	40006692
08 A	5	40006691
08 B	6	40006690
10 B	7	40006693
10 A	8	40006694
12 B	9	40006695
12 A	10	40006696
16 A	11	40006705
16 B	12	40006697
20 B	13	40006698
24 B	14	40006699

DIN ISO No.	No.	Art-No.
Reveting plate D1		
05 B-16 B, 08 A-16 A	1	5024
20 B, 24 B	2	5025
Insert D2		
05 B, 06 B	1	5026
08 A, 08 B, 10 B	2	5027
10 A, 12 A, 12 B	3	5028
16 A, 16 B	4	5029
20 B	5	5030
-	6	5031
24 B	8	5032
Bush D3		
05 B, 06 B	1	5033
08 A, 10 A	2	5034
12 A, 16 A	3	5035
24 B	4	5036
-	5	5037
Riveting punch E		
05 B, 06 B	1	5038
08 A, 08 B, 10 B	2	5039
10 A, 12 A, 12 B	3	5040
16 A, 16 B	4	5041
20 B	5	5042
-	6	5043
24 B	7	5044

Notes

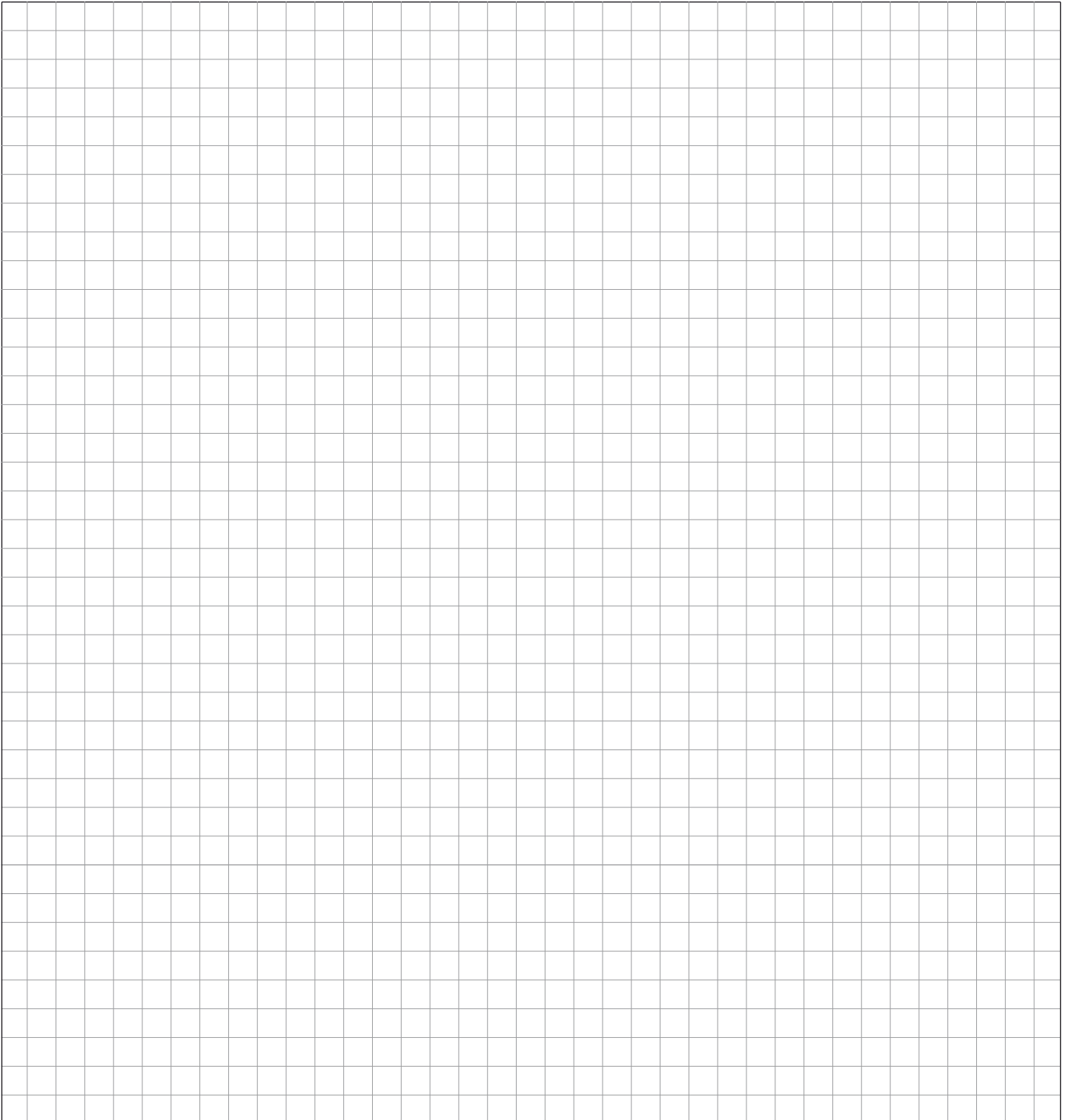



JWIS[®] Automatic tensioners

Automatic chain tensioners compensate the chain elongation in the machines and conveyor systems and that way further the run time of the applied chain. iwis chain tensioners are made from high quality materials. Depending on the application various types are available.



iwis® RHR Type with sprocket and bearing

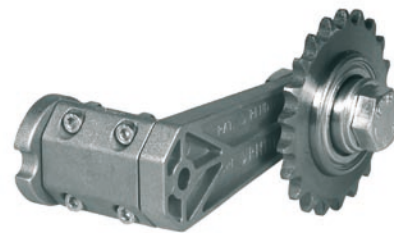

	chain pitch	Newton	A ± 1	B	C	D	E	F	G	H ± 1	L	Q	R	S	T	U	V	N°	
Type RHR																			
RHR 111	3/8" x 7/32"	0÷100	58	6	8	35	80	M6	8,5	51	8	22	5	9,2	19,7	9,7	16,7	21	
RHR 155	3/8" x 7/32"	0÷150	71	8	8,5	45	100	M8	10,5	64	8	30	6	9,2	19,7	9,7	16,7	21	
RHR 155	1/2" x 5/16"	0÷150	71	8	8,5	45	100	M8	10,5	64	8	30	6	9,2	19,7	12,5	19,5	16	
RHR 188	1/2" x 5/16"	0÷300	84	10,5	8,5	58	100	M10	13	78	10	37	8	9,2	19,7	12,5	19,5	16	
RHR 188	5/8" x 3/8"	0÷300	85	10,5	8,5	58	100	M10	13	78	10	37	8	9,2	19,7	15,3	23,3	17	
RHR 277	3/4" x 7/16"	0÷900	114	15	10,5	78	130	M12	17	107	12	53	10	9,2	19,7	17,7	25,7	15	
RHR 277	1" x 17 mm	0÷900	114	15	10,5	78	130	M12	17	107	12	53	10	8,9	19,4	26,4	34,4	12	

TYPE RHR

- Good damping effect, reducing noise and vibration
- Operating angle > 30° in both directions of rotation
- Simple screw mounting, internally or externally
- Operational temperature > 65°C
- Applies to reverse direction drives
- Interchangeable to similar systems

EXAMPLE OF ORDER

Tensioner for 1/2" pitch single chain
RHR 155 1/2" S. For single chain available from stock. For double chain on request

S = single chain **D** = double chain

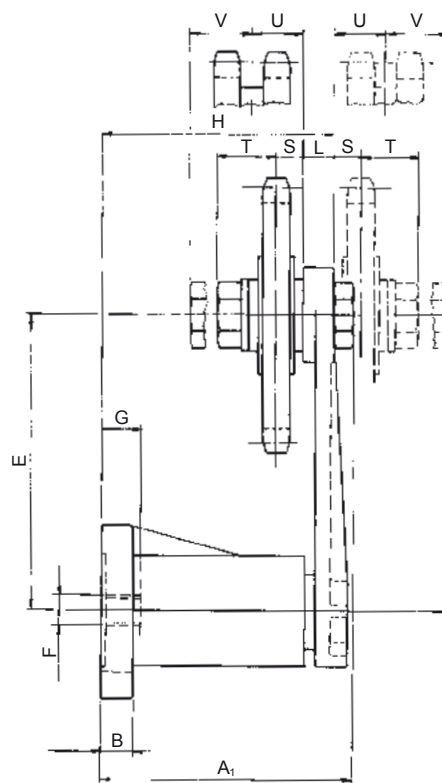
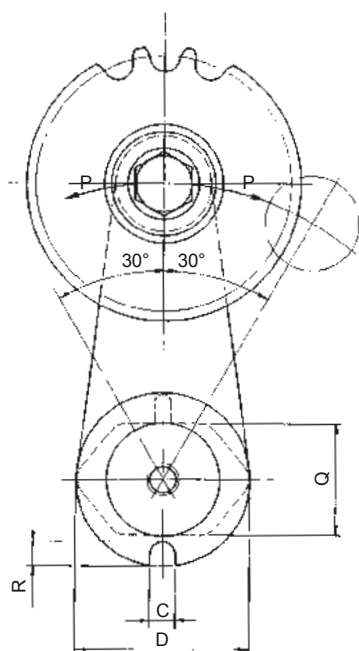

iwis® RHP Type

with low friction coefficient polythene head



	chain pitch	Newton	A±1	B	C	D	E	F	G	H±1	L	M	N	O	R	S	T	U	V	Z
Type RHP																				
RHP 111	3/8" x 7/32"	0÷100	57	6	8	35	80	M6	8,5	51	8	20	7	22	5	4	70	20	25	102
RHP 155	3/8" x 7/32"	0÷150	70	8	8,5	45	100	M8	10,5	64	8	20	7	30	6	4	70	20	25	122
RHP 155	1/2" x 5/16"	0÷150	70	8	8,5	45	100	M8	10,5	64	8	20	7	30	6	4	70	20	35	122
RHP 188	1/2" x 5/16"	0÷300	84	10,5	8,5	58	100	M10	13	78	10	20	7	37	8	4	70	20	35	122
RHP 188	5/8" x 3/8"	0÷300	85	10,5	8,5	58	100	M10	13	78	10	22	8	37	8	5	90	25	41,5	129
RHP 277	3/4" x 7/16"	0÷900	114	15	10,5	78	130	M12	17	107	12	22	8	53	10	5	90	30	49	159
RHP 277	1" x 17 mm	0÷900	114	15	10,5	78	130	M12	17	107	12	25	8	53	10	5	110	45	78	165

EXAMPLE OF ORDER

Tensioner for 1/2" pitch single chain
 RHP 155 1/2" S. For single chain available
 from stock. For double chain on request.

S = single chain **D** = double chain

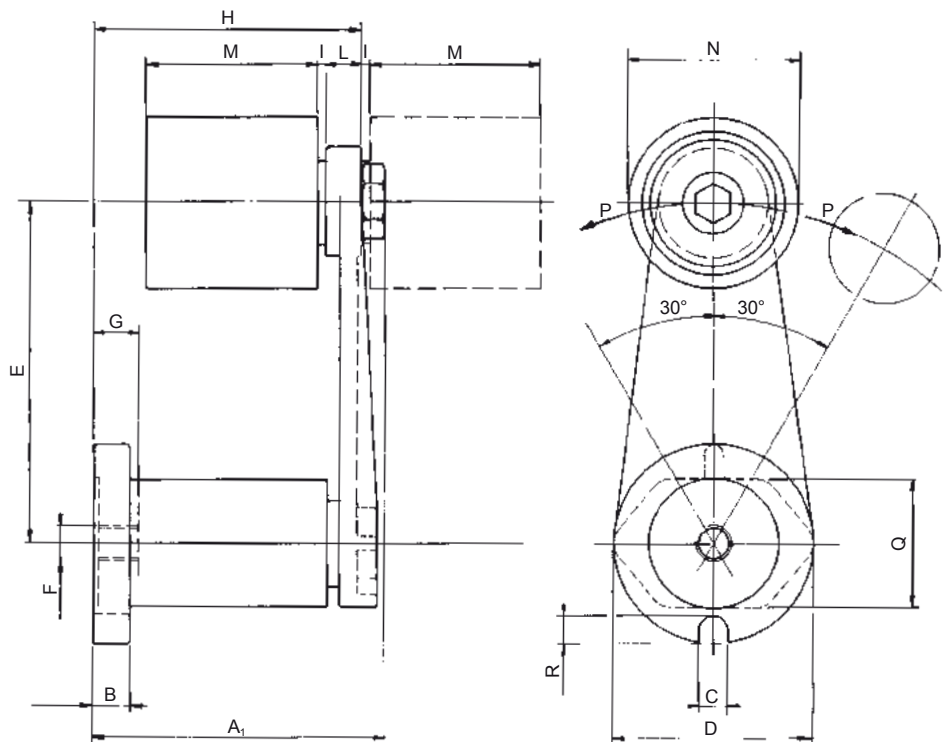

iwis® TCR Type
with spocket and bearing



Type TCR	Newton		chain pitch	N°	A	B	C	CH	D	E	F	G	H	I	L	M	N	O	P	β
	min.	max.																		
*TCR-05 – 3/8"	80	160	3/8" x 7/32"	21	5	15	15	24	63	35	23	23	75,5	9,2	119	M10	19,7	-	-	45°
TCR-1 – 3/8"	100	210	3/8" x 7/32"	21	5	15,5	15,5	24	69	36	30	25	86,5	9,2	134	M10	19,7	18	11	45°
TCR-1 – 1/2"	100	210	1/2" x 5/16"	16	5	15,5	15,5	24	69	36	30	25	86,5	9,2	134	M10	19,7	16,5	12,5	45°
TCR-1 – 5/8"	120	240	5/8" x 3/8"	17	5	15,5	15,5	24	69	36	30	25	86,5	9,2	134	M10	19,7	21,8	15,3	45°
TCR-2 – 5/8"	200	350	5/8" x 3/8"	17	7	18	18	27	90	43	34	30	100	9,2	159	M12	19,7	21,8	15,3	30°
TCR-2 – 3/4"	200	350	3/4" x 7/16"	15	7	18	18	27	90	43	34	30	100	9,2	159	M12	19,7	19,4	17,7	30°
TCR-2 – 1"	240	380	1" x 17 mm	12	7	18	18	27	90	43	34	30	100	8,9	159	M12	19,4	23,9	26,4	30°
TCR-2 – 1 1/4"	240	380	1 1/4" x 3/4"	9	7	18	18	27	90	43	34	30	100	11,5	159	M12	19,4	-	-	30°
TCR-2 – 1 1/2"	240	380	1 1/2" x 1"	9	7	18	18	27	90	43	34	30	100	14	159	M12	19,4	-	-	30°

* Plastic version

TYPE TC

- Linear force progression
- Operating angle > 45° in both directions of rotation
- Simple screw mounting, internally or externally
- Operational temperature to 100°C
- Applies to reverse direction drives
- Resistant against oil and solvents
- better fastening due to 2 (TCR-1) resp. 3 (TCR-2) grooves

EXAMPLE OF ORDER

Tensioner for 1/2" pitch single chain TCP 1 1/2" S. For single chain available from stock. For double chain on request.

S = single chain **D** = double chain

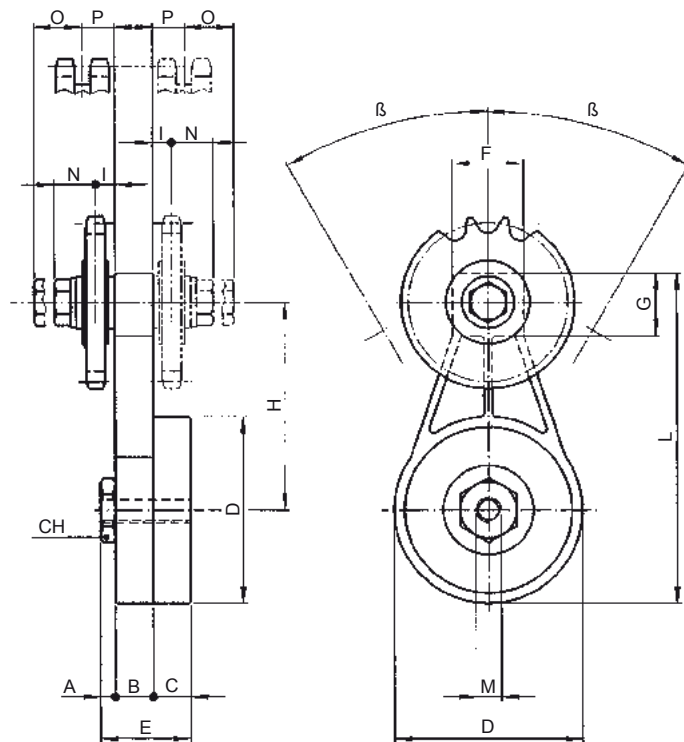

iwis® TCP Type

with low friction coefficient polythene head



Typ TCP	Newton		chain pitch	A	B	C	CH	D	E	F	G	H	I	L	M	N	O	P	Q	β
	min.	max.																		
TCP-05 – 3/8"	80	160	3/8" x 7/32"	5	15	15	24	63	35	23	23	75,5	5,5	119	M10	70	20		22	45°
TCP-1 – 3/8"	100	210	3/8" x 7/32"	5	15,5	15,5	24	69	36	30	25	86,5	7	134	M10	70	20	20	22	45°
TCP-1 – 1/2"	100	210	1/2" x 5/16"	5	15,5	15,5	24	69	36	30	25	86,5	7	134	M10	70	20	20	22	45°
TCP-1 – 5/8"	120	240	5/8" x 3/8"	5	15,5	15,5	24	69	36	30	25	86,5	7	134	M10	90	22	25	29	45°
TCP-2 – 5/8"	200	350	5/8" x 3/8"	7	18	18	27	90	43	34	30	100	8	159	M12	90	22	25	29	30°
TCP-2 – 3/4"	200	350	3/4" x 7/16"	7	18	18	27	90	43	34	30	100	8	159	M12	90	22	30	29	30°
TCP-2 – 1"	240	380	1" x 17 mm	7	18	18	27	90	43	34	30	100	8	159	M12	110	25	45	35	30°

EXAMPLE OF ORDER

Tensioner for 1/2" pitch single chain
 TCP 1 – 1/2" S. For single chain available
 from stock. For double chain on request.

S = single chain **D** = double chain

NOTE

assembly instruction tensioner TC type
 → **Page 97**

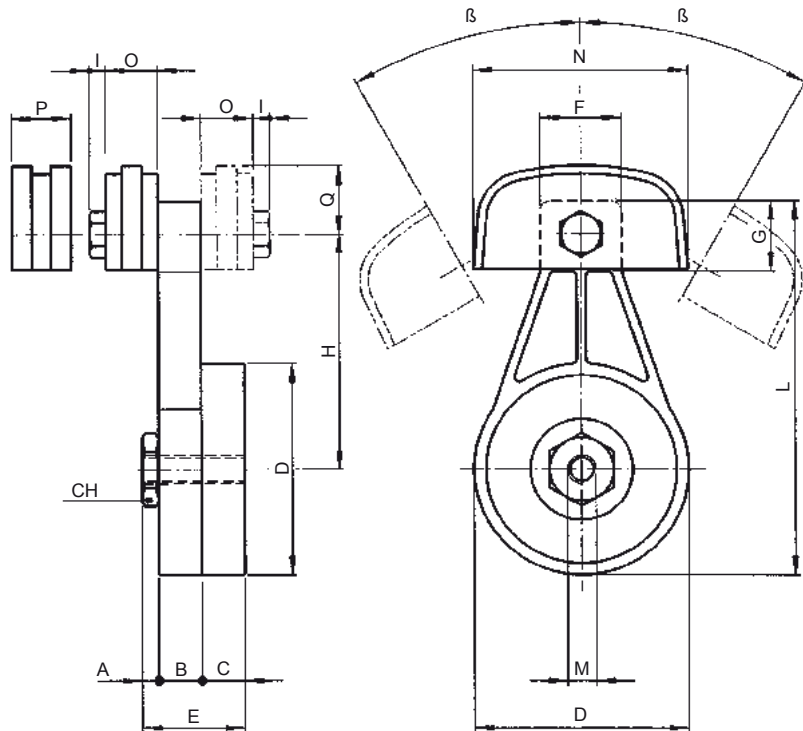

iwis® TO Series

Automatic chain tensioners

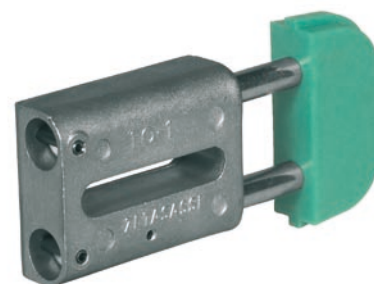

Type TO	Newton		chain pitch	A1	A2	A3	B	C	D	E	F	G	H	I	L	M	N	O	P	R
	min.	max.																		
TO-1 - 3/8"	130	250	3/8" x 7/32"	20	20	25	23	12,5	11	56,2	7	58	74	110	138	-	-	-	70	100
TO-1 - 1/2"	130	250	1/2" x 5/16"	20	20	25	23	12,5	11	56,2	7	58	74	110	138	-	-	-	70	100
TO-1 - 5/8"	130	250	5/8" x 3/8"	20	25	41,5	23	12,5	11	56,2	7	58	74	110	138	-	-	-	70	100
TO-2 - 5/8"	180	420	5/8" x 3/8"	22	25	41,5	28	15	12,5	70,5	9	70	87	133	169	-	-	-	90	120
TO-2 - 3/4"	180	420	3/4" x 7/16"	22	30	49	28	15	12,5	70,5	9	70	87	133	169	-	-	-	90	120
TO-3 - 1"	300	650	1" x 17 mm	25	45	78	33	17,5	14,5	82	9	86	104	160	202	21	35	70	110	140
TO-3 - 1 1/4"	300	650	1 1/4" x 3/4"	25	54	90	33	17,5	14,5	82	9	86	104	160	202	21	35	70	110	140
TO-3 - 1 1/2"	300	650	1 1/2" x 1"	25	71	119	33	17,5	14,5	82	9	86	104	160	202	21	35	70	110	140
TO-05 - 3/8"	95	190	3/8" x 7/32"	20	-	-	25	12,5	9	60	10	53	75	120	149	22	48	1,5	70	100
TO-05-DP1 -	95	190	3/8" x 7/32"	20	20	-	25	12,5	9	60	10	53	75	111	139	22	48	1,5	70	100
TO-05-DP1 -	95	190	1/2" x 5/16"	20	20	-	25	12,5	9	60	10	53	75	111	139	22	48	1,5	70	100
TO-05-DP1 -	95	190	5/8" x 3/8"	20	25	-	25	12,5	9	60	10	53	75	111	139	22	48	1,5	70	100

AUTOMATIC CHAIN TENSIONERS

The automatic tensioners take up the chain slackening and keep the tension constant, without any operator attending the adjustment. The TO-AT-ET tighteners are designed to last and are made of top quality materials. The maximum operating temperature is 65°C (100°C for the ET model only).

Available on request:

1. Studs and spring in stainless steel
AISI 304 for the Food industry
2. Special head shapes
3. Version TO-05 and TO-05 DP1 with basic body in plastic execution (DELFIN).
Slight type with lower tensioning force – available on request.

* Plastic version

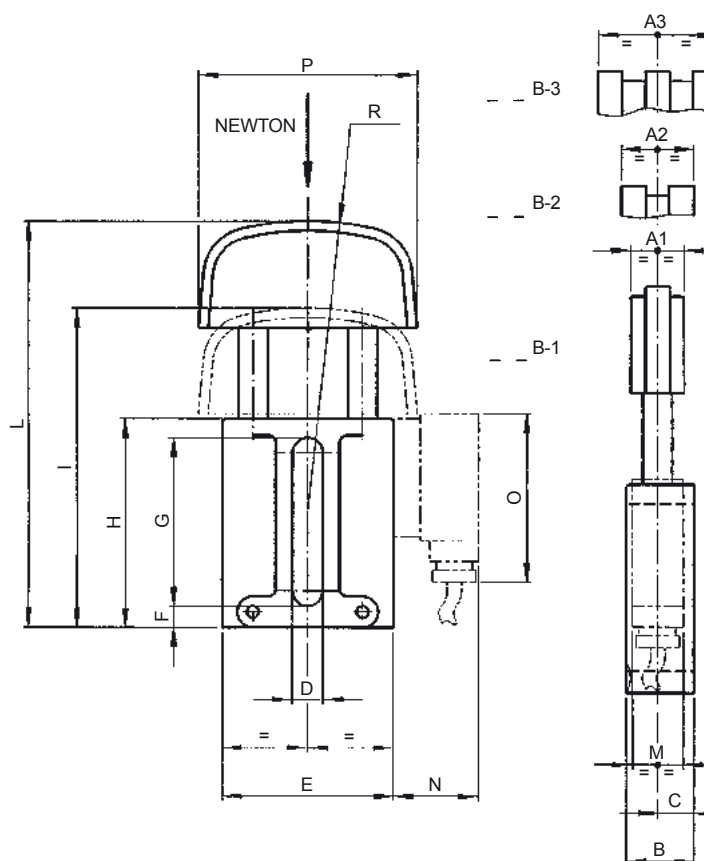

iwis® TA Series



Type TA	Newton		chain pitch	A1	A2	A3	B	C	D	E	F	G	H	I	L	M	N	O	P	R	
	min.	max.																			
TA-1 - 3/8"	130	250	3/8" x 7/32"	20	20	25	23	12,5	11	56,2	7	58	74	115	143					140	120
TA-1 - 1/2"	130	250	1/2" x 5/16"	20	20	35	23	12,5	11	56,2	7	58	74	115	143					140	120
TA-2 - 5/8"	180	420	5/8" x 3/8"	22	25	41,5	28	15	12,5	70,5	9	70	87	128	164					140	140
TA-2 - 3/4"	180	420	3/4" x 7/16"	22	30	49	28	15	12,5	70,5	9	70	87	128	164					140	140
TA-3 - 1"	300	650	1" x 17 mm	25	45	78	33	17,5	14,5	82	9	86	104	145	187	21	35	70	140	160	
TA-3 - 1 1/4"	300	650	1 1/4" x 3/4"	25	54	90	33	17,5	14,5	82	9	86	104	145	187	21	35	70	140	160	
TA-3 - 1 1/2"	300	650	1 1/2" x 1"	25	71	119	33	17,5	14,5	82	9	86	104	145	187	21	35	70	140	160	
TA-3 - 1 3/4"	300	650	1 3/4" x 31 mm	29,5	-	-	33	17,5	14,5	82	9	86	104	145	187	21	35	70	140	160	

TA SERIES

- Tensioning head made of low friction coefficient special wearproof plastic (dynamic friction coefficient 0.06 on dry steel)
- High tensile steel ground studs
- Self-lubricating bearings for axial slide

EXAMPLE OF ORDER

Tensioner for 1/2" pitch double chain
 TA 1 - 1/2" D

S = single chain **D** = double chain
T = triple chain

N.B.: Our tensioners are supplied for chains complying to ISO standards.

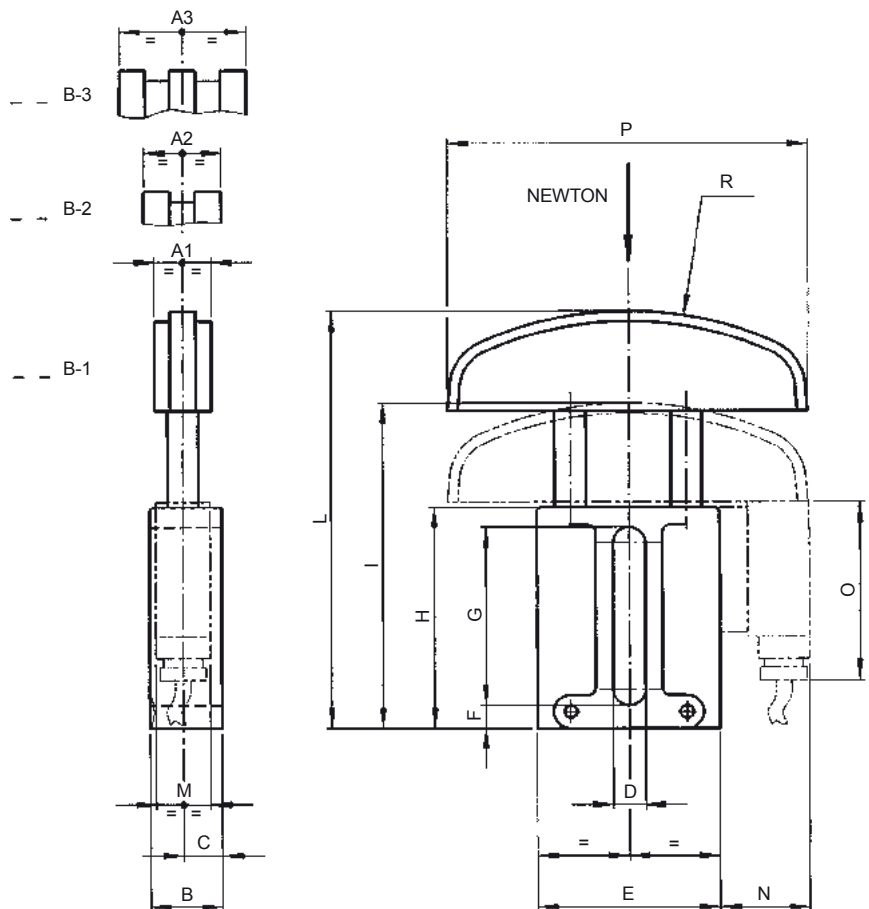

iwis® ETR Series
with sprocket and bearing

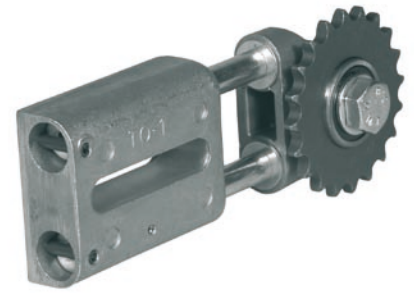

Type ETR	Newton		chain pitch	Z	A	B	C	D	E	F	G	H	I	L	M	N	O	P	Q	R	S
	min.	max.																			
ETR1 – 3/8"	130	250	3/8" x 7/32"	21	20	23	12,5	11	56,2	7	58	74	99	127	-	-	-	11	19,7	9,2	18
ETR1 – 1/2"	130	250	1/2" x 5/16"	16	20	23	12,5	11	56,2	7	58	74	99	127	-	-	-	12,5	19,7	9,2	16,5
ETR2 – 5/8"	180	420	5/8" x 3/8"	17	25	28	15	12,5	70,5	9	70	87	127	163	-	-	-	15,3	19,7	9,2	21,8
ETR2 – 3/4"	180	420	3/4" x 7/16"	15	25	28	15	12,5	70,5	9	70	87	127	163	-	-	-	17,7	19,7	9,2	19,4
ETR3 – 1"	300	650	1" x 17 mm	12	30	33	17,5	14,5	82	9	86	104	151	193	21	35	70	26,4	19,4	8,9	26,4
ETR3 – 1 1/4"	300	650	1 1/4" x 3/4"	9	30	33	17,5	14,5	82	9	86	104	151	193	-	-	-	29,7	19,4	11,5	37,5

ETR SERIES

- Maintenance free
- Tensioning force changeable (option)
- Resistant against oil and solvents
- Simply mounting and adjustment
- Applies to reverse direction drives

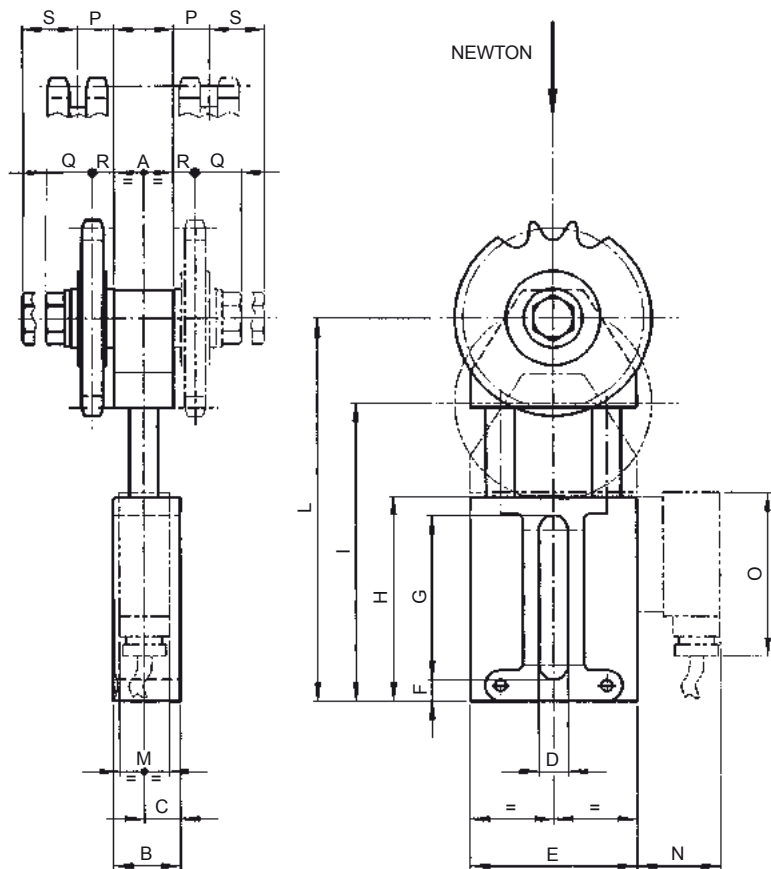

iwis® TF Series
 Plastic tightening head

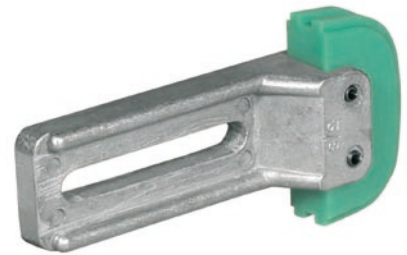

	chain pitch	A	B	C	D	E	F	G	H	I	L	N	R	A1	A2	A3
Type TF																
TF 1	3/8"	69	35	138	10	73	10,5	40	10	15	30	15	15	20	20	
TF 1	1/2"	69	35	138	10	73	10,5	40	10	15	30	15	15,25	20	20,5	
TF 2	5/8"	89	45	164	12	85	12,5	50	12	18	36	18	19,5	22	25	
TF 2	3/4"	89	45	164	12	85	12,5	50	12	18	36	18	21,75	22	29,5	
TF 3	1"	109	55	173	13	82	12,5	60	14	20	40	20	30,5	25	46	
TF 3	1 1/4"	109	55	173	13	82	12,5	60	14	20	40	20	-	25	-	
TF 3	1 1/2"	109	55	173	13	82	12,5	60	14	20	40	20	-	25	-	

TF TYPE

- Wear resistant tensioning head in low friction ($\mu = 0.06$) plastic
- Simple mounting and adjustment
- Operational temperature to 65°C

EXAMPLE OF ORDER

Tensioner for 1/2" pitch double chain
 TF 1 – 1/2" D

S = single chain **D** = double chain
T = triple chain

Our tensioners are supplied for chains complying to ISO standards.

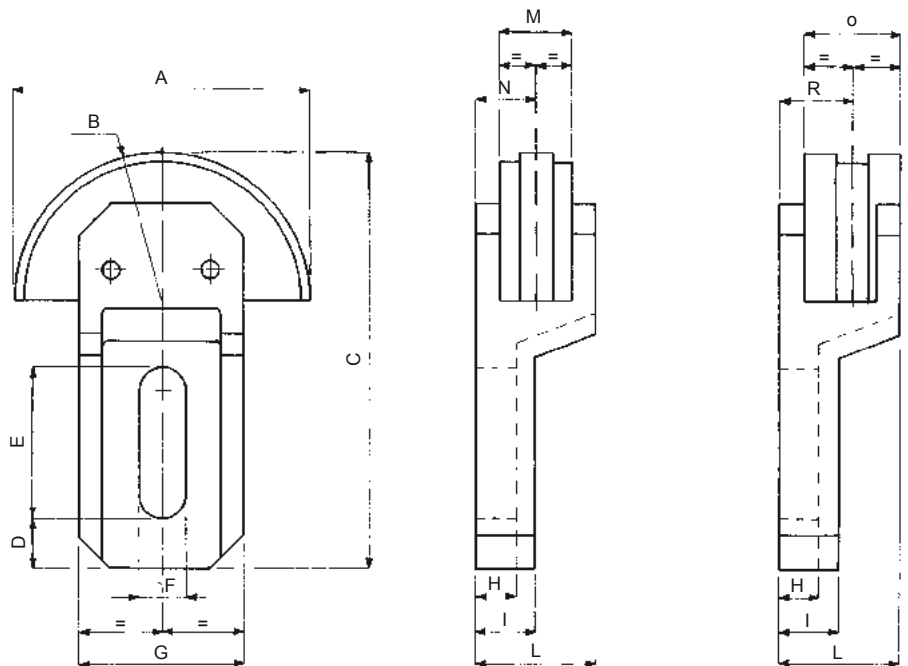

iwis® Chain Tensioner AMS



for iwis chain	DIN ISO no.	Tensioning Unit No.	No. of teeth z	Tensioning force N	Tensioning path S mm	Adjusting range mm	Dimensions A mm	Dimensions B mm	Basic element No.	Support bracket No.	Tensioner complete with wheel
Type AMS											
G 67	06 B-1	10	21	0-100	0-25	60	47,6	39,4	AMS 11	01	AMS 116
G 67	06 B-1	10	21	0-100	0-25	60	47,6	39,4	AMS 12	02	AMS 126
L 85	08 B-1	10	18	0-100	0-25	60	47,6	39,4	AMS 11	01	AMS 118
L 85	08 B-1	10	18	0-100	0-25	60	47,6	39,4	AMS 12	02	AMS 128
M 106	10 B-1	10	17	0-100	0-25	60	47,6	39,4	AMS 11	01	AMS 1110
M 106	10 B-1	10	17	0-100	0-25	60	47,6	39,4	AMS 12	02	AMS 1210
M 127	12 B-1	20	15	0-300	0-45	40	52,0	40,0	AMS 23	03	AMS 2312
M 1611	16 B-1	20	12	0-300	0-45	40	52,65	41,3	AMS 23	03	AMS 2316

AMS TYPE

- Automatic retensioning
- Pawl and ratchet rebound safety mechanism
- Constant vibration damping
- Simple adjusting device
- Low in maintenance
- Resistant against oil and solvents

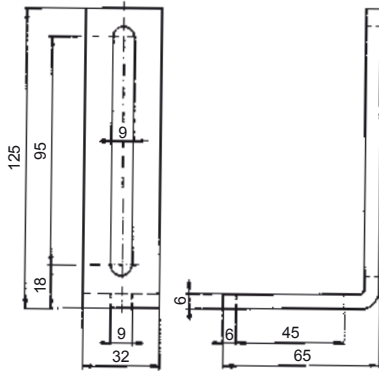

support bracket 01

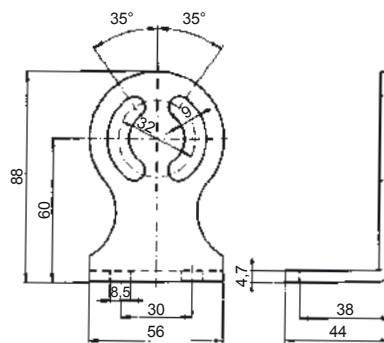

support bracket 02

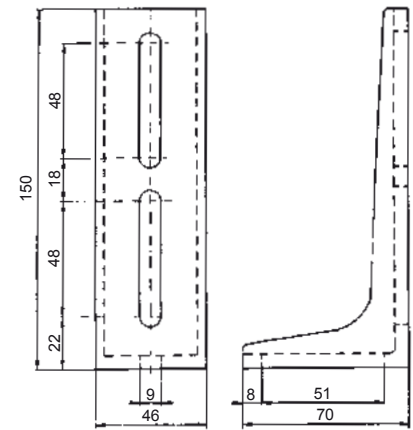

support bracket 03

iwis® Chain Tensioner AMS



AMS 10 **AMS 20**

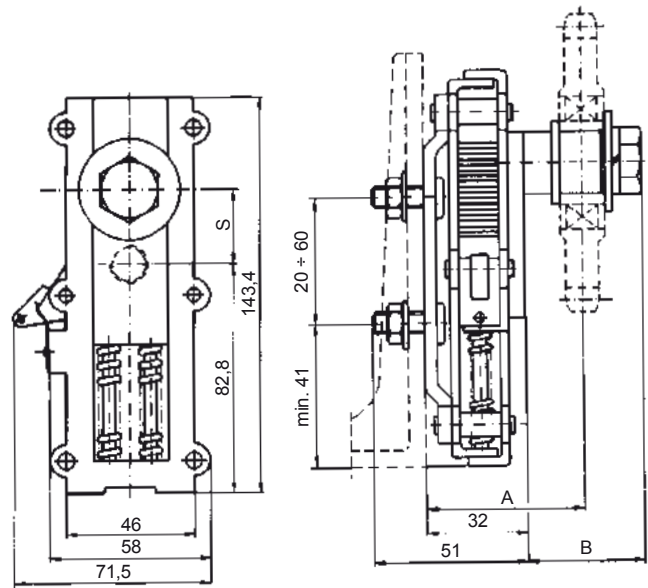
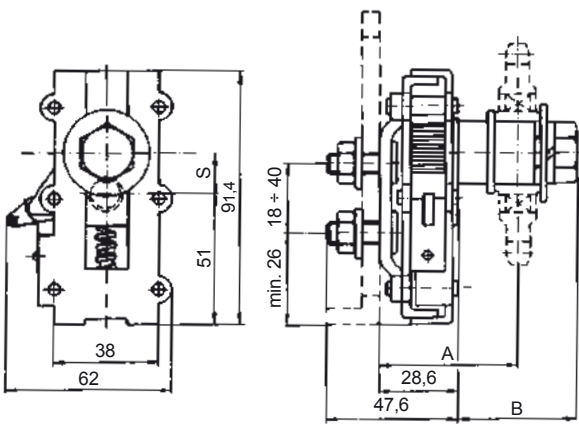

iwis® TC Type
 Tensioner assembly TC Type



ALTERNATIVE A **ALTERNATIVE B** **CORRECT ASSEMBLY** **WRONG ASSEMBLY**

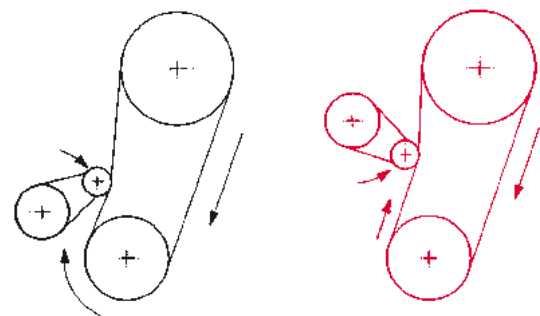
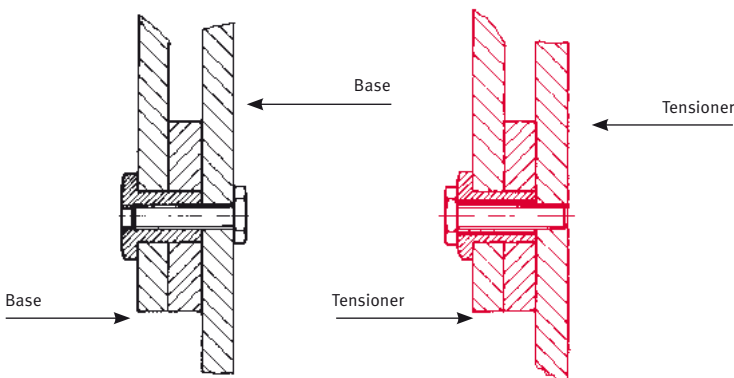



JWTS[®] Chain guide

Regular maintenance and lubrication are preconditions for low wear and long service life of the chain drive. The maintenance and lubrication frequency, as well as the related re-lubrication, are determined by the operating conditions of the application. The iwis chain guide outlines the choice of possible chain lubrications and recommended re-lubricants. All initial lubricants are developed especially for iwis and their composition is tailored to be the best possible for the product chain. Please contact our Technical Service Team for more information regarding the maintenance and handling of chains. We will happily advise you!



Lubricating the **iwis**® chains iwis chain lubricants

OUR CHAIN LUBRICANTS - THE BEST POSSIBLE SOLUTION FOR EVERY APPLICATION.

Sufficient and effective lubrication increases the length of life of the chains several times over. The selection of the correct lubricant and the appropriate method of lubrication guarantee good reduction of wear, sufficient protection from corrosion and optional damping characteristics. Countless trials on specially developed test equipment and close collaboration with well known lubricant manufacturers make iwis your competent partner for all questions relating to chain lubrication.

All iwis chains are provided with sufficient, reliable, high quality initial lubrication in accordance with precisely stipulated procedures, which are the subject of constant monitoring, and delivered ready for installation. All the initial lubricants are developed especially for iwis and their composition is tailored to be the best possible for the chain product.

A SUMMARY OF OUR INITIAL LUBRICANTS

IP2 the proven standard lubricant with a good lubricating effect and excellent corrosion protection for applications of all kinds from -10° to +80°C.

IP3 long-lasting lubrication at higher speeds, loads and temperatures. As a consequence of its high viscosity, it is absolutely resistant to spinning off over the entire temperature range from -5° to +150°C.

IPW the handling-resistant high performance lubricating wax with very high wear protection permits significantly longer intervals between applications of lubricant. Problem-free use as a „barrier grease“ in all environments where dust and powder are present. Temperature range from -10° to +80°C.

IP4 thermally stable high temperature lubricant with good wear- and corrosion-resistance. Low evaporation rate in the temperature range from 0° to +250°C. Forms no residue at temperatures above 250°C.

IP9 the corrosion-protection for preservative use with a very low lubricant effect. Temperature range from 0° to +70°C.

IP14 dry lubricant for slow-running chain drives and low to medium loads. Stove enamel with built-in lubricant for applications from -70° to +250°C.

IP16 the lubricant for food use with good wear- and corrosion-resistance. Meets the requirements of USDA-H1 and LMBG - authorised for contact with food. Temperature range from -20° to +130°C.

IPO low temperature lubricant with optimum lubricating effect. Able to flow in the entire temperature range from -45° to +150°C.

Re-lubrication of the **iwis**® chains

Re-lubricants

RE-LUBRICATION

The life of a chain is dependent to a decisive extent on correct and adequate topping up of the lubricant. As a consequence of the oscillating movements of the chain link, the initial lubricant is used up in the course of time depending on the operating conditions. If the lubricant is topped up regularly, the chain is mainly within the range of fluid and mixed friction. An absence of lubricant or badly selected re-lubricants cause dry friction, which leads to the formation of fretting corrosion and increased wear of the chain.

The selection of the lubricant and the correct lubrication technique is decisive for effective re-lubrication.

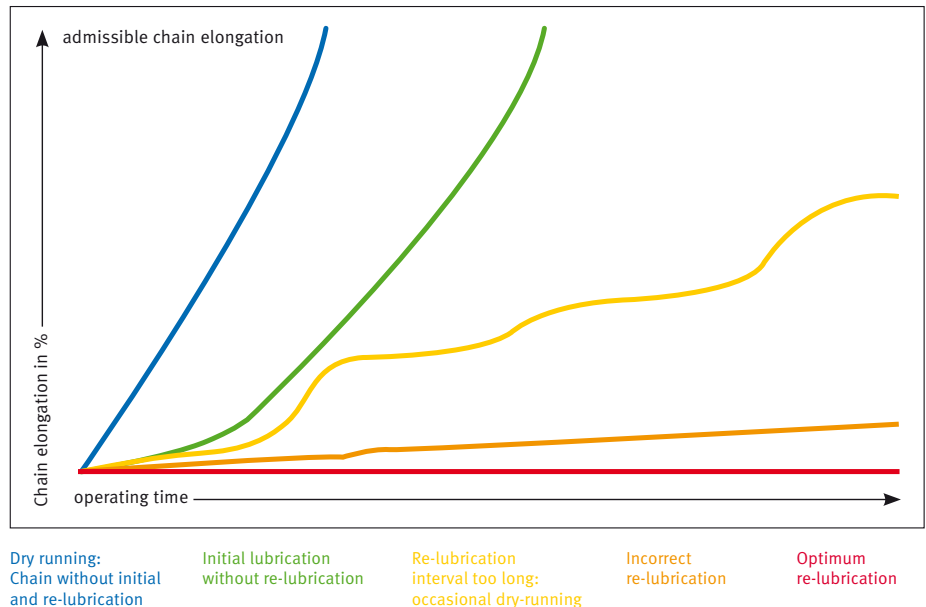

RECOMMENDED RE-LUBRICANTS FOR OUR INITIAL LUBRICANTS

- IP2** iwis VP6 Kombi superplus (spray)
All standard commercial chain oils
- IP3** iwis VP6 Kombi superplus (spray)
High performance chain oils from various manufacturers, e.g. STRUCTOVIS HD-series from Klüber Lubrication
- IPW** iwis VP6-Kombi superplus (spray)
High performance chain oils from various manufacturers, e.g. STRUCTOVIS HD-series from Klüber Lubrication
- IP4** iwis VP6-Kombi superplus (spray)
High temperature chain oils from various manufacturers, for temperatures above 250°C with proportions of solid lubricant

- IP9** iwis VP6-Kombi superplus (spray)
All conventional chain oils
- IP14** iwis VP6-Kombi superplus (spray)
Chain oils containing a proportion of solid lubricant such as graphite, MOS2
- IP16** chain oils approved for food use, e.g. Klüberoil UH 1-series
- IPO** low temperature chain oils from various manufacturers

RE-LUBRICANTS

should possess the following characteristics - depending on the application:

- Adhesiveness
- Compatibility with initial lubricant
- Corrosion protection
- Load-bearing capacity of lubricant film
- Ability to creep
- Lubrication of emergency running
- High viscosity and simultaneous ability to flow
- High temperature stability
- Water-repellent
- Resistance to media etc.

■ Designation initial lubricant
 ■ Recommendation re-lubricant

Lubricating the **iwis**® chains

Lubrication techniques

MANUAL LUBRICATION

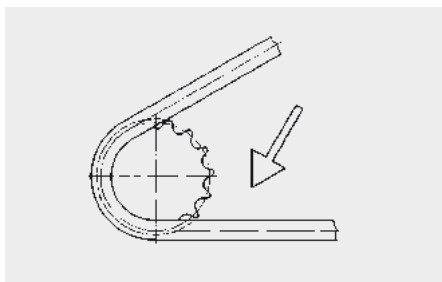

Using a paint brush, oil can or spray can for slow-running chain drives. The proven VP6-Kombi superplus (spray) is distinguished by the following characteristics:

- Synthetic high performance chain lubricant
- Optimum lubricating effect and adhesion
- Excellent ability to creep
- For normal and high temperature use up to +250°C
- Excellent corrosion protection
- Also well suited to O-seal chains

RECOMMENDATIONS

The chain drive should be cleaned with a brush before the lubricant is topped up to enable the lubricant to enter. In addition the surface of the chain can be cleaned with cleaner's naphtha or petroleum. Full submersion and washing out is not recommended.

Connecting elements (for example, connecting links), when supplied separately, have only been immersion-protected against rust and must be greased upon installation. If the connecting links are supplied together with the chains, they will have been greased with the same lubricant as the chains.

DRIP LUBRICATION

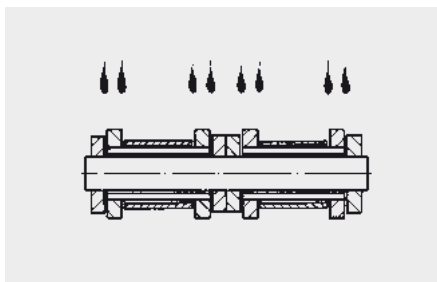

Using drip oilers, automatic lubricant feed or central lubrication units at medium chain speeds.

OIL BATH LUBRICATION

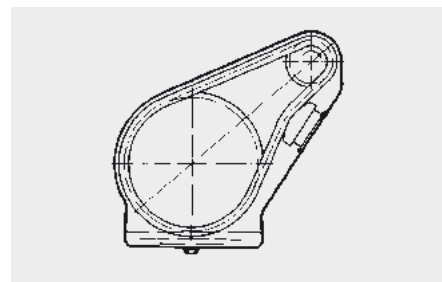

Using enclosed chain boxes and, if necessary, additional centrifugal disc for fast-running chain drives

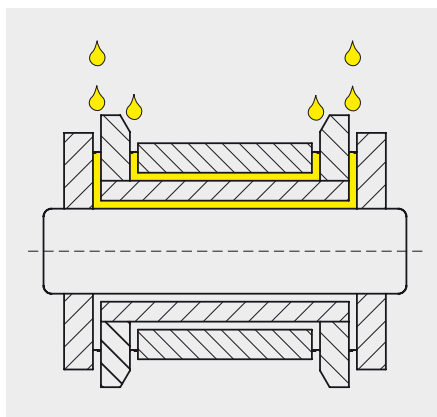

The lubricant product must be able to penetrate into the bearing area of the chain. To guarantee this the lubricant must be applied deliberately to the gap between the inner and outer plates.

Efficient chain maintenance

Regular maintenance and lubrication are preconditions for low wear and long service life of the chain drive. Maintenance and lubrication frequency, as well as the related re-lubrication, is determined by operating conditions (tensile forces, temperature, contamination, aggressive media).

MEASUREMENT OF STRETCHING DUE TO WEAR

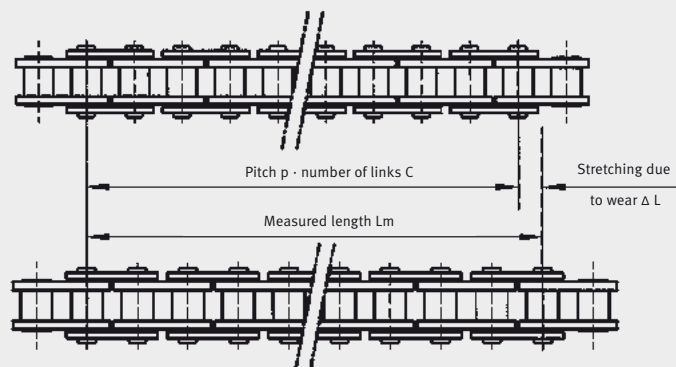

$$\Delta L = \frac{L_m - (p \cdot X)}{p \cdot X} \cdot 100 [\%]$$

MAINTENANCE

During **regular visual inspections** special attention should be paid to **stretching due to wear, tension, lubrication condition, and evidence of wear due to tracking errors.**

Checking the maximum permissible stretching due to wear:

The length of a chain is defined by the pitch p and the number of links X . In the course of time stretching due to wear occurs, and usually this can be measured without removing the chain. The difference from precise measurement with a specified measurement load is slight if measurements are conducted over the highest possible number of chain links, approximately 20 to 40.

The **chain should be replaced** at:

- max. 3 % for simple drives
- max. 2 % for high-performance drives
- max. 1 % for special applications (synchronous operation, positioning)

Controlled **retensioning** of the chains has a very positive effect on the chain life. Extreme retensioning should be avoided just as much as excessive slack. A guideline figure would be a tension load of approx. 5 % of the actual chain pulling force. In the case of chains running in parallel both strands must be tensioned equally, at best by a common shaft for both sprockets. If no automatic chain tensioning device is available, the chain must be adjusted by hand by altering the distance between the sprocket shafts. A further possibility with long drives is to shorten the chain by removing individual links, provided that wear is relatively light. Various tools are available for dismantling and reassembling the chain. These tools are available for parallel pin and shouldered pin chains.

Before **re-lubrication** the chains and sprockets should be **cleaned** to remove obstinate contamination and to permit the lubricant to penetrate via the back of the plates. The surface of the chain can also be cleaned using an appropriate solvent.

Complete immersion and washing is not recommended as the cleaning agent does not evaporate completely from within the chain and thus the penetration of the fresh lubricant is obstructed.

During **visual inspection** attention should be paid to evidence of chain linkplate marking and wear due to tracking errors. These are caused by misaligned sprockets or guides or by chains which are not in parallel.

Guide for alignment deviations per 100 mm axle separation:

- 0.1 mm with fast-running drives and close axle spacing;
- 0.2 mm with slow-running drives.

The sprockets should be constantly inspected and if necessary replaced. We do not recommend that new chains are used with worn sprockets.

iwis® chain guideline

Which application demands which chain type?

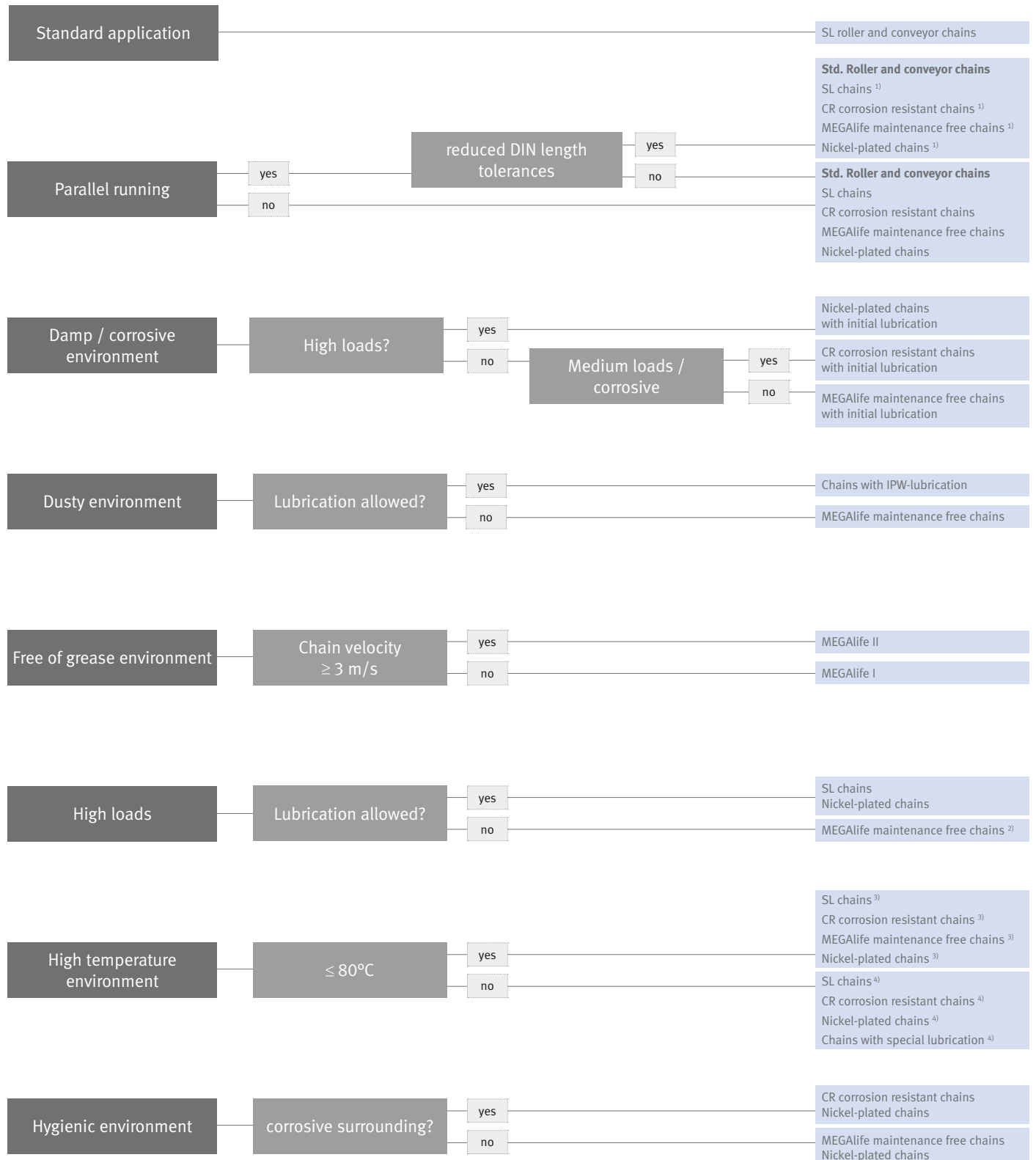

¹⁾ with reduced tolerances

²⁾ application limited ³⁾ with standard lubrication or IPW ⁴⁾ IP up to 150°C and IP4 up to 240°C

iwis® chain guideline

Important information and notes

IMPORTANT DETAIL

The following guidelines support you in choosing the right chain. However, please note that each application is individual. The result should in no case serve as a basis for your order. Therefore please refer to our professional employees who are happy to submit an individual order to you. We do not assume any guarantee or liability.

CHAIN ENGINEERING PROGRAM

iwis provides you with a special PC-Software serving as support for the specification of the individual chain drive design or rather the preselection of the appropriate chain. Please ask our Customer Service Team!

FOR MORE INFORMATION TO

- SL chains
→ Page **12** and **18**
- Nickel-plated chains
→ Page **12**
- MEGAlife maintenance free chains
→ Page **30**
- CR corrosion resistant chains
→ Page **40**

CHAIN FABRICATION LENGTHS

- 5 m
- 10 m
- 10 Fuß

Adjusted lengths can either be supplied open or closed. Special lengths (e.g. on coils) are available on request and depending on chain type.

OUR CONVEYOR CHAINS

If a parallel run is necessary, iwis can manufacture and supply chain strands with precisely harmonised lengths, bundled together and marked accordingly. This is in particular important for chains with opposite cam or angle side plates.

PRICE SUPPLEMENTS:

Price supplements will be calculated for:

- adjusted lengths
- special lubrications
- reduced tolerances
- short lengths
- special coatings
- nickel-plated chains and single parts
Prices on enquiry.

CUSTOM-MADE CHAINS

Special chains made according to customer drawings are possible. Prices on enquiry. Minimum order quantity is 50 m.

MINIMUM ORDER QUANTITIES FOR CONNECTORS AND CRANKED LINKS

Chain dimensions	Inner link / Outer link / Connecting link	Cottered Link
6 mm – 3/4"	20 ea	10 ea
1" – 1 1/4"	10 ea	10 ea
Duplex – Triplex	5 ea	5 ea
Parts over 1 1/4"	1 ea	1 ea

iwis® Questionnaire for chain drives

Enquiry from: _____ Date: _____

Address: _____ Dealt with by: _____

Telephone: _____

DRIVE (INPUT)

Electric, hydraulic, pneumatic combustion engines/motors (2, 4 or 6 cyls)?

Power output? kW

RPM? min⁻¹

Max. torque? at n = min⁻¹ Nm

Continuous power or peak power?

Speed constant, varying or impulsive?

Operating time, cyclic operation?

Are shock absorbing transmission-elements present (friction clutch)?

OUTPUT

Type of driven machine?

RPM? min⁻¹

Power requirement? for starting - normal running - max. kW

Load even, varying or impulsive?

Direction of rotation continuous or alternating? (show in diagram)

CHAIN DRIVE

Centre distance mm

Does the design allow the centre distance to be modified? ±

Possibility to provide tensioner? (adjustability, idler, chain guide)

Could the centre distance alter in service? e.g. rear wheel suspension on a motorcycle

Required or current ratio respectively?

Shafts horizontal or vertical?

Can the drive be protected against dirt and dust or can it be enclosed?

What type of lubrication is possible? (manual, drip, oil bath, pressure)

External factors? (temperature in °C, dust, moisture, fibres)

CHAIN

Chains planned or existing drive?

Is the chain replacing an existing drive?

Max. permissible chain width? mm

CHAIN WHEELS

No. of teeth? z₁ = z₂ =

Max. permissible outside diameter, incl. chain? mm

Chain wheel as a disc or with hub, predrilled or with finished bore?



www.juncor.pt

PORTAL B2B:

- Compras online
- Esclarecimento de dúvidas: Preços e Stocks
- Encomendas
- Licitação
- Descontos
- Eficiência e Segurança

Redes sociais

Facebook: www.facebook.com/juncor

Twitter: www.twitter.com/juncor_sa

LinkedIn: www.linkedin.com/company/juncor-sa

Canal Youtube: www.youtube.com/juncoraccess

“Adicionamos movimento ao seu negócio!”