

ContiTech

INSTALAÇÃO E EMPALME DE TAPETES TRANSPORTADORES TÊXTEIS

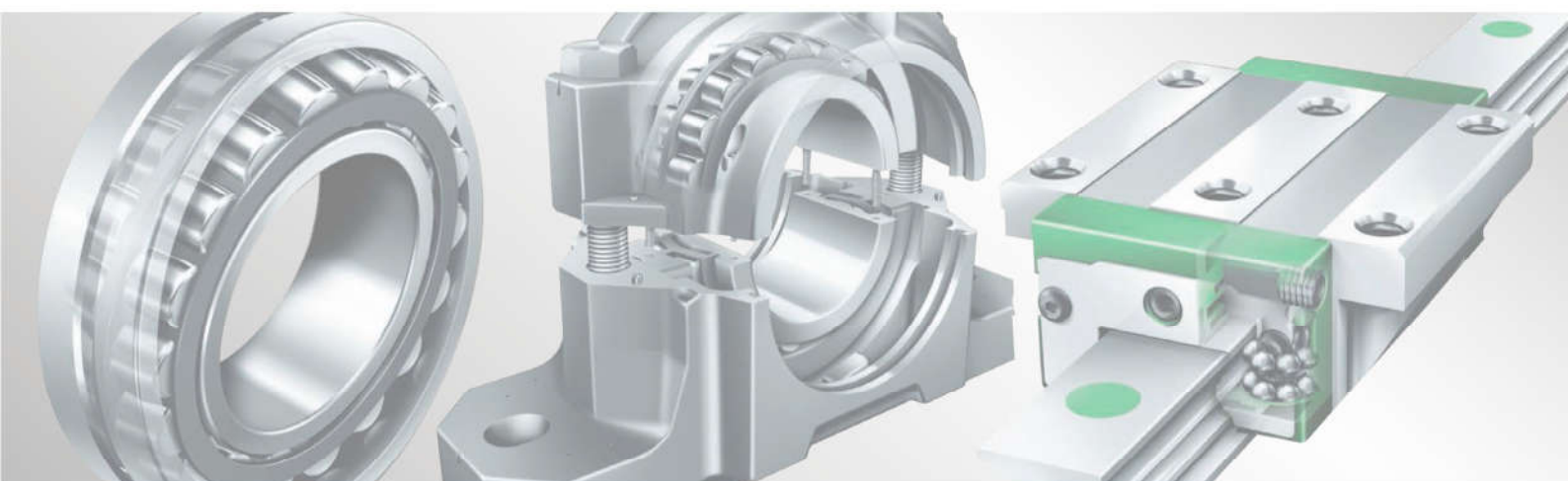
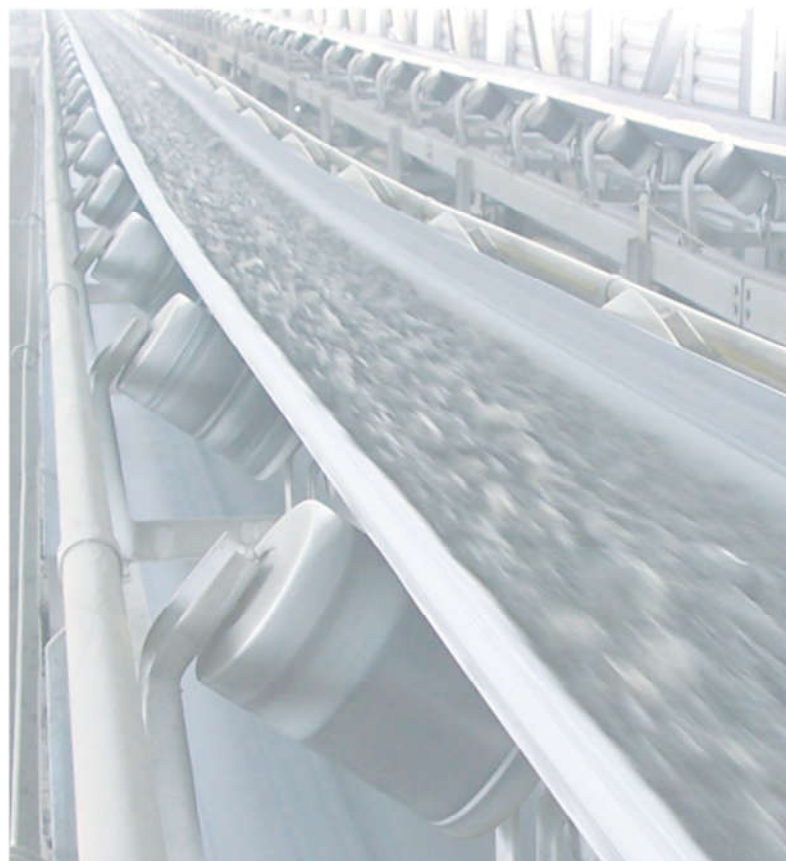

PRODUTO - SERVIÇO - ENGENHARIA

Edition

Installing and Splicing Textile Conveyor Belts

Conveyor Belt Group

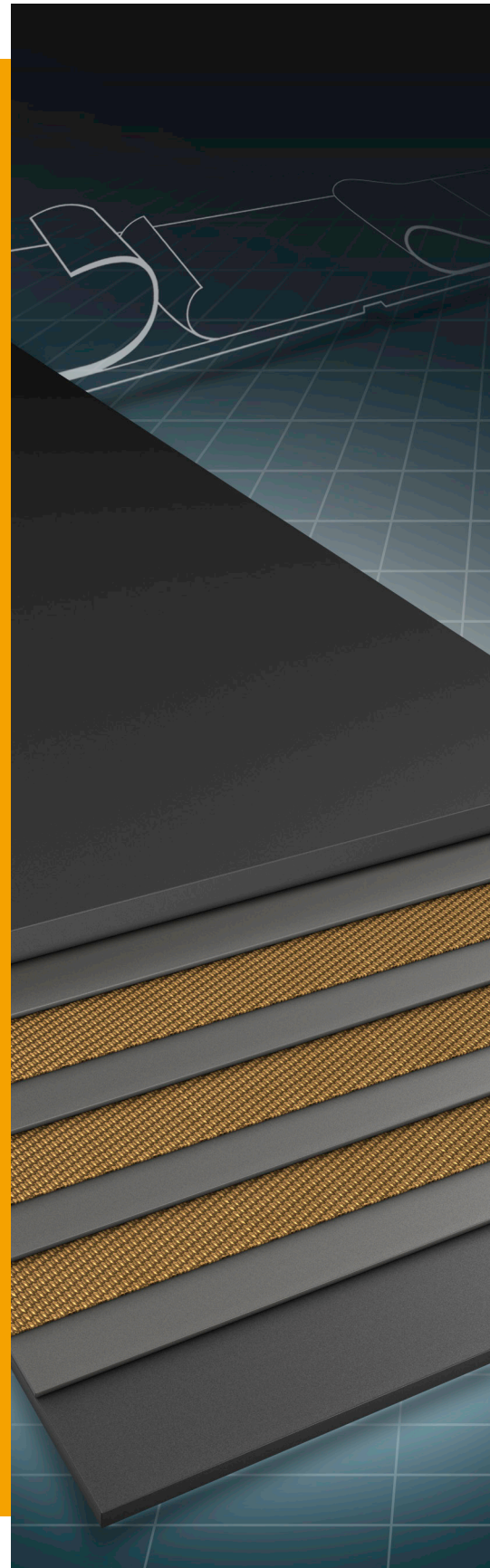

**ContiTech
Transportbandsysteme
GmbH**

We are a company of the ContiTech Group. 120 years of experience in rubber processing and a comprehensive range of products and services have made us the leading manufacturer of conveyor belts and service materials that meet various requirements in every industry. The product range extends from textile and steel conveyor belts to special conveyor belts with a wide variety of accessories.

Our products and services remain state-of-the-art thanks to continuous research and development based on careful basic research. We evaluate our ongoing material investigations and practical testing in collaboration with our raw materials suppliers. This gives rise to products that combine reliability and long life for every materials-handling task at an optimum cost/benefit ratio. We provide our customers with all-round service. It extends to consultation in planning conveyors and in-service product support

Conti Edition

This is the title of ContiTech's literature on conveying technology. Previously printed brochures provide information on product lines, accessories and maintenance instructions. Other subjects will be dealt with in the future.

**Conveyor Belts -
Installation and Splicing**

The operational reliability of conveyor belts is determined to a large extent by the strength of their splices. This brochure gives information on splicing. It also contains instructions on the proper method of installing conveyor belts and identifies the materials and tools needed for this. The summary of individual operations (listed in the appendix) will help belt installation and vulcanisation experts to plan and carry out their work.

The ContiTech Group is a development partner and an original equipment supplier to many industries, and it provides high-grade functional parts, components and systems. It is a part of the Continental Corporation with over 30 companies specializing in rubber and plastics technologies in Europe and sharing their common know-how.

This is what the ContiTech brand is all about.

ContiTech Textile Conveyor Belts - Ensuring Safe and Problem-Free Conveying

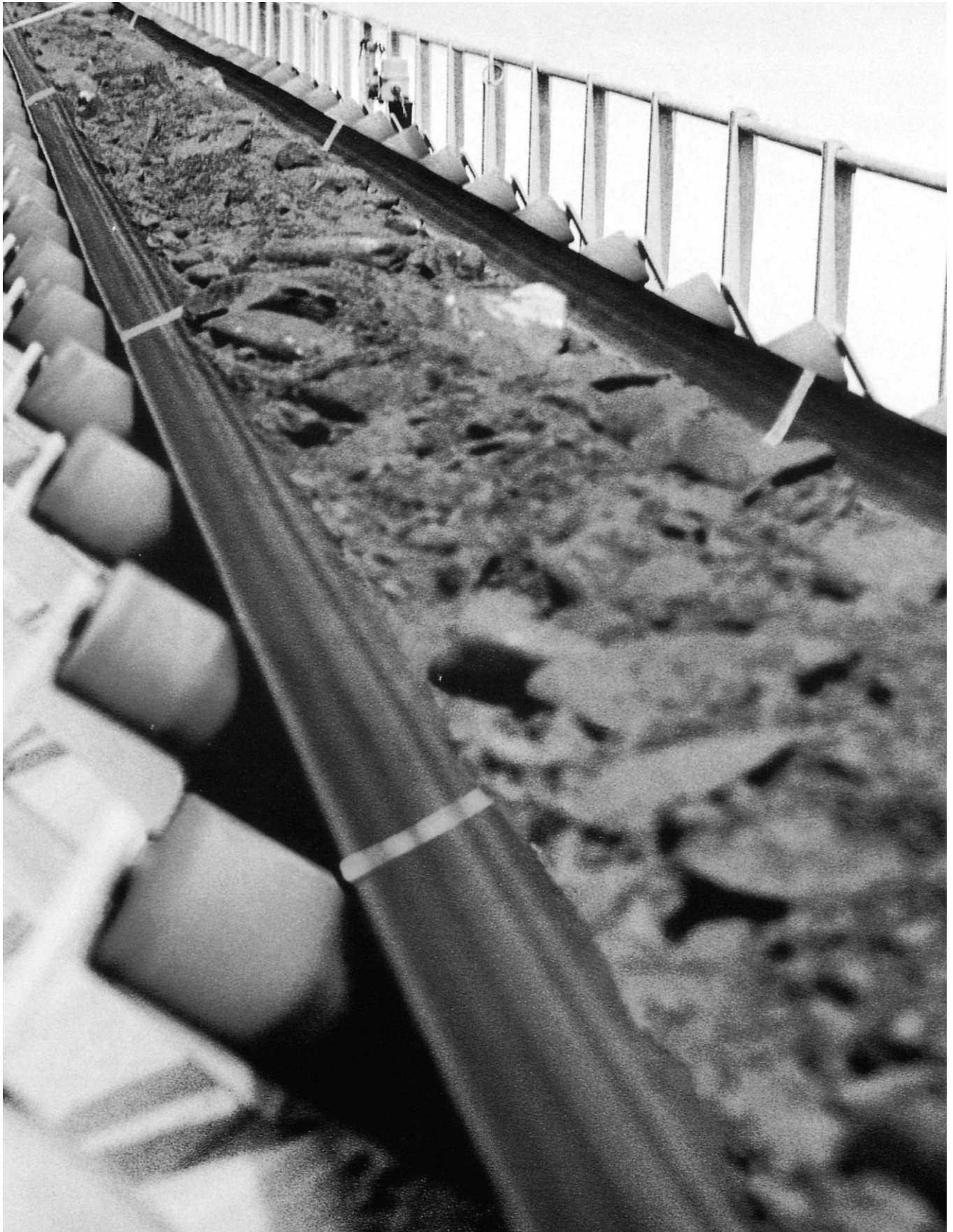

CONTENTS

Transporting, Pulling-In and Splicing Conveyor Belts with Textile Plies

	Page
1 Preparing for Installation _____	5
1.1 Packaging for transportation _____	5
1.1.1 Dimensions _____	5
1.1.1.1 Round coils _____	5
1.1.1.2 Spiral and long coils _____	8
1.1.2 Loading and unloading _____	8
1.1.3 Storage _____	8
1.2 Preparation for pulling in the belt _____	8
1.2.1 Jacking up and pulling in the belt _____	8
1.2.2 Pulling in the belt _____	9
1.2.3 Selecting the vulcanisation site _____	9
1.2.4 Looping up the spliced belt before pulling it in _____	10
1.3 Preparing the work site _____	11
1.3.1 Preparing the work place _____	11
1.3.2 Tightening and clamping the belt _____	11
1.4 Vulcanisation equipment _____	12
1.4.1 Heating plates _____	12
1.4.2 Pressure device _____	12
1.4.3 Accessories _____	12
1.5 Tools _____	13
2 Splicing the fabric belt _____	14
2.1 Non-detachable joins _____	14
2.1.1 How the splice works and demands made on it _____	14
2.1.2 Types of splices _____	15
2.1.2.1 Splicing conveyor belts with more than two plies _____	16
2.1.2.2 Splicing conveyor belts with two plies _____	16
2.1.2.3 Splicing conveyor belts with a single ply _____	17
2.1.3 Aligning the belt ends _____	17
2.1.4 Preparing the belt ends _____	18
2.1.4.1 Normal stepped splices _____	18
2.1.4.2 Splicing 2-ply belts with intermediate ties _____	21
2.1.4.3 Finger splices _____	22
2.1.5 Completing the splice _____	23
2.1.5.1 Setting up the vulcanisation equipment _____	23
2.1.5.2 Vulcanisation _____	24
2.1.6 Splices with special requirements _____	25
2.1.6.1 Splices for short conveyor belts _____	25
2.1.6.2 Splicing conveyer belts with patterned covers _____	25
2.1.7 Splicing materials _____	26
2.2 Detachable splices _____	27
2.2.1 Hook fasteners _____	27
2.2.2 Articulated or hinge fasteners _____	27
Glossary _____	28

Transporting, Pulling-In and Splicing Conveyor Belts with Textile Plies

The tension members in this type of belt are generally two or more textile plies (1) that are joined by layers of a special rubber compound (2). The textile plies are nearly always fabric with different designs. Single, tightly woven fabric plies are also used for special requirements such as underground mining. The core of the belt is generally protected above and below by rubber covers (3) and, if necessary, on the sides by rubber edges (4).

Textile conveyor belts are described in a short form. For example, EP 500/3 identifies a belt with 3 plies of a fabric with polyester threads (E) in the warp direction and polyamide threads (P) in the weft direction with an overall breaking strength of at least 500 N/mm belt width (see DIN 22102, part 1).

Conveyor belts with textile plies generally must be spliced on site, and they are frequently made up of several lengths of belting. The procedures to be used during transportation, pulling into the conveyor (i.e. installation) and splicing are described below.

1. Preparing for Installation

1.1 Packaging for Transportation

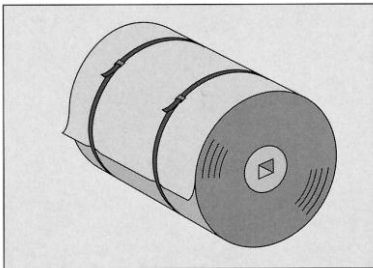

ContiTech conveyor belts are normally wound on wood cores for transportation. Steel cores are only used for special conditions or as reusable cores.

Depending on the size of the drum and the belt weight, it is common to make use of winding cores with an outer diameter of 400 mm to 600 mm and - lengthways through their centre - a square bore to receive the drum shaft.

Normally, belts are shipped on drums without side flanges. Flanged drums are occasionally used for overseas shipments if the belt edge on the drum needs special protection, or if the rolled belt needs to be prevented from slipping.

To protect the belt edges and the covers against sunlight, the belt drum can be wrapped in foil. Protection can be provided against other types of in-transit damage by completely boarding up the flanged drum.

1.1.1 Dimensions

1.1.1.1 Round Coils

For long conveyors the belt is divided into sections. To minimize the number of splices, an attempt is made to keep the sections as long as practicable.

The gross weight of the drum and/or its dimensions influence the max length. The dimensions are determined by transportation options and the conditions at the installation site.

In the following graphs, the drum diameter for conveyor belts is determined by the figures for the:

- Drum core diameter
- Belt thickness
- Belt length

Belt drum diameters with a core that has a 400 mm diameter

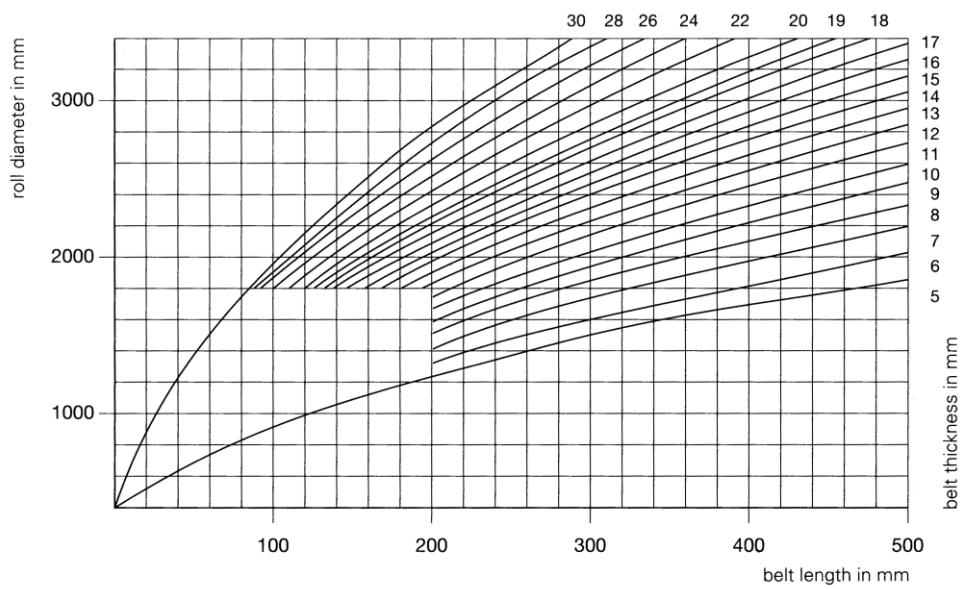
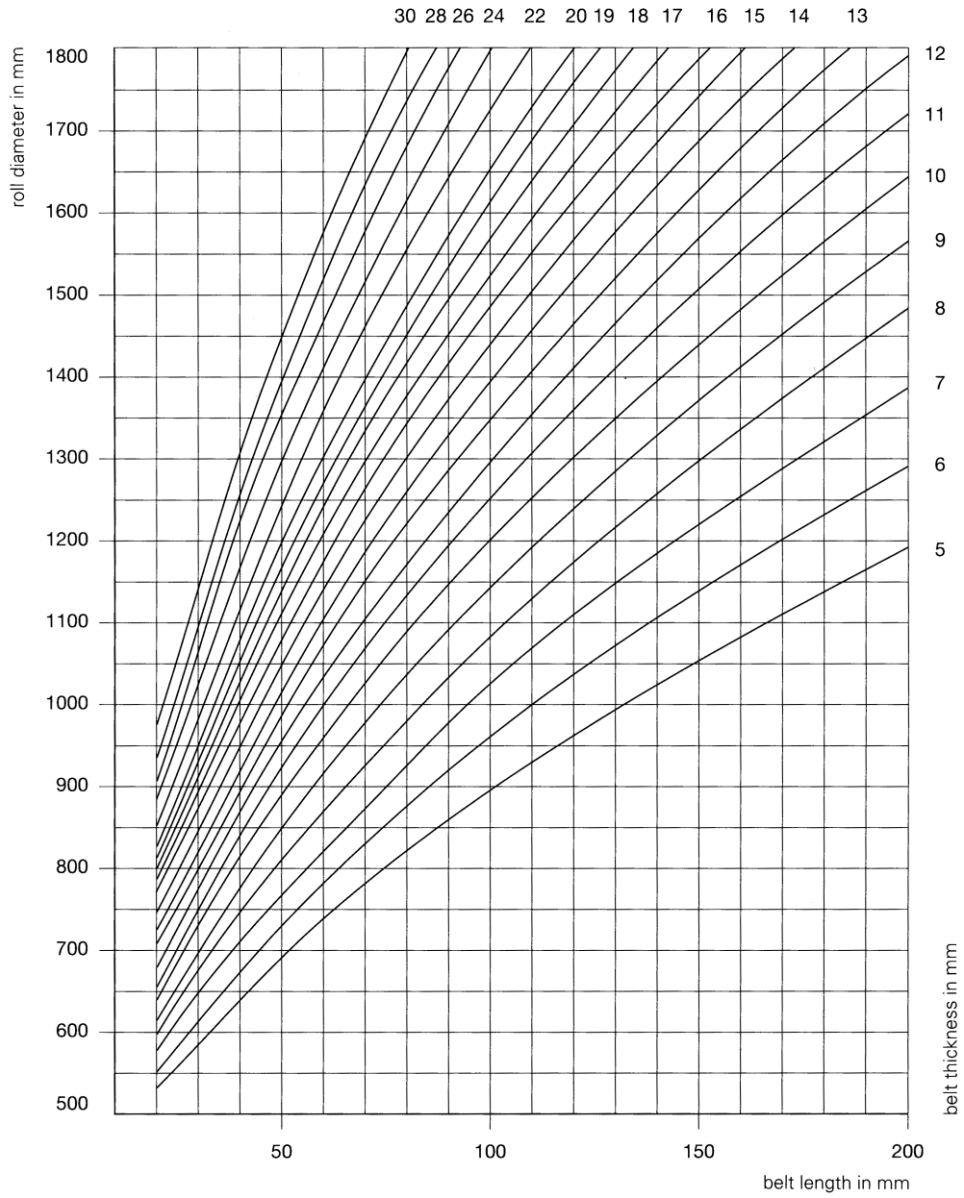

Belt drum diameters with a core that has a 600 mm diameter

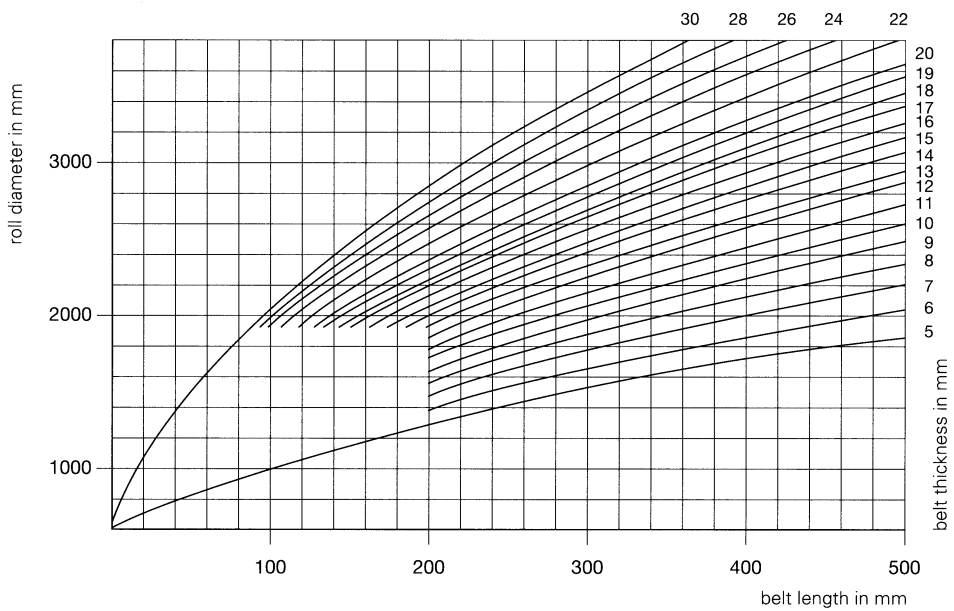
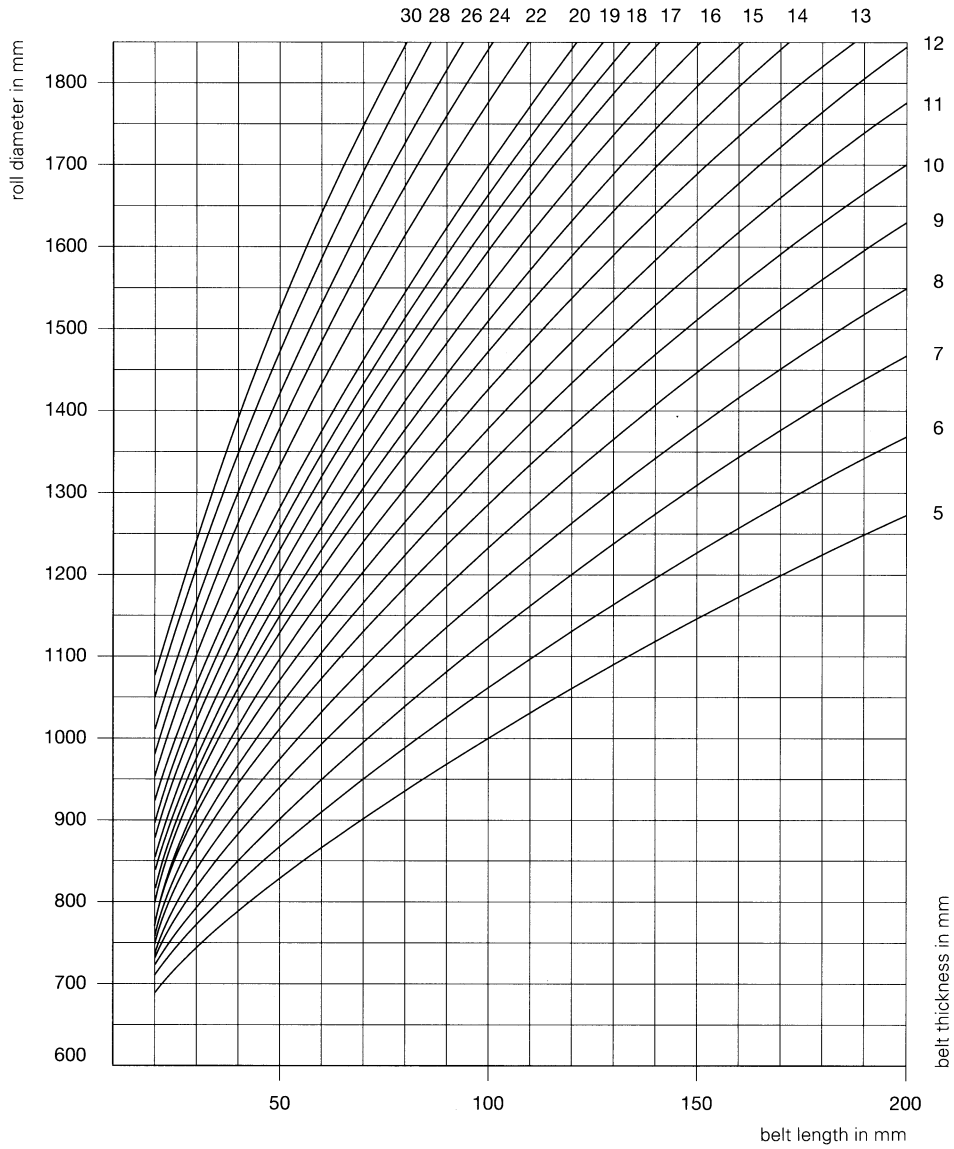

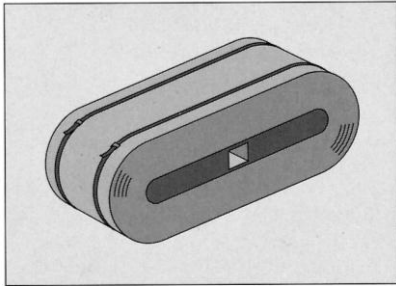
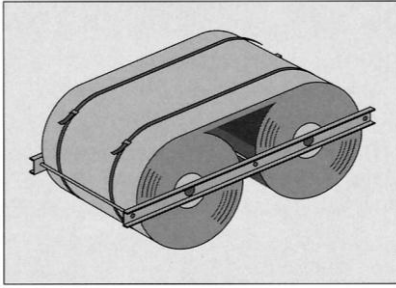

1.1.1.2 Spiral and Long Coils

Special types of drums are spiral and long coils on which long sections can be housed with a smaller diameter.

Spiral and long coils are primarily selected for transporting belts underground.

In the case of spiral coils, the belt rolls are wound against each other. Both rolls are connected by braces on the sides to produce a stable unit for transportation.

1.1.2 Loading and Unloading

When loading and unloading belt rolls, care must be taken to ensure that the belt edges and covers are not damaged. For example, sharp-edged forks of forklifts can be padded with conveyor belt scrap. The same holds true for transporting rolls with cranes and wire cables. The belt edges for example are protected by boards. Spacer bars need to be placed between the two cables when the belt rolls are particularly heavy.

If a belt coil needs to be rolled on the ground, make sure that it is rolled against the winding direction. Otherwise the coil can loosen (danger of telescoping). Place boards underneath when rolling the drum along any ground with sharp-edged objects.

1.1.3 Storage

Belt need to be stored protected from heat, sunlight and mechanical damage. Avoid contact with chemicals, oils or greases to prevent premature ageing, cracking, hardening or swelling (DIN 7716 rubber products, guidelines for storage, servicing and cleaning).

1.2 Procedure for Pulling in the Belt

The schedule for installing the belt, the required personnel and auxiliary equipment and the assignment of responsibilities are established in a preliminary installation meeting.

The position for jacking up the belt coil, the procedure for pulling in the belt and the vulcanization site are determined. Safety takes priority when laying down the pulling-in procedure.

1.2.1 Jacking up and Pulling in the Belt

The way in which the belt is pulled in is determined by the local conditions. The let-off stands and the paths for the rolls need to be suitable for the belt weights and roll diameters. When the belt rolls are light, cable drum jacks with corresponding bearing capacity are sufficient to jack up the belt.

If the belt is delivered as a spiral coil, the double roll must be rewound into a single roll before the belt is pulled in.

The belt roll must be aligned with the axis of the conveyer and be centred in front, behind or even above the belt to be pulled in. If the belt can only be fed from the side, this should be done at an acute angle to the conveyer. The belt may not flop over or become damaged at the edges. To protect the belt, it is helpful to place a few deflector and fender rollers between the let-off point and where the belt enters the conveyer.

1.2.2 Pulling in the Belt

Whereas narrow and short belt sections can be pulled in with a cable tensioner, longer, heavier belts require motor-operated cable winches, or the cables are attached to appropriate towing machines such as a truck or caterpillar.

Before pulling in the belt, make sure that the bottom of the belt is facing the support idlers of the carrying run.

The beginning of the belt needs to be prepared in the following way before being drawn in.

- If the belts are heavy, a drawbar is attached to the beginning of the belt to allow it to be joined to the traction cable. This drawbar consists of two metal plates or flat iron bars with a number of holes. The belt end is provided with matching holes, and it is clamped between the two parts of the drawbar with sufficiently large machine bolts.
- The two belt corners of the front belt end are cut back at an angle or elevated so that they do not hit the trough idlers when pulled in.

If the cable cannot be pulled in the direction of the conveyor run, the cable can be pulled from the side via hinged idlers or deflection idlers. These idlers are attached so that the conveyor frame cannot get twisted or otherwise damaged.

Special safety precautions must be taken when drawing in or unrolling a belt in a conveyor that slopes up or down. If the cable should break or the brake should fail, it would be impossible to stop the falling belt and it could cause substantial damage to its surroundings and be damaged itself. This risk can be reduced by installing a capture device (such as an eccentric trap). We recommend consultation with our installer.

1.2.3 Selecting the Vulcanization Site

For long belt conveyors with a number of belt sections, there are various options for selecting the vulcanization site. If the local conditions allow you to set up a good work area near the supporting frame, this option is preferable. In this case, it is convenient to set up the vulcanization site approximately one section length away from the end drum. After one length has been pulled in, the let-off stand is empty, and a new roll can be mounted while splicing the belt. All splices can be made at one site.

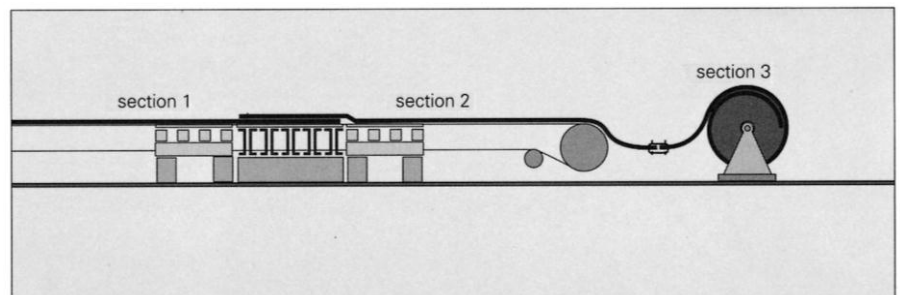

The process is as follows:

Section 1 is pulled in, and the end of this section is temporarily connected to the beginning of section 2 with a flat bar clip. After section 1 has been fed to the working site, the beginning of section 3 can also be joined with a clip to belt end 2 and pulled in. If two vulcanizers are available, you can select the first vulcanization site and then set up a second vulcanization site between the let-off stand and conveyor head so that two splices can be made simultaneously.

If the conditions near the supporting frame are so poor that the quality of the splices might suffer at this location, it is preferable for the vulcanization site to be set up between the drum and the let-off stand.

The first section is pulled into the conveyor, and the end of this section is spliced to the beginning of the belt of the supported second section. While vulcanizing, the drawbar can be pulled so that both sections can be drawn in further afterwards. All the splices, except for the final splice, can be made at this workplace.

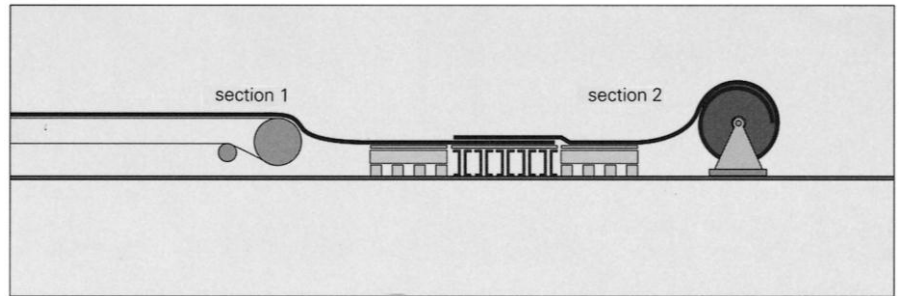

1.2.4 Looping up the belt before pulling in

If the conveying system to be fitted out is in operation, the belt being stopped for a limited time only for replacement purposes, it is possible to splice the part lengths supplied before they are pulled into the conveying system.

When this method is used, you will need a large work area either behind, below or directly next to the belt conveyor.

The vulcanization site is set up directly next to the let-off stand. The first section is unwound from the drum, and laid down in overlapping loops between the vulcanization site and belt conveyor. The belt can be looped in this manner using a vehicle crane or a winch. The sections are spliced at the work site, with the exception of the final splice. After each section is vulcanized, the belt is stacked back and forth in loops. Providing support at the ends of the loops prevents them from kinking. As needed, the loop stack can be set up next to the belt conveyor and fed from the side as described under 1.2.1. After the belt is pulled in, the final splice is made after setting up the vulcanizer on the conveyor.

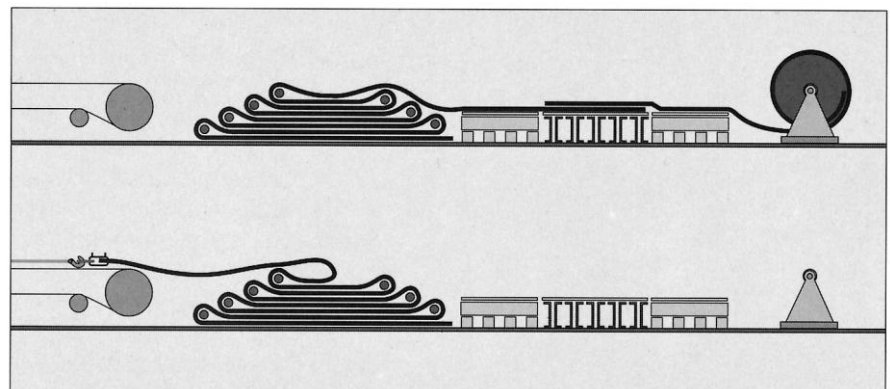

1.3 Preparing the Work Site

To make proper splices, the work site must be set up properly, the vulcanization equipment must be operating correctly, and the right tools must be used.

1.3.1 Preparing the Workplace

To splice the sections of conveyor belts, the workplace must be at least three times as long as the splice length. In front of and following the bottom part of the vulcanization press, worktables of a suitable length are to be set up for precisely aligning and working on the belt ends.

If splice working area is within the conveyor system, either the appropriate length of the belt frames are disassembled and the working surface for splicing the sections is set up on the ground, or the idler assemblies in the carrying run are removed, and the working surface is erected on side structures. A vulcanization press is not used for cold splicing.

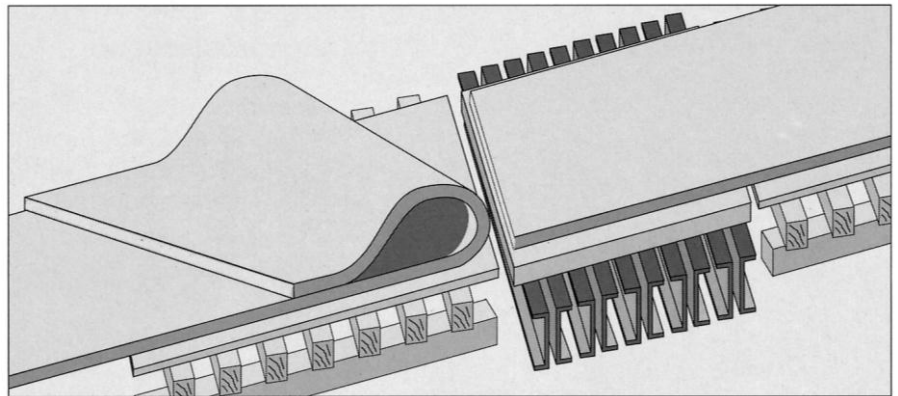

1.3.2 Tightening and Clamping the Belt

The take-up pulley is generally set to the smallest inner circumference since slack is available after removing the vulcanization equipment and opening the belt tensioner.

If the tightening path is long enough and there is enough belt length, the take-up pulley does not have to be set at its end position. This allows sufficient length for at least one additional splice in the take-up. This means faulty splices can be repaired without having to insert a replacement section. It also has the advantage that an idler can be removed without having to cut the belt.

To prepare for the final splice, both belt ends are drawn together, i.e. the belt is tightened to reduce the sag between the idlers to a minimum. The tightening and clamping method - depending on the length of the conveyor and the force required to hold the belt - are very different. The clamps that can be used range from simple wood planks to hydraulic crossbars. Two pairs of crossbars are required.

When a replacement section is inserted, make sure that the two splices containing it are at least 5 m apart.

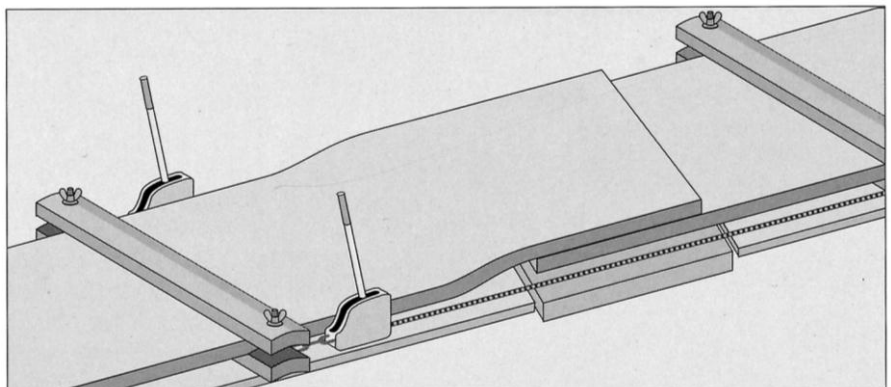

1.4 Vulcanization Equipment

Splices and repairs are made at the installation site with portable vulcanization equipment. The required temperatures and pressure must be maintained over the entire vulcanization area for the belt to be properly vulcanized.

1.4.1 Heating Plates

The vulcanization temperature is attained by electrically heated plates that are made of aluminum to save weight. The temperature can be controlled with a thermostat or PTC thermistor. The heating plates must be designed so that the temperature is evenly distributed over the entire surface that is to be vulcanized. The surface area can be heated by placing together several heating plates in a lengthwise and crosswise direction. The heating plates should extend over the splice area in the lengthwise direction of the belt by approximately 100 mm.

To ensure sufficient vulcanization of the edges and hold the side shims in place, the plates should extend at least 50 mm over the side, that is:

Width of the heating surface = belt width + 100 mm

The angle of the heating plates is normally 16° 40' (i.e. equivalent to 0.3 x belt width).

When belts are installed for underground coal mines, make sure that only permissible firedamp-proof heating plates are used.

1.4.2 Pressure Devise

The pressure required to vulcanize the belt splices can be applied with cross-bars with tightening bolts mechanically, hydraulically or hydro mechanically. The pressure must be evenly distributed over the entire surface to be spliced. Aluminum crossbar pairs are preferable because they are easier to handle.

The specific surface pressure for light conveyor belts should be at least 6 daN/cm² and 10 daN/cm² for heavy belts.

1.4.3 Accessoires

Side shims (side irons) are used with vulcanization equipment to hold the side of the splice. These shims consist of approx. 60 mm-wide flat metal bars. The shims must be approximately 0.5 mm thinner than the belt so that the full amount of pressure can be applied to the splice area.

Another important accessory are panels used for heating. When the heating surface consists of several pairs of heating plates, the panels are placed between the heating plates and belt. Steel panels approximately 1.5 mm thick or aluminum panels approximately 3 mm thick are used.

The dimensions of the panels should be selected so that the sides correspond with the edges of the heating plates and project approximately 100 mm in the lengthwise direction of the belt.

1.5 Tools

To splice belt ends, the following tools are required.

1. Pressure roller
2. Wire brush (rotating)
3. Right-angle grinder and disk grinder
4. Draw vice or hand vice
5. Rubber mallet
6. Hammer
7. Whisk broom
8. Lift and grip pliers
9. Nippers
10. Chalk
11. Ply separator
12. Ply measuring device
13. Pricker
14. Pricking roller
15. Paint brush
16. Saddler's knife
17. Shoemaker's knife with replacement blades
18. Protractor
19. Saddler's pliers
20. Scissors
21. Snap line
22. Gloves
23. C-clamps
24. Tool bag
25. Whetstone
26. Toothed roller
27. Folding yardstick
28. Measuring tape
29. Protective glasses
30. Circular knife/keyhole saw

2. Splicing the Fabric Belt

A distinction is made between detachable and non-detachable joins. The non-detachable joins (splices) can take more stress than detachable joins. All joins, however, are weak links in a conveyor belt. Detachable joins are frequently used in certain industries such as mining, or on machines whenever a non-detachable splice is not justified due to the large amount of time and expense involved. This is the case when the belt frequently has to be shortened or lengthened or when downtime would be costly.

2.1 Non-detachable Joins

A difference is made between vulcanized splices and cold splices. The techniques for manufacturing both types of splices are identical up to a certain point. In this brochure, the vulcanized splice is described in detail. The features of the cold splice are found in the ContiTech brochure, "Kaltverbindung von Gewebegurten mit dem Kontakklebstoff CONTI SECUR[®]" (Cold Splice of Fabric Belts with the Contact Adhesive CONTI SECUR[®]).

2.1.1 How the Splice Works and Demands Made On It

The basis for creating a splice is strong adhesion between the textile layers and the surrounding rubber. At the connecting interface, the layers of the two belt ends are overlapped as prescribed. For a vulcanized splice, the ends are embedded in vulcanizing solution and vulcanized. For cold splices, the function of the rubber cement is assumed by the ContiTech contact adhesive CONTI SECUR[®]. The tension is transferred via the surrounding rubber from the plies of one belt section to the plies of the other belt section. The length of the step is important. The length is adapted to the type of fabric and belt.

In general, the splices have the same thickness and flexural strength as the conveyor belt. If a thick spot cannot be avoided, it may not exceed 3 mm. If scrapers are used to clean the belt, the splice can be damaged if it is more than 3 mm thicker than the rest.

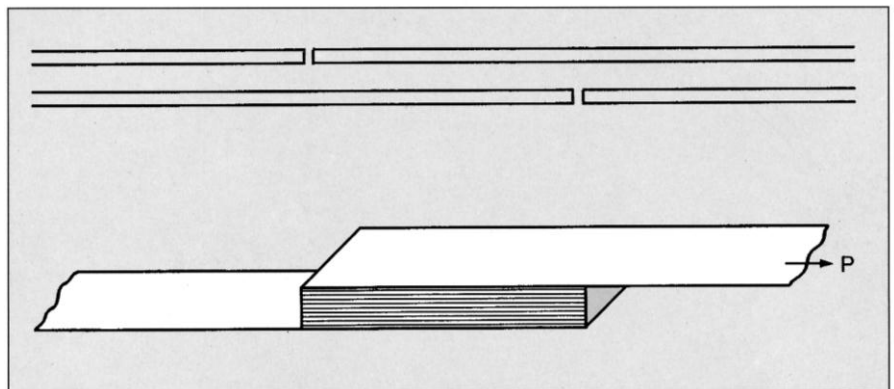

2.1.2 Types of Splices

Splices are standardized for a large number of belt types.

DIN 22121 for belts used in coal mining

Part 1 Conveyor belts with one ply

Part 2 Conveyor belts with two plies

DIN 22102 for belts in general use

Part 3 All type of belts

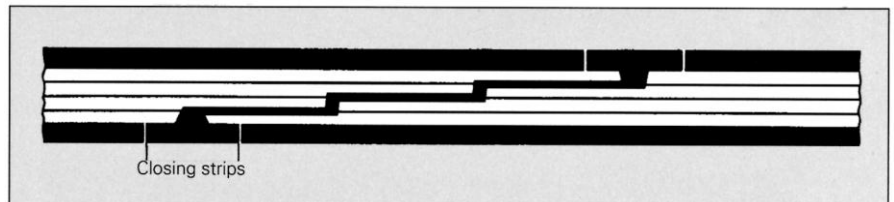

The prescribed dimensions are identical where the two standards describe the splicing of belts with the same construction.

The standards make a distinction between the following three types of splices:

- a) Stepped splice
 - Single step splice
 - Stepped splice with intermediate supports (for belts with two plies with a thick intermediate layer)
- b) Overlapping splice
- c) Finger splice

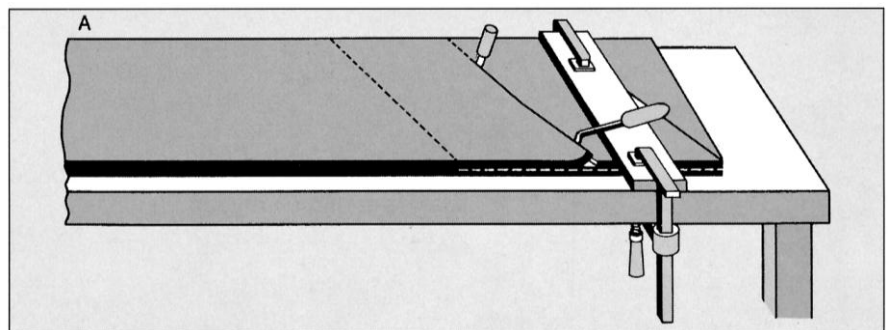

Common to all splices is that parts of one belt end overlap with parts of the other belt end in the splice area. The standard uses the term "**overlapping splice**" but only for those splices where the number of plies in the splice is greater than in the belt itself. Such splices are always thick.

The **finger splice**, that only describes belts with one ply in the standards, is used for very strong belts with two plies.

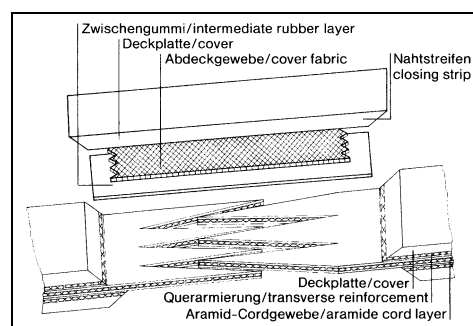

The following have been rejected:

- Overlapping splices (type A DIN 22121, part 2)
- Step splices with intermediate tension member – shortened (type C DIN 22121 part 2)
- Overlapping splice for conveyor belts with one ply (DIN 22102 part 3)
- Overlapping splice for conveyor belts with two plies (DIN 22102 part 3)

These will not be discussed in the following.

Table 1

Minimum step and splice lengths for conveyor belts with more than 2 plies

Belt type	Breaking strength N/mm	Min. step length l_s	Splice length l_c	No. of steps n_s
315/3	80 to 100	150	300	2
400/3	125 to 160	200	40	2
500/3			400	2
630/3			600	3
800/4	200 to 250	250	750	3
1000/5			1000	4
1250/5			1000	4
1600/5	315 to 400	300	1200	4
2000/5				
2500/5	500 to 630	350	1400	4
3150/5				

Table 2

Minimum step and splice lengths for conveyor belts with two plies

Belt type	Min. step length l_s		Splice length l_c	
	1 step	2 step	1 step	2 step
200/2	250	125	250	250
250/2				
315/2	300	150	300	300
400/2				
500/2	350	175	350	350

Table 3

Minimum step and splice lengths for conveyor belts with 2 plies and an intermediate link

Belt type	Min. step length l_s	Splice length l_c
630/2	150	360
800/2	170	400
1000/2	220	500
1250/2	270	600
1600/2	340	740

2.1.2.1 Splices in conveyor belts with more than two plies

The stepped cuts in the fabric produce a loss in strength in these splices calculated as one ply. This means, for example, that a belt with three plies will lose 33% of its strength at the splice, a belt with 4 plies will lose 25%, a belt with 5 plies will lose 20%. (A 50% loss calculated for a belt with two plies is usually not justifiable, so other options have been found in belt construction and splice design - see 2.1.2.2).

For certain belt types, the minimum step length l_s of splice length l_c and the number of steps n_s can be found in Table 1.

With other types of belts listed in Table 1, first the breaking strength of one ply is calculated to determine the splice length l_c . The minimum step length l_s can be found in Table 1. The splice length is then:

$$l_c = l_s (\text{ply number} - 1)$$

Example:

Belt type: 1.000/3

$$\text{Break force of a ply} = \frac{1000}{3} = 333 \text{ N/mm}$$

Step length for this value: 300 mm

$$\text{Splice length: } l_s = 300 \cdot (3 - 1) = 600 \text{ mm}$$

2.1.2.2 Splice on conveyor belts with two plies

Conveyor belts with two plies have two categories:

- Intermediate ply with normal thickness
- Intermediate ply 1 to 2 mm thick

For conventional belt types with normally thick intermediate plies, the minimum step length l_s and splice length l_c can be found in Table 2 for a 1-step splice.

For conventional belt types with thick intermediate layers, the intermediate ply can be removed at the splicing area and be replaced by an intermediate tension member. This provides a splice that is not thicker and has no significant loss of strength. For conventional belt types, the minimum step length l_s and the splice length l_c can be found in Table 3.

Table 4

Minimum step and splice lengths for conveyor belts with one ply link

Belt type	Finger length l_{fin}	Finger width w	Length of covering fabric l_{fab}	No. of steps l_s
630/1	800	60	1100	1300
800/1	1000	60	1300	1500
1000/1	1250	60	1500	1700
1250/1	1500	60	1800	2000
1600/1	2000	70	2300	2500
2000/1	2400	70	2700	2900
2500/1	3000	70	3300	3500
3150/1	3800	70	4100	4300
4000/1	4200	70	4500	4700

2.1.2.3 Splices on conveyor belts with a single ply

The splice of low-strength belts of this type is generally detachable. If permanent splices are to be created, DIN 22102 part 3 provides for two options.

- Overlapping splices for belt types $\leq 500/1$
- Finger splices for belt types $\geq 630/1$

Overlapping splices are easy to make, but contain thick splices, so they can be ignored in practice.

Finger splices are very costly to make and require manual skills. The splices are not thick to the detriment of the cover thickness at the splice area.

Table 4 shows:

- Finger width w
- Finger length l_{fin}
- The length of cover fabric l_{fab}
- The splice length l_s

In general, the following rules apply:

- $l_{fin} = 1,2 \cdot (\text{min. breaking strength of belt})$
- $l_{fab} = l_{fin} + 300$
- $l_s = l_{fin} + 500$

2.1.3 Aligning the Belt Ends

After the workplace has been set up with the supporting crossbars and heating plates and the belt has been pulled into the conveyor, the belt ends are aligned.

For short conveyors, the belt is aligned in the middle over its entire length. In the case of long conveyors, both belt ends are aligned approx. 20 m to 30 m before and after the work site, i.e. placed in the middle of the conveyor. If the work site is directly in front of a deflector or drive idler, it needs to be aligned with this idler.

Both belt ends to be spliced are pulled onto the work surface and their ends are aligned flush.

For wide belts, the middle of the belt is marked at each belt end. This is done for example by marking the middle at three or more points that are more than 1 m apart by measuring from the belt edges, and then snapping a snap line to connect the points. The two marked belt ends are then placed on each other with their edges aligned. Both midlines must be precisely aligned using a guideline.

After the ends are aligned, both belt ends are fixed with crossbars or C-clamps to the end of the worktable so that they cannot shift during subsequent work. However, it must be possible to fold back the belt ends.

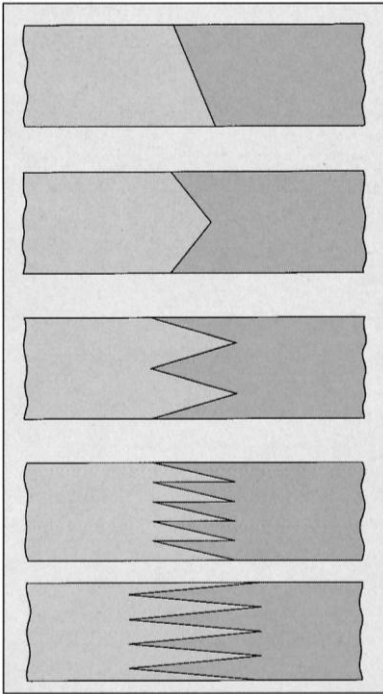

2.1.4 Preparing the Belt Ends

When splicing the ends, follow these basic rules:

- When removing residual rubber on the surface of the fabric, do not damage the fabric.
- Cut butt ends at approx. 30° to provide more adhesive surfaces.
- Roughen interfaces between the covers and rubber edges.
- Spread rubber cement solutions sparingly. They only serve to improve the adhesiveness while assembling and actually can harm the bond after vulcanization.

2.1.4.1 Normal Stepped Splices

Cutting the Belt Ends

Before beginning work, the type of fabric joins must be chosen.

Join Angles

Fabric joins are always cut at an angle. The angled join prevents the join from being stressed over the entire width of the belt when it bends around pulleys and idlers. The greater the angle, the less the stress on the joint, and the longer the splice. An angle of 16° 40' has proven to be a satisfactory standard. It is easy to construct with simple tools (0.3 x belt width). The angle is identified as l_a . For a splice length l_s , the required length of belt for the splice is calculated as follows:

$$l_r = l_s + l_a$$

For particularly small pulley diameters, V-cut splices can be used. These splices require a more skilled technique, however.

Step Direction

If the belt is scraped hard when being cleaned, the splice should be made so that the scraper does not scrape "against" the stepped design. It is better when the direction of belt travel goes "with" the stepped design.

The covers are left on the outer fabric and are only removed from the outer fabric joins to later receive the closing strip.

The steps are created in the fabric plies, starting with one belt end while the other end is folded back. A try square is used to draw a 45° angle from both edges. The midline is used as a reference line for wide belts, and the right angle is drawn from there. On the marked belt end, the angle l_a is drawn from a belt edge and marked for example with a snap line.

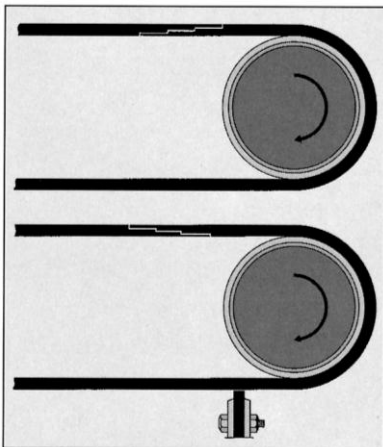

The direction of the angle is determined by the setup of the bottom heating plate.

Cut off the belt end with a shearing knife at an angle. Fold back the belt end and separate the bottom cover to a 30 mm width. If there is a rubber edge in the area of this strip, remove it down to the fabric core. Slightly roughen the cover join edges and interfaces of the rubber edges. Carefully remove any residual rubber from the exposed fabric with a grinding disc or rasp. Fold back the belt end.

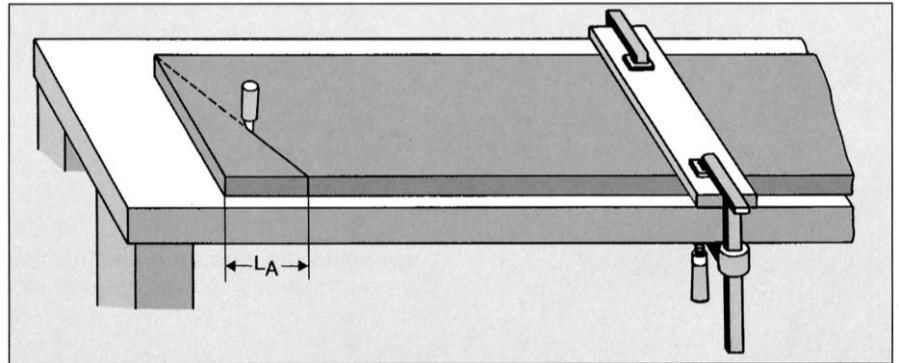

Mark the splicing length l_s (Table 1 or Table 2) on both belt edges and connect them with a line. Draw a second parallel line at distance $l_s + 30$ mm, cut the cover along both lines to the fabric and remove 30 mm wide rubber strips. Separate the top fabric ply with the ply knife along the outer line of the strip. Cut any rubber edge along the fabric so that it is not also removed when the fabric ply is removed.

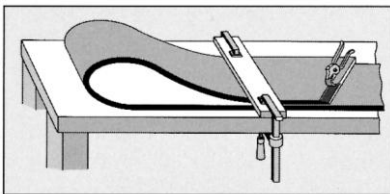

After removing the 30 mm wide cover strip on the carrying side, the individual fabric steps (Table 1 or Table 2) are drawn on the edges.

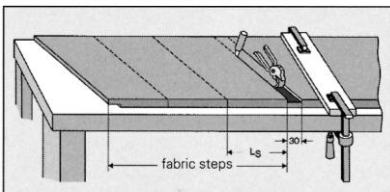

The following operations to remove the fabric plies in steps depend on the available tools:

- Clamp and winch: Method A
- Pliers and muscular force: Method B

Method A

An approx. 20 mm wide cover strip is removed at the angled joins, and the join angle is drawn on the fabric.

The first fabric ply is cut with the ply knife at the first join angle, the first and second fabric plies are cut at the second join angle, etc.

After the corner with the acute angle is removed and held with a clamp, the cut fabric plies and the cover are removed one by one with a pulling device.

Make sure that the intermediate rubber layer has been cut so that it is removed with the fabric.

Any rubber edges are cut down to the plane of the respective fabric ply.

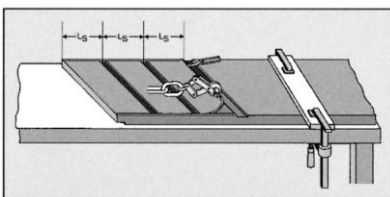

Method B

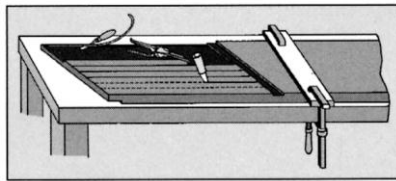
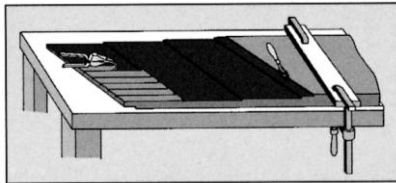
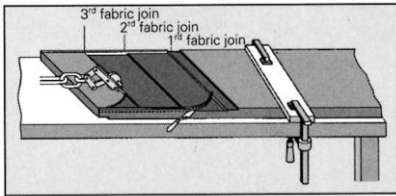

The adhesive force is too great to allow the plies to be removed in the above manner without the above-described tools. The cover and 1st fabric ply are therefore cut in a lengthwise direction to make them easier to remove. The plies are separated at a corner with a ply knife and removed. The strips are firmly held with pliers or a hand vice and pulled off. At the end of this operation, cut the rubber edges to the plane of the second fabric ply.

Lines are drawn on the fabric that is removed in the same manner for the additional join steps. When the lengthwise strips are pulled off, make sure that the rubber layers between the fabric layers are also removed. Any remaining rubber is carefully removed with a grinding wheel or emery cloth.

Note: Ensure the fabric is not damaged during these operations.

After roughening the rubber interfaces and carefully removing the coarse dust, the belt end is ready.

Up to this point, the preparations are the same as for making a cold splice.

The second belt end is then folded over to the prepared first end, aligned and marked. Then this end is prepared in the same way.

Making the Splice

For every splicing procedure, the following holds true:

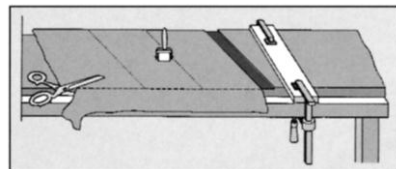
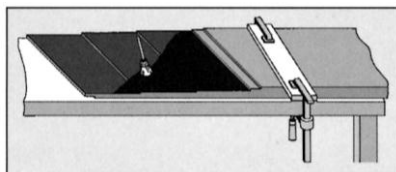

If the tackness is insufficient, a vulcanising solution must be spread thinly. Before splicing, the solvent must have evaporated since trapped solvent can cause bubbles during vulcanisation.

The 0.3 mm to 0.5 mm thick intermediate rubber plate is unrolled. Any soiling is washed off with cleaning spirit. After all the solvent has evaporated, the intermediate rubber plate is placed on the belt end, starting at the closing strip. Any projecting material is cut off, and the plate is pressed onto the fabric steps with a hand roller. Then the film is removed. In the region of the closing strip of the bottom-cover, the fabric is also covered with an intermediate rubber layer before the actual closing strip is inserted.

If the belt has rubber edges, approx. 10 mm wide strips are cut from removed intermediate rubber cover and placed on the edges.

Cover rubber can be used as the splicing material as well. The material for the closing strips is stacked to a sufficient thickness (doubled). 2 strips approx. 16 mm wide are cut for the bottom seam, and a strip approx. 35 mm wide is cut for the top seam, both at sufficient lengths.

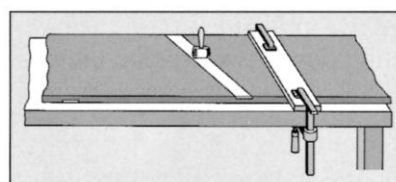
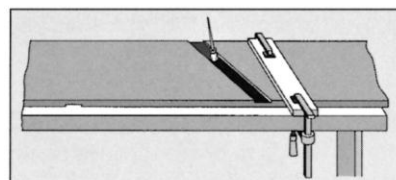

To fill the bottom closing strip groove, a 16 mm wide strip is placed in the closing strip groove of the belt end stepped from the carrying side, and the second 16 mm wide strip is placed in the closing strip groove on the bottom of the other folded-up belt end. The excess strip material (2x16 mm) is necessary to ensure sufficient pressure during vulcanisation. Now both belt ends can be joined. This operation requires a great deal of care since the belt ends must remain aligned and the fabric steps must abut precisely. After joining, the two belt ends are pressed thoroughly by rolling, starting from the middle.

Then the closing strip groove is filled on the carrying side by placing the strips in the groove and tapping them slightly so that the groove edges make an impression in the strips. The closing strip is cut to its final width along the outside of this mark. It is placed in the groove slightly concave (so that no air is trapped) and rolled, working from the middle.

The splice is now ready to be vulcanised.

2.1.4.2 Splicing 2-Ply Belts with Intermediate Fabric

This splice is a special type of step splice. The general rules need to be observed. In the following, the special technique to make this splice will be described.

At the belt end, the angle of bevelling and belt steps are marked (Table 3). Any rubber edges are cut off with a rasp in the middle between the fabric layers.

First, the step furthest away from the belt end is created. A shearing knife cuts through the cover, and the first fabric ply is cut off at a distance l_a from the belt end. A fabric corner is released from the intermediate rubber layer. A clamp is attached to the corner, and the fabric and cover are pulled off with a hoist winch to second line l_s . The intermediate rubber layer should remain on the bottom fabric layer.

The lifted ply is folded back to the splice and clamped with C-clamps. Proceeding from the cut edge, a 30 mm wide cover strip is marked, cut to the fabric and pulled off.

The belt end is cut off at the marked angle line.

After folding back the belt, a 30 mm wide cover strip is marked, cut and pulled off on the backing side.

The belt end is rolled back, and the cover and fabric are pulled off the front step. Then the intermediate rubber layer is removed from the entire splicing surface.

The other belt end is now rolled to the prepared first end and marked. The second belt end is then prepared in the same way.

Both belt ends are now pulled together until the bottom fabric plies precisely face each other. The belt ends are realigned and clamped with C-clamps.

After the top plies of both belt ends are drawn back, the rubberised intermediate ties are inserted. A piece is cut to the width of the fabric core and length l_s and rolled up with the film onto the splice. In the gap between the folded-back fabric steps and the inserted intermediate tie, a narrow strip of rubber approx. 0.5 mm thick is inserted and pressed. The film is removed, and the two top plies of both belt ends are placed on the join and thoroughly rolled.

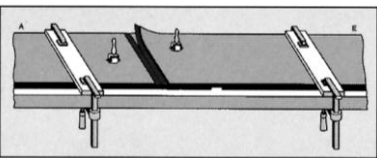
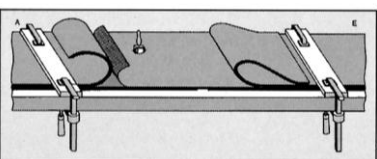
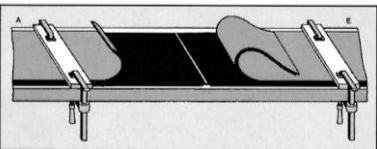
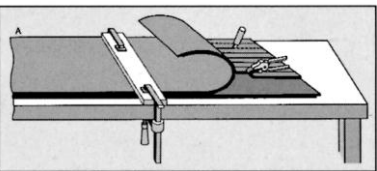
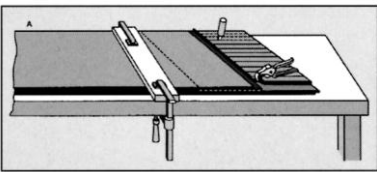
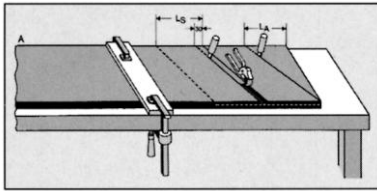
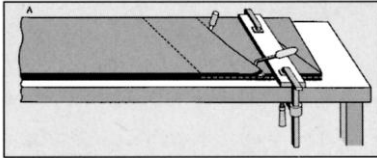
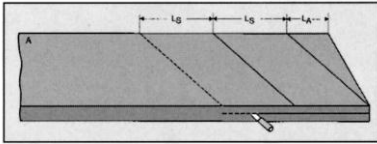

2.1.4.3 Finger Splices

A finger splice is used for very strong conveyor belts with one or two plies. It only performs well if it is completed very carefully. It is very important to have a uniformly thick intermediate rubber layer between the fingers of both belt ends.

Unlike other types of splices on fabric belts, the covers are completely removed in the splice area and are rebuilt.

After the belt parts to be spliced are aligned, they are clamped to the worktable so that the ends can be folded back. On the top belt, the final belt end is marked with a transverse line at a right angle to the belt axis.

When finger splices are used, it is not necessary for the fingertips to run at an angle. They generally do run at an angle, however, to correspond to rhombus-shaped heating plates. The transverse line or a line drawn at an angle to the transverse line becomes a reference line for the following operation. This reference line is marked.

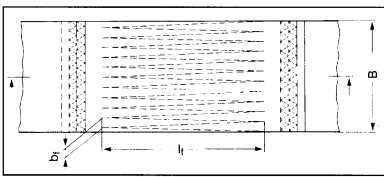

Starting from the reference line, splice length l_s (Table 4) is marked, and any rubber edges are cut off this area with a shearing knife. On the cover of the top belt piece, the zone of the finger with length l_f (Table 4) is marked by two lines parallel to the reference line. Between these lines, the individual fingers are drawn with finger width w_f (Table 4). Make sure that the finger width at the edges is at least $w_f/2$. The width of the fingers between them approximates the desired width w_f . If many splices of this kind are to be made, it is recommendable to prepare a template to draw the finger pattern.

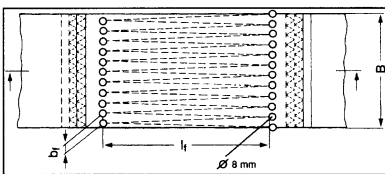

The two belt ends are realigned and prevented from moving by being held in C-clamps. Holes 8 mm in diameter are drilled at the base corners of the fingers through both belt ends. They serve as target points for the cut lines. This helps the matching of the finger patterns of the two belt ends.

The fingers are marked and cut out. This requires a great amount of precision and is best done with a rotating, motor-driven circular knife. A keyhole saw may also be used.

Starting from the reference line, the cut lines are drawn for the cover joins. The cover is cut at a 30° angle to the belt plane to prepare for removing the cover. Starting at the cover joins, the covers are removed on the top and bottom sides.

Both belt ends are then folded back. The heating panels and padding cloth are placed on the heating plates. The bottom cover - whose thickness has been reduced by the thickness of the cover fabric - is cut at a 30° angle on one side, placed at the cover join of the first belt section, marked at the join of the second belt section and then cut. The rubberised bottom cover fabric is placed on top, and any fabric extending over the side is cut off. The provided compensating rubber plates are placed on both ends of the cover fabric. The plates are adapted on one side to the ends of the jaggedly-cut cover fabric. On the other side, they are cut-to-size as needed.

The fingers of one side are rolled onto the bottom plate prepared in this manner. The joint rubber strip approx. 2 mm thick (thickness of the belt core) is placed on the face of the fingers and pressed down firmly. The fingers of the other belt side are pushed against the joint strip. Both fabric ends are carefully rolled on, starting from the middle.

The cover fabric with compensating rubber plates and a top cover is constructed in the same way. If the belt has rubber edges, they are made from cover material at the end.

2.1.5 Completing the Splice

2.1.5.1 Setting up the Vulcanisation Equipment

The entire join area is covered with a padding cloth, as is the bottom side of the splice.

Thin fabric or shirting strips approx. 100 mm wide are placed in steps at the cover splices to increase vulcanisation pressure and reduce the thickness in this transition area.

Shims or edge bars, that are approx. 0.5 mm thinner than the belt thickness, are placed along both ends of the belt.

As described under 1.4 in reference to the bottom side, heating panels are placed over the entire splice surface. Then the top heating plates are laid on flush with the edges of the bottom plates. When several plate pairs are used, the plate joins should be offset.

The top crossbars are mounted precisely aligned with the bottom cross bars. Make sure that a plate pair is centred over the cover joins and over plate aggregates.

Tie bolts are inserted in the ends of the press bars and slightly tightened so that the edge bars can be wedged by the hydraulic pressure bars.

The prescribed pressure is applied evenly. The join is now ready to be vulcanised.

If other vulcanisation devices are used, such as ones with hydro mechanical pressure systems, follow the instructions of their manufacturer.

2.1.5.2 Vulcanisation

Either electrically operated heating plates (with thermostatically-controlled heating elements), or heating elements with a self-regulating heating system are used to vulcanise splices.

Table 5

Recommend heating time in relation to belt thickness

Belt thickness mm	Heating time in minutes
10-14	25
15-17	35
18-21	40
22-24	50
25-29	55
30-34	65
35-40	75
41-50	95

The average vulcanisation temperature is 145 °C. This temperature must be uniformly maintained over the entire splice surface and needs to be monitored by a plug-in thermometer or electrical temperature sensor over the entire heating time. When the conveyor belt is installed in the open air, strong temperature fluctuations e.g. caused by a side wind are to be prevented by setting up a weather-protected tent or a tarpaulin shelter.

The heating time depends on the belt thickness. Our recommendations are in Table 5.

The heating time starts as soon as the heating-plate temperature has reached 140 °C. It ends when the device is turned off.

For special rubber compounds that are used in mining (fire-resistant belts) or in the iron and steel industry (hot-materials belts), please contact us for our recommendations concerning the heating temperature and heating time.

The set pressure must be maintained throughout the heating period.

After the heating time has expired, we recommend that the splice be cooled under pressure to about 80 °C. Then the vulcanisation equipment can be disassembled. Opening the tent or blowing compressed air onto the heating device can shorten the cooling time.

After the padding cloth is removed, any edges that have pressed outward are cut off, and any raised areas at the closing strips or transitions are carefully abraded.

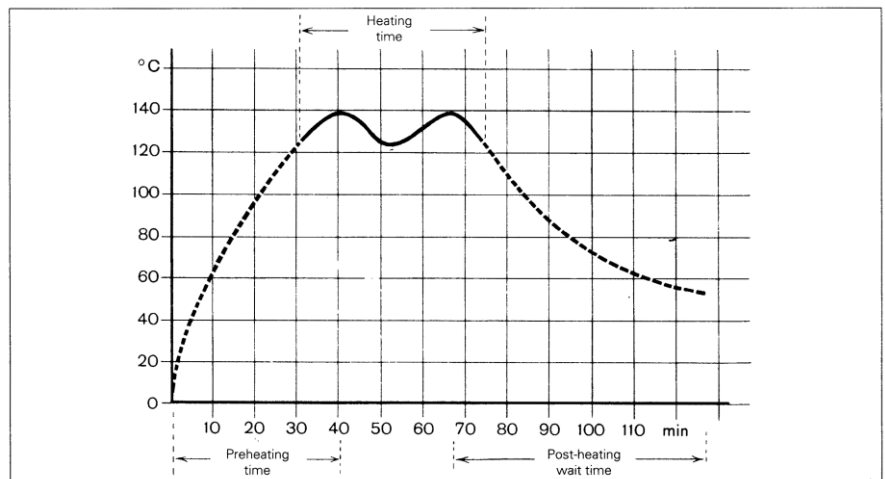

2.1.6 Splices with Special Requirements

2.1.6.1 Splices for Short Conveyor Belts

The precise length does not have to be determined for long conveyor belts that are spliced to form an endless loop on the conveyor system. This is not the case for short conveyor belts that are spliced to form an endless belt separate from the conveyor system and then placed on the system. They must be spliced to a specified inner length, usually in a workshop.

The required length is usually the inner perimeter such as the length measured by running a measuring tape around the pulleys. The stretched length is greater by approx. 3x the belt thickness. The cut belt length is determined as follows:

Endless inner length + overlap l_0 + 3x belt thickness.

2.1.6.2 Joining Conveyor Belts with Patterned Covers

For inclined conveying, every belt has a threshold angle at which the conveyed material starts to slide down the belt. By making a patterned cover, this threshold angle can be increased. However, such cover designs are particularly problematic when vulcanising splices. Two types of splices are relevant in this regard:

- Belts with fine cover patterns
- Belts with chevron cleats

Belts with Fine Cover Patterns

The problem is to keep the fine patterns at the splice. This is done by not removing a strip to receive a closing strip. On the contrary, a section of cover rubber is left to project over the end of the fabric. When the splice is made, the covers of both belt sections are cut facing each other so that a narrow gap approx. 2 mm wide remains. This gap is filled with rubber.

The trick during vulcanisation is to prevent the patterns from being flattened by the hotplates. We recommend two methods to prevent this happening:

1. Place a felt cloth approx. 5 mm thick directly on the splice surface.
2. Cover the splice with shirting and cover this with a layer of slightly moist sand approx. 10 mm thick.

Then put on the heating plate and heating panels.

Since there is a high likelihood that some settling will occur for both methods, the pressure must be adjusted during vulcanisation.

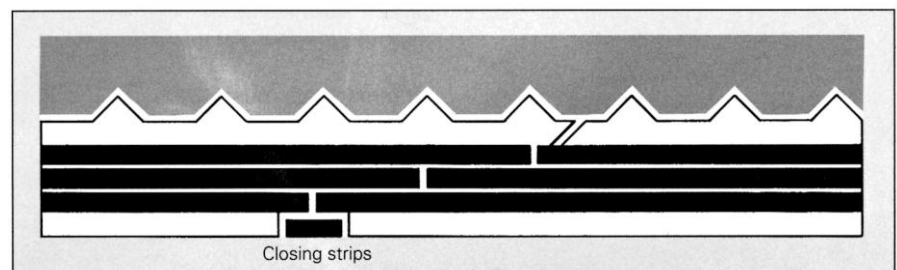

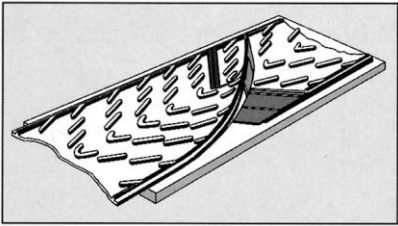
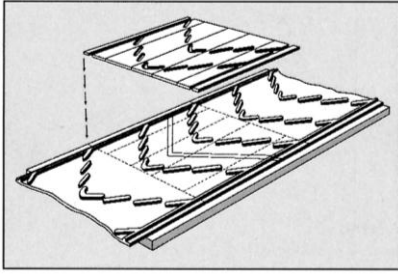

Belts with Chevron Cleats

Since the cleats are arranged as arrows, the joints must be cut in an arrow shape below 45°. The cleat rows are divided into 190 mm sections. This determines the step length; it must be either 190 mm or a multiple thereof. The joints are made as described under 2.1.2.1 and 2.1.2.2 taking this into consideration. Make sure that the cleat distribution at the joint is precisely maintained.

Since the cleats are 15 mm high, the methods used for fine patterns cannot be used. To give the joint enough pressure between the cleats during vulcanisation, templates must be applied at the joint. These can be made of metal or wood. A makeshift template can be made by cutting out the cleats from a scrap piece of the chevron-cleat belt. The templates must be approx. 0.5 mm thinner than the cleat height so that the joint can also receive pressure under the cleats.

If belts with chevron cleats of different widths have to be spliced, it is recommendable to procure metal templates that can be adjusted for different widths.

2.1.7 Splicing Materials

The following materials are required to make conveyor belt splices.

For stepped splices in:

Belts with more than two plies

Belts with two plies without an intermediate tie

- Rubber insert
- Cover rubber for closing strips
- Installation solution

Belts with two plies with an intermediate tie

- Rubber insert
- Rubberised intermediate tie
- Cover rubber for closing strips
- Installation solution

For finger splices in:

Belts with one or two plies

- Rubberised cover fabric
- Cover rubber for the top and bottom
- Installation solution

The quality and size of the splicing material needs to be suitable for the respective conveyor belt. The materials can be procured either as complete splicing sets or in rolls corresponding to the size of the splice and belt width.

Storage times: All raw rubber compounds cannot be stored for very long. We guarantee a minimum shelf life of six months after manufacture, with the proviso that the following conditions are observed:

The materials must be stored in original packaging, i.e. wrapped in film or in sealed sheet metal containers (for solutions). The material needs to be protected from moisture and direct sunlight. Storage temperature: 15-25 °C.

Storing special rubber compounds in refrigerated storage rooms at approx. +4 °C can clearly extend the storage life.

Solution may only be stored in well-ventilated rooms while observing the legal guidelines for flammable liquids (VbF) and water-polluting substances (WHG).

2.2 Detachable Splices

Detachable belt connections can be made easily and quickly. However, their dynamic strength is less than for non-detachable splices. Nevertheless, the results are always satisfactory when the elements of detachable joins are used for belts whose fabric has been specially developed for this kind of connection. There are different types of connectors on the market:

- Hook fasteners
- Articulated or hinge fasteners

2.2.1 Hook Fasteners

Hook fasteners are made of round wire with polished tips. The belt ends are cut at a right angle. The belt width narrows toward the cut edge by approx. 20 mm so that the connection is not damaged if the belt runs to the side.

The hooks consist of several rows of adjacent hooks. The tips of the hooks are open. To press the hooks into the belt end, a special pair of pressing pliers is used. The belt end is clamped tight. The hooks are held straight in a comb and pressed with the two levers of the pressing pliers into the end of the belt, and bent around the base of the hooks after passing through the other side of the belt.

Hooks of a simpler design merely penetrate the fabric and are bent on the other side.

The hooks form a series of eyelets in front of the cut edge of the belt. The series of eyelets of two belt sections can be pushed into each other. If a coupling rod is forced through them, they form a hinge.

There are specific hooks for specific belt thicknesses.

2.2.2 Articulated or Hinge Fasteners

Articulated or hinge fasteners are hinge-like connecting elements stamped out of sheet steel. The belt ends are cut at a right angle. The belt width narrows by approx. 20 mm so that the connection is not damaged when the belt runs to the side. The individual hinge elements are pushed toward the cut edge. Depending on the design, the elements are fixed to the belt end by driving in U-shaped cramps or pointed rivets. The elements of two belt ends mesh like a comb. Both belt sections are connected with a coupling rod.

Glossary	Page
Accessories _____	12
Aligning _____	5,14,15,17,18,19,20
Angled cut _____	5,15,16,19
Belt tensioner _____	8
Cold splice _____	5,11,17
Detachable connection _____	11,14,24
Drawing in _____	8,9
Grasping _____	11
Heating panel _____	9,20,21,22
Heating plates _____	8,9,12,14,16,19,20,22
Heating time _____	12
Installation solution _____	18,20,25
Join lengths _____	8,12,14,15,20
Long rolls _____	8
Looping Up _____	10
Non-detachable join _____	11,14
Padding cloth _____	5,14
Pressure (vulcanisation) _____	5,9,21,22,23
Pressure crossbars _____	20,21,22
Shims _____	8,9,21
Spiral rolls _____	8
Splicing materials _____	24
Storage	
- Belt roll _____	5
- Splicing materials _____	26
Temperature (vulc.) _____	8,22
Tightening _____	11,22
Tightening crossbars _____	8
Tools _____	8,13
Transportation packaging _____	5
Vulcanisation _____	8,18,21,22
Vulcanisation equipment _____	8,9,10,12,21,23
Vulcanisation pressure _____	8,9,21,22,23
Vulcanisation site _____	5
Worksite _____	5,7,11

www.contitech.de/conveyorbelts



Conveyor Belt Group

Contact

ContiTech Transportbandsysteme GmbH
D-37154 Northeim
Phone: +49 5551 702 - 0
transportbandsysteme@cbg.contitech.de

Your local contact:

📍 www.contitech.de/contactlocator

The ContiTech division of the Continental Corporation is a development partner and original equipment supplier to numerous industries for high-quality functional parts, components and systems. With its know-how in rubber and plastics technology, ContiTech contributes significantly to industrial progress and mobility that is safe, comfortable and eco-friendly.

The contents of this publication are the result of extensive research and application engineering experience. All information and comments are provided in good faith on the basis of what is known; they do not vouch for warranted qualities and do not exempt the user from own verification, also with respect to third-party property rights. No liability on whatever legal grounds is assumed for the advice given herein. This does not apply in the event that we or our legal representatives or senior executives can be shown to have acted with wrongful intent or gross negligence. Any liability is excluded for damage due to minor negligence. This disclaimer also covers the personal liability of our legal representatives and employees or other official agents. ©2010 by ContiTech AG, Hannover. All rights reserved.



1976 - 2019

www.juncor.pt

PORTAL B2B:

- Compras online
- Orçamento na hora
- Esclarecimento de dúvidas: Preços e Stocks
- Encomendas
- Licitação
- Descontos
- Eficiência e Segurança

Redes sociais

Facebook: www.facebook.com/juncor

Twitter: www.twitter.com/juncor_sa

LinkedIn: www.linkedin.com/company/juncor-sa

Instagram: www.instagram.com/juncor_sa

Pinterest: www.pinterest.pt/juncorsa

Canal Youtube: www.youtube.com/juncoraccess

“Adicionamos movimento ao seu negócio!”