

Chumaceiras

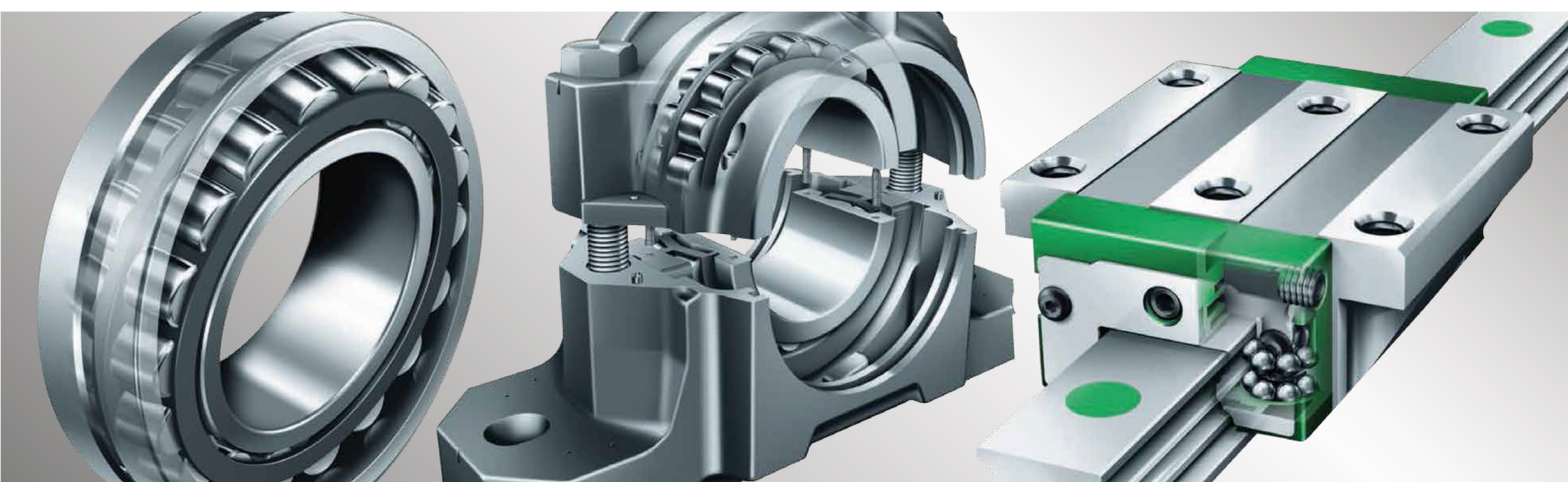

PRODUTO - SERVIÇO - ENGENHARIA - CONSULTORIA



COMPANY WITH
QUALITY SYSTEM
CERTIFIED BY DNV GL
= ISO 9001 =

SUPPORTI AUTOALLINEANTI SELF-ALIGNING BEARING UNITS



CATALOGO TECNICO GENERALE
GENERAL TECHNICAL CATALOGUE

01.01.18

www.isb-bearing.com



Supporti autoallineanti

Self-aligning bearing units



**DISPONIBILI SUPPORTI PER ALTE TEMPERATURE
HIGH TEMPERATURES BEARING UNITS AVAILABLE**

Supporti INOX

Stainless steel bearing units



Supporti in plastica

Plastic bearing units



■ SEDE PRINCIPALE
HEAD OFFICE



■ MAGAZZINO
WAREHOUSE

■ UFFICIO COMMERCIALE
SALES DEPARTMENT

 **ITALCUSCINETTI** S.p.A.
forniture industriali
industrial supplies

 CERTIFICAZIONE DI SISTEMA QUALITÀ
DNV-GL
ISO 9001

ISB Bearing China (Shanghai) Co., Ltd.

ISB Bearing India Pvt. Ltd.

ITALCUSCINETTI S.p.A. a Socio Unico - C.F. e P.I. CEE IT 00966080350
Via Caponnetto, 15 - 42048 Rubiera (Reggio Emilia) ITALIA
ITALIA Tel. +39 0522 621811 - comm.italcuscinetti.it
EXPORT Tel. +39 0522 621830 - export@italcuscinetti.it
R.E.A. C.C.I.A.A. RE 153325 - Capitale Sociale € 1.000.000 i.v.
info@italcuscinetti.it - **www.italcuscinetti.it**

艾斯比轴承上海有限公司 - Building 8 No. 860 Zhongde Road
Dagang Town, Songjiang District - Shanghai 201616 (People's Republic of China)
Tel. 0086 021 5988 5302 - Fax 0086 021 5988 5305 - info@italbearings.cn

Production control - Controllo processo produttivo



INDUSTRIES
BEARINGS & COMPONENTS

www.isb-bearing.com

PROGRAMMA GENERALE DI VENDITA
GENERAL SALES PROGRAM



Cuscinetti e componenti *
*Bearings and components **



ELECTRICAL MOTORS STANDARD

Cuscinetti per applicazioni "bassa rumorosità" *
*Bearings for "low noise" applications **



Cuscinetti di super precisione *
*Super precision bearings **



Cuscinetti a rullini *
*Needle bearings **



Cuscinetti di base *
*Slewing bearings **



Supporti autoallineanti *
*Self-aligning bearing units **



Snodi sferici teste a snodo - forcelle *
*Spherical plain bearings rod ends - clevises **



Boccole *
*Bushes **



Componenti per la movimentazione lineare *
*Components for linear motion **



Ruote libere *
*Free wheels **



Cuscinetti e supporti autoallineanti *
*Bearings and Self-aligning bearing units **

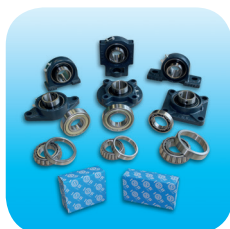

Disponibile grande e completo assortimento di cuscinetti con pronta consegna.

Big and full assortment of bearings with prompt delivery.

Cuscinetti SKF - FAG
SKF - FAG Bearings



* Per ulteriori informazioni, potete richiedere il catalogo tecnico, disponibile anche on line: www.italcuscinetti.it

* For further information, please ask for technical catalogue, also available on line: www.italcuscinetti.it



CATALOGO TECNICO GENERALE
GENERAL TECHNICAL CATALOGUE

Distributore / Distributor



- | | | | |
|----------------|----------------|-------------------------|---------------|
| 1 ALGERIA | 12 BULGARIA | 23 DENMARK | 34 GREECE |
| 2 ANGOLA | 13 CANADA | 24 ECUADOR | 35 INDIA |
| 3 SAUDI ARABIA | 14 CHILE | 25 EGYPT | 36 IRELAND |
| 4 ARGENTINA | 15 CHINA | 26 EL SALVADOR | 37 ICELAND |
| 5 ARMENIA | 16 CYPRUS | 27 UNITED ARAB EMIRATES | 38 ISRAEL |
| 6 AUSTRALIA | 17 COLOMBIA | 28 ESTONIA | 39 ITALY |
| 7 AUSTRIA | 18 SOUTH KOREA | 29 FINLAND | 40 KAZAKHSTAN |
| 8 AZERBAIJAN | 19 IVORY COAST | 30 FRANCE | 41 KENYA |
| 9 BELARUS | 20 COSTA RICA | 31 GERMANY | 42 LATVIA |
| 10 BELGIUM | 21 CROATIA | 32 JAPAN | 43 LEBANON |
| 11 BRAZIL | 22 CUBA | 33 JORDAN | 44 LITHUANIA |

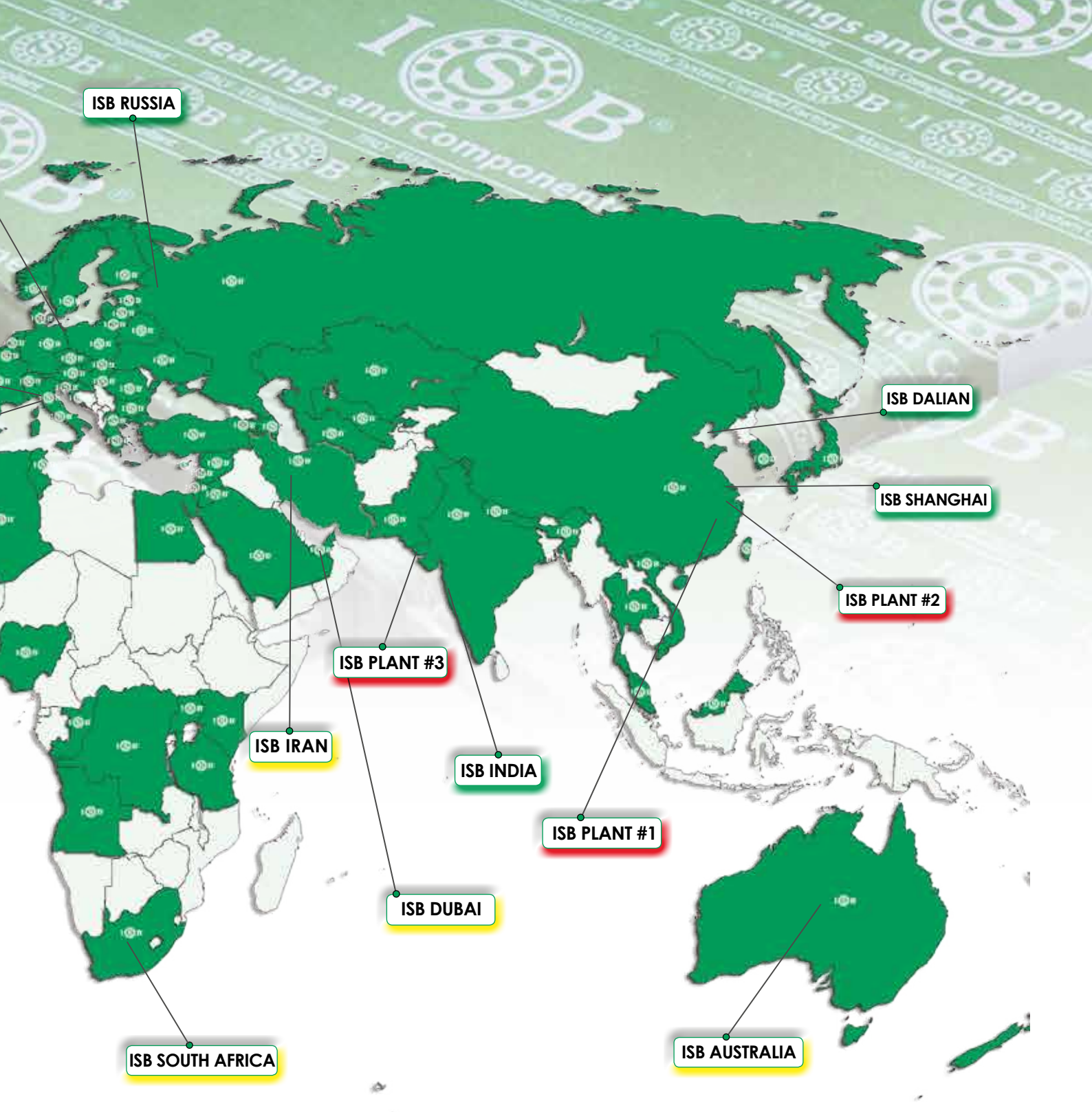

Our presence in the world



-  45 MACEDONIA
-  46 MALAYSIA
-  47 MALTA
-  48 MOROCCO
-  49 MEXICO
-  50 NEPAL
-  51 NICARAGUA
-  52 NIGERIA
-  53 NORWAY
-  54 NEW ZEALAND
-  55 NETHERLANDS

-  56 PANAMA
-  57 PAKISTAN
-  58 PERU
-  59 POLAND
-  60 PORTUGAL
-  61 UNITED KINGDOM
-  62 REPUBLIQUE of the CONGO
-  63 DEM. REP. of the CONGO
-  64 CZECH REPUBLIC
-  65 DOMINICAN REPUBLIC
-  66 SLOVAKIAN REPUBLIC

-  67 RUMANIA
-  68 RUSSIA
-  69 SAN MARINO
-  70 SENEGAL
-  71 SYRIA
-  72 SLOVENIA
-  73 SPAIN
-  74 UNITED STATES of AMERICA
-  75 SOUTH AFRICA
-  76 SWEDEN
-  77 SWITZERLAND

-  78 TAIWAN
-  79 TANZANIA
-  80 THAILANDIA
-  81 TUNISIA
-  82 TURKEY
-  83 TURKMENISTAN
-  84 UKRAINE
-  85 REPUBLIC OF UGANDA
-  86 HUNGARY
-  87 UZBEKISTAN
-  88 VIETNAM
-  89 VENEZUELA

Tutti i prodotti ISB® sono costruiti esclusivamente da aziende con Sistema Qualità certificato secondo le norme UNI EN ISO 9001

All products ISB® are manufactured exclusively by companies with UNI EN ISO 9001 certified Quality System.



**... un'ulteriore serie di controlli vengono eseguiti da Laboratori esterni specializzati, attrezzati con moderni strumenti.
Laboratorio Controllo Qualità.**

**... an additional series of tests are conducted by specialised third party Laboratories using the latest instruments.
Quality Control Laboratory.**



... centro di controllo per la qualità nella nostra sede in ITALIA.

... uno staff di Ingegneri tecnici della Qualità, al vostro servizio.



... a quality control centre is located in our ITALY headquarters.

... our staff of technical engineers at yr service, for Quality.



ISIR N° 0015
Rapporto di controllo di prima campionatura
Initial Sample Inspection Report

DENOMINAZIONE Part name: **Supporto UFL 005**
Fornitore Supplier name: **CF 595**

CODICE ARTICOLO Part number: **31095120**
CODICE FORNITORE Supplier code: **WJBXXITA04-S**

QTA' CONSEGNERATA Delivered quantity: **10**
QTA' CONTROLLATA Inspected quantity: **10**

ISPEZIONATO DA Inspected by: **Quality Control**
DATA Date: **13/09/2010**

DATA Date: **09/09/2010**

I campioni sono generati in accordo con le specifiche tecniche riportate nei cataloghi ISB. The samples are generated in accordance with the specifications reported in technical catalogues.

Caratteristiche controllate Inspected characteristics

Posizione Key	Dimensione nominale Specifiche materiali Nominal dimension Material specification	Unità di misura Unit of measure	Tolleranze Tolerances	Risultati della misurazione Measurement results				
				Articolo 1 Piece	Articolo 2 Piece	Articolo 3 Piece	Articolo 4 Piece	Articolo 5 Piece
1	Bore Ø 25 (d)	mm	0 / +0,021	25,010	25,009	25,012	25,008	25,009
2	Quote 22,5 (a)	mm	0 / -0,120	22,410	22,420	22,415	22,430	22,417
3	Quote 95 (a)	mm	-	94,85	94,95	94,89	94,88	94,89
4	Quote 75 (e)	mm	-	10,10	10,12	10,09	10,12	10,12
5	Holes Ø 10	mm	-	15,95	15,98	15,96	16,02	16,02
6	Quote 16 (l)	mm	-	24,45	24,40	24,50	24,4	24,4
7	Quote 24,5 (z)	mm	-	59,48	59,52	59,60	59,45	59,45
8	Quote 60 (b)	mm	61 ± 2	60,8	60,9	61,5	61,1	61,1
9	Hardness (HRC)	HRC	53 ± 2	53,5	53,8	54,1	53,8	53,8
10	Hardness (HRC)	HRC	53 ± 2	53,5	53,8	54,1	53,8	53,8
11								
12								
13								
14								
15								
16								
Peso del campione Sample weight:			kg	0,218				

Da compilare

Decisioni Decisions	Approvato Approve					Respinto Fail					Deroga Deviate
	Articolo Piece	Articolo Piece	Articolo Piece	Articolo Piece	Articolo Piece	Articolo Piece	Articolo Piece	Articolo Piece	Articolo Piece	Articolo Piece	
1. Deviazione Deviation n.:	X	X	X	X	X						
2. Dimensioni Dimensions	X	X	X	X	X						
3. Laboratorio Laboratory											
4. Funzionalità Functionality											
5. Aspetto Appearance	X	X	X	X	X						

ISIR N° 0015
Rapporto di controllo di prima campionatura
Initial Sample Inspection Report

DENOMINAZIONE Part name: **Supporto UFL 005**
Fornitore Supplier name: **CF 595**

CODICE ARTICOLO Part number: **31095120**
CODICE FORNITORE Supplier code: **WJBXXITA04-S**

QTA' CONSEGNERATA Delivered quantity: **10**
QTA' CONTROLLATA Inspected quantity: **10**

ISPEZIONATO DA Inspected by: **Quality Control**
DATA Date: **13/09/2010**

DATA Date: **09/09/2010**

I campioni sono generati in accordo con le specifiche tecniche riportate nei cataloghi ISB. The samples are generated in accordance with the specifications reported in technical catalogues.

Caratteristiche controllate Inspected characteristics

Posizione Key	Dimensione nominale Specifiche materiali Nominal dimension Material specification	Unità di misura Unit of measure	Tolleranze Tolerances	Risultati della misurazione Measurement results					Esito Result	Verifica Control
				Articolo 6 Piece	Articolo 7 Piece	Articolo 8 Piece	Articolo 9 Piece	Articolo 10 Piece		
1	Bore Ø 25 (d)	mm	0 / +0,021	25,005	25,005	25,005	25,007	25,007	X	OK
2	Quote 22,5 (B)	mm	0 / -0,120	22,405	22,410	22,410	22,400	22,420	X	OK
3	Quote 95 (a)	mm	-	94,99	94,97	94,92	94,94	94,99	X	OK
4	Quote 75 (e)	mm	-	10,13	10,05	10,06	10,06	10,04	X	OK
5	Holes Ø 10	mm	-	16,01	16,04	16,06	15,97	16,03	X	OK
6	Quote 16 (l)	mm	-	24,45	24,40	24,50	24,4	24,45	X	OK
7	Quote 24,5 (z)	mm	-	59,52	59,60	59,49	59,62	59,44	X	OK
8	Quote 60 (b)	mm	61 ± 2	61,4	61,6	61,1	60,8	61,5	X	OK
9	Hardness (HRC)	HRC	53 ± 2	52,5	52,1	51,6	53,0	53,2	X	OK
10	Hardness (HRC)	HRC	53 ± 2	52,5	52,1	51,6	53,0	53,2	X	OK
11										
12										
13										
14										
15										
16										
Peso del campione Sample weight:			kg	0,218						

Da compilare a cura di To be filled by ISB

Decisioni Decisions	Approvato Approve					Respinto Fail					Deroga Deviate
	Articolo Piece	Articolo Piece	Articolo Piece	Articolo Piece	Articolo Piece	Articolo Piece	Articolo Piece	Articolo Piece	Articolo Piece		
1. Deviazione Deviation n.:											
2. Dimensioni Dimensions											
3. Laboratorio Laboratory											
4. Funzionalità Functionality											
5. Aspetto Appearance											

Commenti Notes
All samples comply to the requirements.
Final acceptance is given.

Data Date: **13/09/2010**
Firma Signature: **Quality Control**

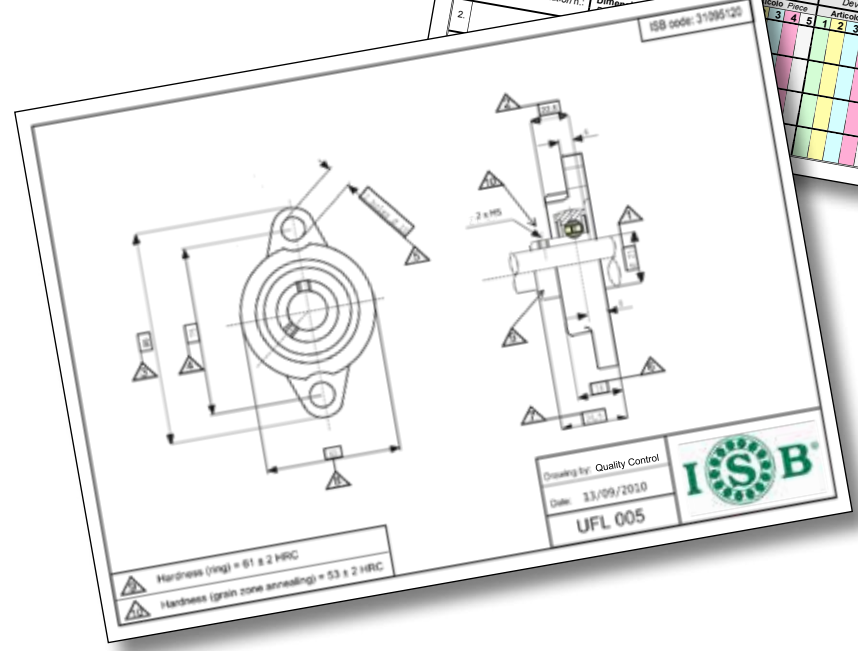

AGRICOLTURA
CASA
INDUSTRIA
MACCHINARI
TEMPO LIBERO
UFFICIO
VEICOLI

AGRICULTURE
HOME
INDUSTRY
MACHINERIES
FREE TIME
OFFICE
VEHICLES



Le numerose linee di cuscinetti e componenti ISB® consentono di soddisfare le esigenze nei più svariati settori applicativi. L'ampia gamma e la qualità dei prodotti è tale da garantire applicazioni anche in condizioni d'impiego gravose. I cuscinetti e componenti ISB® vantano una produzione articolata e completa di tutte le tipologie, indicata pertanto a soddisfare le più svariate esigenze applicative.

The diverse product lines of ISB® bearings and components make it possible to satisfy the needs of a wide variety of fields of application. The wide range and quality of products is also a guarantee for heavy duty applications. ISB® bearings and components are available in versions across-the-board and can meet the requirements of a wide variety of demanding applications.



CUSCINETTI
BEARINGS

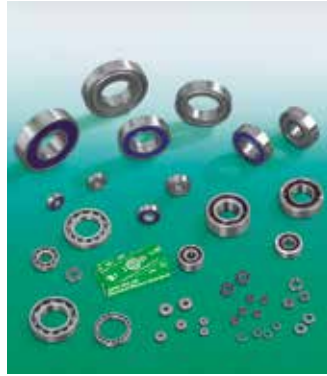

CUSCINETTI PER APPLICAZIONI
"BASSA RUMOROSITÀ"
BEARINGS FOR "LOW NOISE"
APPLICATIONS



CUSCINETTI DI SUPER PRECISIONE
SUPER PRECISION BEARINGS



CUSCINETTI A RULLINI
NEEDLE BEARINGS



CUSCINETTI DI BASE
SLEWING BEARINGS



SUPPORTI AUTOALLINEANTI
SELF-ALIGNING BEARING UNITS



SNODI SFERICI
TESTE A SNODO - FORCELLE
SPHERICAL PLAIN BEARINGS
ROD ENDS - CLEVISES



BOCCOLE
BUSHES



COMPONENTI PER LA
MOVIMENTAZIONE LINEARE
COMPONENTS FOR LINEAR MOTION



RUOTE LIBERE
FREE WHEELS



SFERE PORTANTI - SFERE DI PRECISIONE
RULLI E RULLINI DI PRECISIONE
BALL TRANSFER UNITS
PRECISION BALLS
PRECISION ROLLERS AND NEEDLES



CUSCINETTI DI GRANDI DIMENSIONI
LARGE BEARINGS



CUSCINETTI A SFERE IN
MATERIALI POLIMERICI
POLYMERIC BALL BEARINGS



CUSCINETTI BONDERIZZATI
PER ALTE TEMPERATURE
BONDERIZED BEARINGS FOR
HIGH TEMPERATURES



ANELLI DI TENUTA METALLICI
PER CUSCINETTI
METALLIC SEALS FOR BEARINGS



PRODOTTI IN ACCIAIO INOX
STAINLESS STEEL PRODUCTS

	Titolo Title	Pag. Page
1.	Struttura supporti - Structure of bearing units	1
1.1	ISB® marchio sinonimo di qualità - ISB® is a trademark which identifies quality	2
2.	Caratteristiche tecniche costruttive - Technical constructive characteristics	2
2.1	Materiale dei cuscinetti - Bearing material	3
2.2	Materiale delle gabbie e dei rivetti - Cages and rivets material	4
2.3	Materiale del corpo - Housing material	4
2.4	Materiali degli altri componenti - Other components material	5
2.5	Tenute e protezioni - Seals and covers	6
3.	Tolleranze e simboli - Symbols and tolerances	6
3.1	Tolleranze del diametro dell'alloggiamento - Tolerance of spherical bore diameter of housings	9
3.2	Tolleranze dei supporti ritti - Bearing units tolerances	10
3.3	Tolleranze dei supporti flangiati - Flange bearing units tolerances	11
3.4	Tolleranze dei supporti scorrevoli ed a cartuccia - Take-up and cylindrical cartridge bearing units tolerances	12
3.5	Tolleranze degli alberi - Shafts tolerances	13
3.6	Precisione dimensionale delle fusioni - Dimensional accuracies of castings	14
3.7	Tolleranze delle fusioni - Castings tolerances	14
3.8	Carico ammissibile dei supporti - Allowed load of bearing units	15
3.9	Carico ammissibile dei supporti in lamiera stampata - Allowed load of pressed steel housings	16
3.10	Coefficiente di sicurezza - Safety factor	16
3.11	Velocità massima (giri al minuto) - Max rpm.	17
4.	Coefficienti di carico e durata - Load ratings and life	17
4.1	Coefficiente di carico statico C_0 - Static load ratings C_0	20
4.2	Coefficiente di sicurezza statico S_0 - Static load safety factor S_0	20
4.3	Carico radiale dinamico e statico equivalente - Equivalent radial dynamic and static load	21
5.	Gioco dei cuscinetti a sfere - Clearance of ball bearings	21
5.1	Tipologia giuoco radiale - Types of radial clearance	22
6.	Lubrificazione - Lubrication	24
6.1	Supporti esenti da manutenzione - Maintenance-free bearing units	24
6.2	Supporti ri-lubrificabili - Re-greaseable bearing units	25
6.3	Periodicità della lubrificazione - Periodicity of lubrication	25
6.4	Accorgimenti per la lubrificazione - Rules for lubrication	26
6.5	Quantità di grasso - Grease quantity	27
6.6	Ingrassatori - Grease nipple	28
6.7	Tabella dei lubrificanti - Tables of lubricants	29
7.	Montaggio e smontaggio - Mounting and disassembly	30
7.1	Fissaggio con grani - Setscrews fixing	31
7.2	Fissaggio con bussola di trazione - Taper adapter fixing	32
7.3	Fissaggio con anello eccentrico di serraggio - Eccentric collar locking fixing	33
7.4	Movimento assiale dovuto all'espansione o al restringimento - Axial movement due to expansion and shrinkage	34
7.5	Smontaggio del supporto - Disassembly of bearing unit	35
7.6	Sostituzione del cuscinetto - Bearing replacement	35
8.	Tabella conversione durezza - Conversion table of hardness	36
9.	Tabella conversione pollici/millimetri - Conversion table of inch/millimetres	37
10.	Tabella d'intercambiabilità - Interchangeability table	38
11.	Tipologia dei supporti e cuscinetti ISB® - ISB® Bearing units and bearings type	40
12.	Indice generale dei prodotti ISB® - ISB® Products general index	41
13.	Supporti per alta temperatura - Bearing units for high temperature	42

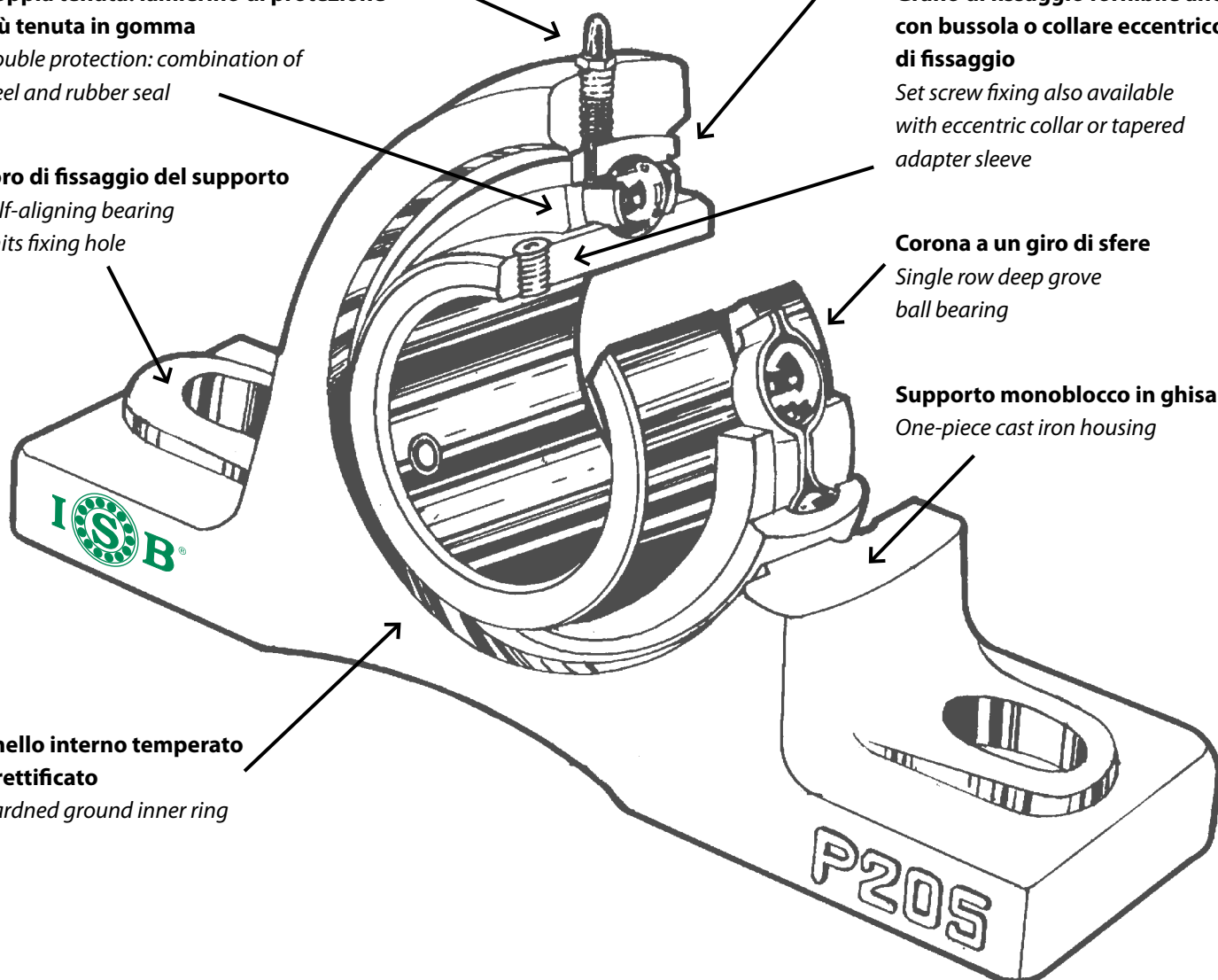
Ingrassatore per lubrificazione
Grease nipple for lubrication
Doppia tenuta: lamierino di protezione più tenuta in gomma
Double protection: combination of steel and rubber seal
Foro di fissaggio del supporto
Self-aligning bearing units fixing hole
Superficie sferica orientabile
Self-aligning surface
Grano di fissaggio fornibile anche con bussola o collare eccentrico di fissaggio
Set screw fixing also available with eccentric collar or tapered adapter sleeve
Corona a un giro di sfere
Single row deep groove ball bearing
Supporto monoblocco in ghisa
One-piece cast iron housing
Anello interno temperato e rettificato
Hardened ground inner ring

Il marchio **ISB®**, rappresenta una gamma d'articoli tecnici la cui produzione viene affidata ad un pool di costruttori, che hanno saputo mettere a frutto l'esperienza maturata da ormai diversi decenni nel settore. L'elevato know-how tecnico insieme ad apparecchiature d'alto livello sono in grado di garantire una produzione con standard di qualità elevati, sia per ciò che concerne le fasi di produzione, che il controllo dei prodotti finiti. All'interno di questo catalogo tecnico viene illustrata la gamma dei prodotti; inoltre si ricorda che per applicazioni speciali è possibile contattare l'ufficio tecnico.

Lo scopo principale di questo catalogo tecnico è di aiutare i progettisti, cercando di fornire loro le informazioni necessarie per trovare le migliori applicazioni e soluzioni possibili per ciò che riguarda le attività di loro competenza.

La prima parte del catalogo tecnico, illustra le caratteristiche tecniche generali di tutti i supporti in ghisa e dei cuscinetti **ISB®** (caratteristiche costruttive, tolleranze, coefficienti di carico e durata, giuoco del cuscinetto, lubrificazione, ed altre informazioni di vario genere), a seguito vengono indicate le tabelle dimensionali dei prodotti. Nella seconda parte del catalogo, sono illustrate le caratteristiche e le tabelle dimensionali dei supporti della serie pesante, dopodiché nella terza parte si passerà ai supporti in plastica.

Tutte le caratteristiche tecniche di costruzione, sono in accordo con le norme ISO e DIN, questo per garantire un prodotto d'elevata qualità, che mantenga le medesime caratteristiche nel tempo e che sia intercambiabile con i marchi più prestigiosi a livello mondiale.

*The **ISB®** trademark represents a range of technical articles, the production of which is entrusted to a pool of constructors who, exploit their several decades of experience in the sector. High level technical know-how together with advanced equipment guarantee elevated production standards both in the productive phase as well as the quality control phase on the finished product. This technical catalogue illustrates our range of products; though special applications are possible by contacting our technical office as well.*

The principal objective of this technical catalogue is to help project managers by furnishing them with the necessary information to find the best applications and solutions possible for the activity of their competence.

*The first part of this technical catalogue illustrates the general technical characteristics of all the housings in cast iron and the **ISB®** ball bearings (constructive characteristics, tolerances, load and duration coefficients, clearance of the ball bearing, lubrication and various other general information), followed by tables with the sizes of the products. In the second part of the catalogue the characteristics are illustrated in the tables the sizes of the heavy series housings are listed, after which is the third part which moves to the plastic housings.*

All of the technical characteristics of construction are in accordance with ISO and DIN rules, in order to guarantee an elevated product which maintains the same characteristics over time and is interchangeable with more well known brands on a world wide level.

I supporti **ISB®** sono costruiti in molteplici esecuzioni, con corpo esterno in ghisa, in lega d'alluminio, in lamiera d'acciaio stampato ed in plastica. I supporti sono forniti completi di cuscinetto, dotato di anello esterno sferico che può oscillare nella corrispondente pista ricavata nel supporto, in modo tale da compensare qualsiasi difetto d'allineamento, eliminando le sollecitazioni tra albero e supporto. Il cuscinetto inserito nell'alloggiamento del supporto, è corrispondente per le sue caratteristiche costruttive interne ai cuscinetti della serie 62 o 63 secondo le tabelle ISO.

***ISB®** housings are constructed in multiple executions, with external parts in cast iron, bound with aluminium, in moulded steel sheets and in plastic.*

The housing units are supplied complete with ball bearing, provided with external ball rings which can oscillate in the corresponding track hollowed out in the casting, in such a way as to compensate for any defect of alignment, eliminating solicitation between the shaft and the prop. It corresponds to the internal constructive characteristics of the 62 or 63 series according to the ISO tables.

Su entrambi i lati del cuscinetto, sono montate delle guarnizioni di tenuta, studiate e particolarmente indicate per garantire una perfetta tenuta ed evitare così eventuali infiltrazioni di polvere, umidità e fluidi di vario genere. Tutti i cuscinetti sono pre-ingrassati e ri-lubrificabili, fatta eccezione per le serie: CB - RB - SA - SB, che sono lubrificati per tutto l'arco della loro vita.

Nel caso che i supporti debbano essere utilizzati in condizioni particolarmente critiche, come in ambienti dove operano aziende agricole, siderurgiche, fonderie, tutti i supporti possono essere forniti di coperchi di protezione supplementare. I coperchi possono essere costruiti in ghisa grigia o in lamiera d'acciaio o in plastica e sono costituiti in modo tale da garantire anche un'eventuale sostituzione delle tenute in gomma, con comuni anelli in feltro. Esistono anche dei coperchi chiusi, utilizzabili in applicazioni ove l'albero non è passante.

Specially studied and particularly indicated resistance gaskets are located on both sides of the ball bearing, to guarantee perfect resistance, this avoids eventual infiltration from dust, humidity and fluids of various types.

All of the ball bearings are pre-lubricated and can be lubricated repeatedly, except the series: CB - RB - SA - SB, which are lubricated for their lifetime.

Should the housing be used in particularly critical conditions such as the ambient where agricultural companies or iron and steel foundries operate, all of the housings can be supplied with supplementary protective covers.

The covers can be constructed in grey cast iron or in steel sheets or in plastic and are constructed in such a way as to guarantee even eventual substitution of rubber seals with common felt rings. There are also closed covers used in applications where the shaft does not pass.

2.1

MATERIALE DEI CUSCINETTI

BEARINGS MATERIAL

Il materiale delle piste di rotolamento e delle sfere dei cuscinetti, deve avere la necessaria durezza e mantenere le sotto indicate qualità:

1. elevata resistenza contro ripetuti sforzi, che possono causare fratture per affaticamento della superficie nelle piste di rotolamento, che regolano la vita del cuscinetto.
2. elevata resistenza ed elasticità dei materiali per prevenirne la deformazione, nel momento in cui sono applicati dei forti carichi sulla superficie.
3. elevata resistenza all'abrasione, per contrastare efficacemente l'attrito radente tra gabbia e sfere.
4. elevata resistenza contro rotture causate da urti, guasti e/o avarie per errate applicazioni o montaggi impropri.
5. piccoli cambiamenti che possono avvenire nel tempo, per quanto riguarda le dimensioni e la forma dovuti a sollecitazioni interne o variazioni di struttura.

GCr15 acciaio <JIS G4805> (acciaio con elevato contenuto di carbonio e cromo, per cuscinetti), questa tipologia d'acciaio è in grado di soddisfare quanto riportato nei punti precedenti, e la sua composizione chimica viene mostrata nella tabella che segue.

The materials used to construct the rolling track and the bearing spheres must have the necessary hardness and maintain the qualities indicated below:

1. *elevated resistance against repeated straining that can cause fractures due to wear and tear on the surface of the rolling track which regulates the life of the bearing.*
2. *elevated resistance and elasticity of the materials in order to prevent deformation when heavy loads are applied to the surface.*
3. *elevated resistance to abrasion to effectively contrast against wear and tear between the cage and the sphere.*
4. *elevated resistance against breaking caused by collision, breakage and or breakdown due to incorrect application or improper assemblage.*
5. *small changes which could occur over time due to internal solicitation or structural variations.*

GCr15 steel <JIS G4805> (steel with and elevated carbon or chrome content for bearings), is type of steel which is capable of satisfying all of the above points and the chemical composition is shown in the following table.

Composizione chimica dell'acciaio con elevato contenuto di carbonio e cromo per cuscinetti
Chemical composition of high carbon chromium bearing steel

Classificazione <i>Class</i>	Simboli <i>Symbols</i>	Carbonio <i>Carbon</i>	Silicio <i>Silicon</i>	Manganese <i>Manganese</i>	Fosforo <i>Phosphorus</i>	Zolfo <i>Sulphur</i>	Cromo <i>Chromium</i>
	JIS	C	Si	Mn	P	S	JIS
1	SUJ 1	0,95 ~ 1,10	0,15 ~ 0,35	> 0,50	> 0,025	> 0,025	0,90 ~ 1,20
2	SUJ 2	0,95 ~ 1,10	0,15 ~ 0,35	> 0,50	> 0,025	> 0,025	1,30 ~ 1,60
3	SUJ 3	0,95 ~ 1,10	0,40 ~ 0,70	0,90 ~ 1,15	> 0,025	> 0,025	0,90 ~ 1,20

Per mantenere costante la qualità nel tempo, vengono effettuati tutta una serie di controlli sotto riportati:

- analisi chimiche sulla composizione
- esplorazioni magnetiche
- prove di rumorosità e vibrazione
- corrosione da contatto con sostanze acide
- controlli visivi
- controlli della struttura al microscopio
- test di durezza dei materiali
- prove d'affaticamento

In order to maintain the quality constant over time, the entire series of tests reported below are performed:

- *chemical analysis of the composition.*
- *magnetic exploration*
- *noise and vibration tests*
- *corrosion from contact with acid substances.*
- *visual inspection*
- *microscopic inspection*
- *hardness tests on the materials*
- *stress tests*

2.2

MATERIALE DELLE GABBIE E DEI RIVETTI

CAGES AND RIVETS MATERIAL

La composizione del materiale di costruzione delle gabbie è conforme alle norme JIS G 3141; le gabbie sono costituite da lamine d'acciaio al carbonio rullato, raffreddato e pressato SPCC.

La composizione del materiale di costruzione dei rivetti è conforme alle norme JIS G 3507, filetti metallici d'acciaio al carbonio SWRCH 12A.

The composition of the material used to construct the cages conforms to JIS G 3141 norms; the cages are constructed with carbon rolled steel sheets, cooled and pressed SPCC.

The composition of the material used to construct the rivets conforms to JIS G 3507 norms, metal threads of carbon steel SWRCH 12A.

2.3

MATERIALE DEL CORPO

HOUSING MATERIAL

La composizione del materiale di costruzione delle fusioni dei supporti è HT 200 JIS G 5501 (ghisa) e le proprietà meccaniche sono illustrate nella tabella che segue:

The composition of the construction material used to fuse the housings is HT 200 JIS G 5501 (cast iron), the mechanical properties of which are illustrated in the following table:

Proprietà meccaniche delle fusioni in ghisa HT200 - *Mechanical properties of cast iron HT 200*

Classificazione Class	Spessore Thickness	Diametro della barra di prova Diameter of testing bar	Test di tensione Tension test	Test di frenatura laterale Traverse breaking test		Resistenza alla pressione Pressure strength	Test di durezza Hardness test
			Forza di tensione Tensile strenght	Forza di curvatura Bender strength	Deviazione Deflection		
	mm	mm	Kgf/mm ²	Kgf/mm ²	mm	Kgf/mm ²	HB
HT 200 JIS (FC 200)	< 06-80	13	< 32	53	1,8	75	187-255
	< 08-15	20	< 25	45	2,5	75	170-241
	< 15-30	30	< 20	40	2,5	75	170-241
	< 30-50	45	< 18	34	3,0	75	170-241
	< 50	60	< 16	31	4,5	75	160-229

2.4

MATERIALI DEGLI ALTRI COMPONENTI

OTHER COMPONENTS MATERIAL

Nella sotto indicata tabella vengono indicati quelli che sono i principali materiali utilizzati nella costruzione dei principali accessori relativi ai supporti.

The principle materials used to construct the main accessories relative to the housings are indicated in the table below.

Componenti Components	Materiale utilizzato Material used	Simboli JIS JIS symbols	Numeri JIS JIS numbers
Bussola Adapter sleeve	Acciaio al carbonio Carbon steel	S25C	JIS G 4051
Dado Nut	Acciaio al carbonio Carbon steel	S25C	JIS G 4051
Rosetta Washer	Lamine d'acciaio al carbonio rullate a freddo e pressate Cold roller carbon steel sheet and strip	SPCC	JIS G 3141
Anello di tenuta Shaft seal	Gomma nitrilica sintetica Synthetic nitrile rubber	-	-
Dispositivo di lubrificazione Slinger	Lamine d'acciaio al carbonio rullate a freddo e pressate Cold roller carbon steel sheet and strip	SPCC	JIS G 3141
Vite esagonale Hexagon set screw	Acciaio nichelato con cromo e molibdeno Nickel chromium molybdenum steel	SCM 435	JIS G 4105
Chiave esagonale Hexagon wrench key	Acciaio nichelato con cromo e molibdeno Nickel chromium molybdenum steel	SNCM 630	JIS G 4103
Ingrassatore Grease nipple	Ottone Brass	C 3604	JIS H 3250

I cuscinetti utilizzati nei supporti **ISB®** prevedono un sistema di tenuta su entrambi i lati, costituito dalla combinazione di una tenuta in gomma sintetica fissata sull'anello esterno, rinforzata in acciaio e con relativo labbro; mentre sull'anello interno viene fissato uno schermo che ruota insieme all'anello interno stesso. Questo sistema di protezione previene la fuoriuscita di grasso e l'infiltrazione d'agenti inquinanti. Oltre a quanto sopra riportato e come accennato brevemente al punto 2, possono essere utilizzati ulteriori dispositivi di protezione, come i coperchi. L'utilizzo in sinergia di entrambi i dispositivi di protezione è particolarmente indicato in quei casi dove si è in presenza di agenti esterni particolarmente aggressivi, polvere, liquidi vari o quando l'impiego avviene in ambiente esterno.

*The bearings used in **ISB®** housings provide a sealing system on both sides.*

They are constructed with a seal which has synthetic rubber fixed to the external ring and is reinforced with the relative steel lip; while fixed on the inner ring there is a shield which turns together. This protective system prevents grease from exiting and pollutants from entering.

In addition to what is reported above and as briefly mentioned in point n°2., ulterior protection devices such as covers are available. Both protection devices used at the same time is indicated in cases where the external agents are particularly aggressive such as dust, various liquids or for external use.

Le tolleranze dei cuscinetti e dei supporti sono state normalizzate a livello sia nazionale che internazionale in conformità alle norme JIS. I cuscinetti vengono in genere costruiti in classe di tolleranza standard

The tolerances of the bearings and their housings have been normalized at both national and international levels and conform to JIS norms. Generally, the bearings are constructed according to standard tolerances.

d	diametro nominale del foro <i>nominal bore diameter</i>
Δd_{mp}	scostamento del diametro del foro dal valore nominale <i>deviation of bore diameter from nominal value</i>
V_{dp}	variazione del diametro del foro <i>bore diameter variation</i>
D	diametro nominale esterno <i>nominal outer diameter</i>
ΔD_{mp}	scostamento del diametro esterno medio dal valore nominale <i>deviation of the mean outer diameter from nominal value</i>
K_{ia}	concentricità di rotazione dell'anello interno nel cuscinetto completo (precisione radiale di rotazione) <i>concentricity radial run out of assembled bearing inner ring (run out radial precision)</i>
K_{ea}	concentricità di rotazione dell'anello esterno nel cuscinetto completo (precisione radiale di rotazione) <i>concentricity radial run out of assembled bearing outer ring (run out radial precision)</i>
ΔB_s	scostamento di una singola misura dell'altezza dell'anello interno rispetto alla dimensione nominale <i>inner ring single height deviation as regards to nominal dimension</i>
ΔC_s	scostamento di una singola misura dell'altezza dell'anello esterno rispetto alla dimensione nominale <i>outer ring single height deviation as regards to nominal dimension</i>

Anello interno - Inner ring

Diametro interno (d) Inner diameter (d)				Tipo (cuscinetto con foro cilindrico) Type (cylindrical bore bearing) UC - HC - SA - SB - SER				Scostamento altezza Height deviation				Concentricità di rotazione Concentricity radial run out			
Oltre Over		Fino a Up to		Δd_{mp}				V_{dp}		ΔB_s				K_{ia}	
mm	pollici inch	mm	pollici inch	max	min	max	min	max		min	max	min	max	max	
10	0,3937	18	0,7087	+15	0	+6	0	10	4	0	-120	0	-47	15	6
18	0,7087	30	1,1811	+18	0	+7	0	12	5	0	-120	0	-47	18	7
30	1,1811	50	1,9685	+21	0	+8	0	14	6	0	-120	0	-47	20	8
50	1,9685	80	3,1496	+24	0	+9	0	16	6	0	-150	0	-59	25	10
80	3,1496	120	4,7244	+28	0	+11	0	19	7	0	-200	0	-79	30	12
120	4,7244	180	7,0866	+33	0	+13	0	22	9	0	-250	0	-98	35	14

Anello interno - Inner ring

Diametro interno (d) Inner diameter (d)				Tipo (cuscinetto con foro cilindrico) Type (cylindrical bore bearing) CB				Scostamento altezza Height deviation				Concentricità di rotazione Concentricity radial run out			
Oltre Over		Fino a Up to		Δd_{mp}				V_{dp}		ΔB_s				K_{ia}	
mm	pollici inch	mm	pollici inch	max	min	max	min	max		min	max	min	max	max	
10	0,3937	18	0,7087	0	-8	0	-3	10	4	0	-120	0	-47	15	6
18	0,7087	30	1,1811	0	-10	0	-4	12	5	0	-120	0	-47	18	7
30	1,1811	50	1,9685	0	-12	0	-5	14	6	0	-120	0	-47	20	8

Anello esterno - Outer ring

Diametro esterno (d) Outer diameter (d)				Scostamento del diametro esterno medio Deviation of the mean outer diameter				Scostamento altezza Height deviation				Concentricità di rotazione Concentricity radial run out	
Oltre Over		Fino a Up to		ΔD_{mp}				ΔC_s				K_{ea}	
mm	pollici inch	mm	pollici inch	max	min	max	min	min	max	min	max	max	
18	0,7087	30	1,1811	0	-9	0	-4	0	-120	0	-47	15	6
30	1,1181	50	1,9685	0	-11	0	-4	0	-120	0	-47	20	8
50	1,9685	80	3,1496	0	-13	0	-5	0	-150	0	-59	25	10
80	3,1496	120	4,7244	0	-15	0	-6	0	-200	0	-79	35	14
120	4,7244	150	5,9055	0	-18	0	-7	0	-250	0	-98	40	16
150	5,9055	180	7,0866	0	-25	0	-10	0	-250	0	-98	45	18
180	7,0866	250	9,8425	0	-30	0	-12	0	-300	0	-118	50	20
250	9,8425	315	12,4016	0	-35	0	-14	0	-350	0	-137	60	24

Semiangolo del cono: α
 Half angle of cone: α

$$\alpha = 2^{\circ}23'9,4''$$

$$= 2.38594^{\circ}$$

$$= 0.041643 \text{ rad}$$

(conicità 1:12)
 (taper-ratio 1:12)

Diametro maggiore teorico d_1 :
 Theoretical bigger diameter d_1 :

$$d_1 = d + \frac{1}{12}B \quad (\text{conicità } 1:12)$$

$$\quad \quad \quad (\text{taper-ratio } 1:12)$$

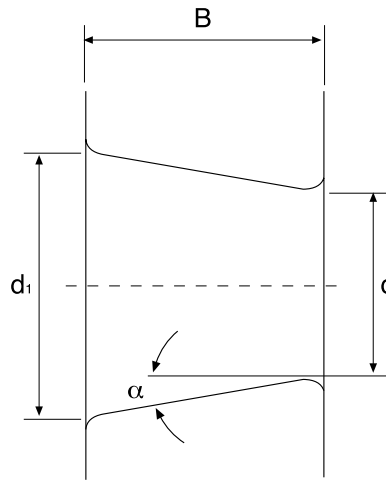

Foro conico teorico
 Theoretical bore diameter

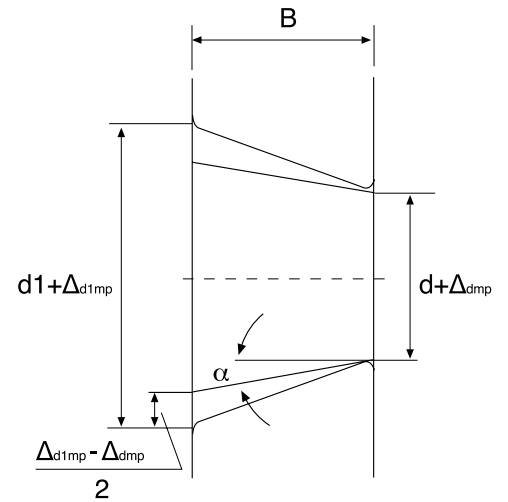

Foro conico con uno scostamento nella
 dimensione del diametro medio nella
 superficie piana
 Conical bore with deviation of mean
 diameter in flat surface

Δd_{mp}	Scostamento nella dimensione del diametro medio del foro nella superficie piana all'estremità minore teorica del foro conico <i>Deviation of mean bore diameter in a single plane (for a basically bore, Δd_{mp} refers to the theoretical small end of the conical bore)</i>
Δd_{1mp}	Scostamento nella dimensione del diametro medio del foro nella superficie piana all'estremità maggiore teorica del foro conico <i>Deviation of mean bore diameter in a single plane at the theoretical large end of a basically conical bore)</i>
V_{dp}	Variatione del diametro del foro <i>Bore diameter variation</i>
V_{dp}	Altezza dell'anello interno <i>Inner ring height</i>

Anello interno (foro conico) - Inner ring (conical bore)

Diametro interno (d) Inner diameter (d)				$+\Delta d_{mp}$				$\Delta d_{1mp} - \Delta d_{mp}$				$V_{dp}^{1)}$	
Oltre Over		Fino a Up to		max	min	max	min	min	max	min	max	max	
mm	pollici inch	mm	pollici inch										
18	0,7087	30	1,1811	+21	0	+8	0	+21	0	+8	0	13	5
30	1,1811	50	1,9685	+25	0	+10	0	+25	0	+10	0	15	6
50	1,9685	80	3,1496	+30	0	+12	0	+30	0	+12	0	19	7
80	3,1496	120	4,7244	+35	0	+14	0	+35	0	+14	0	25	10
120	4,7244	180	7,0866	+40	0	+16	0	+40	0	+16	0	31	12

1) Valido in ogni singolo piano radiale del foro - Valid for every radial flat of bore.

Tolleranza della distanza (n) dalla linea centrale dell'anello esterno sferico all'anello interno
Tolerance in distance (n) from centre line of spherical outer ring to side of inner ring

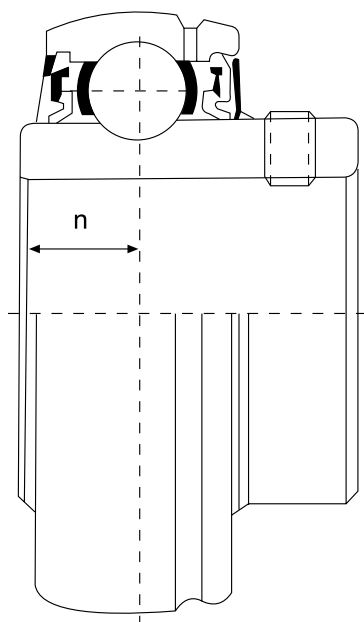

Diametro interno (d) <i>Inner diameter (d)</i>				Tolleranza (n) <i>Tolerance (n)</i>	
Oltre <i>Over</i>		Fino a <i>Up to</i>			
mm	pollici <i>inch</i>	mm	pollici <i>inch</i>		
2,5	0,0984	50	1,9685	±200	±79
50	1,9685	80	3,1496	±250	±98
80	3,1496	120	4,7244	±300	±118
120	4,7244	-	-	±350	±138

3.1

TOLLERANZE DEL DIAMETRO DELL'ALLOGGIAMENTO

TOLERANCE OF SPHERICAL BORE DIAMETER OF HOUSING

Diametro del foro sferico del supporto
Spherical bore diameter of bearing units

Diametro del foro sferico (D _s) <i>Spherical bore diameter (D_s)</i>				Scostamento del diametro medio del foro (^Δ D _{am}) <i>Mean bore diameter deviation (^ΔD_{am})</i>											
Oltre <i>Over</i>		Fino a <i>Up to</i>		Tolleranza H7 <i>H7 tolerance</i>				Tolleranza J7 <i>J7 tolerance</i>				Tolleranza K <i>K tolerance</i>			
mm	pollici <i>inch</i>	mm	pollici <i>inch</i>	min	max	min	max	min	max	min	max	min	max	min	max
30	1,1811	50	1,9685	+25	0	+10	0	+14	-11	+6	-4	+7	-18	+3	-7
50	1,9685	80	3,1496	+30	0	+12	0	+18	-12	+7	-5	+9	-21	+4	-8
80	3,1496	120	4,7244	+35	0	+14	0	+22	-13	+9	-5	+10	-25	+4	-10
120	4,7244	180	7,0866	+40	0	+16	0	+26	-14	+10	-6	+12	-28	+5	-11
180	7,0866	250	9,8425	+46	0	+18	0	+30	-16	+12	-6	+13	-33	+5	-13
250	9,8425	315	12,4016	+52	0	+20	0	+36	-16	+14	-6	-	-	-	-

Tipologia dei supporti ritri <i>Bearing units type</i>						Tolleranza h <i>Tolerance h</i>	
P203	-	-	-	-	-	±150	
P204	-	-	HP204	UP204	PL204		
P205	P305	PX05	HP205	UP205	PL205		
P206	P306	PX06	HP206	UP206	PL206		
P207	P307	PX07	HP207	UP207	PL207		
P208	P308	PX08	HP208	UP208	-		
P209	P309	PX09	HP209	UP209	PL209		
P210	P310	PX10	HP210	UP210	PL210		
P211	P311	PX11	-	-	-		±200
P212	P312	PX12	-	-	-		
P231	P313	PX13	-	-	-		
P214	P314	PX14	-	-	-		
P215	P315	PX15	-	-	-		
P216	P316	PX16	-	-	-		
P217	P317	PX17	-	-	-		
P218	P318	PX18	-	-	-		
-	P319	-	-	-	-	±300	
-	P320	PX20	-	-	-		
-	P321	-	-	-	-		
-	P322	-	-	-	-		
-	P324	-	-	-	-		
-	P326	-	-	-	-		
-	P328	-	-	-	-		

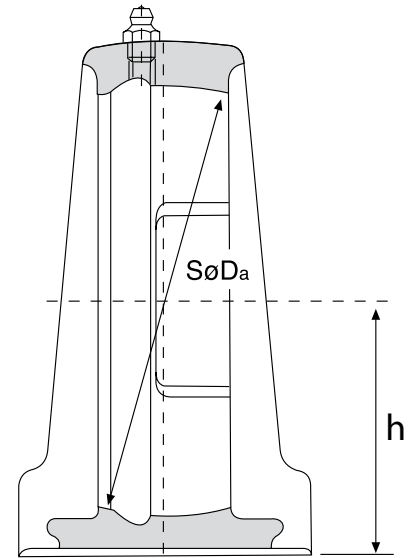

3.3

TOLLERANZE DEI SUPPORTI FLANGIATI

FLANGE BEARING UNITS TOLERANCES

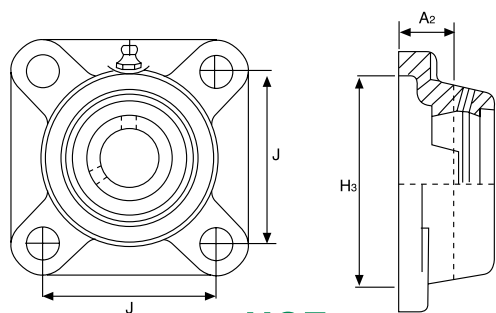

UCF

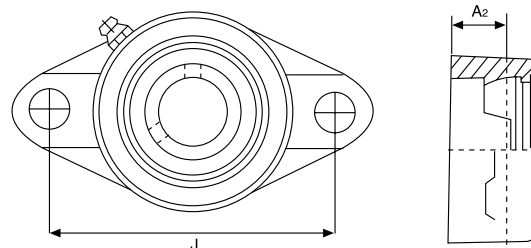

UCFL

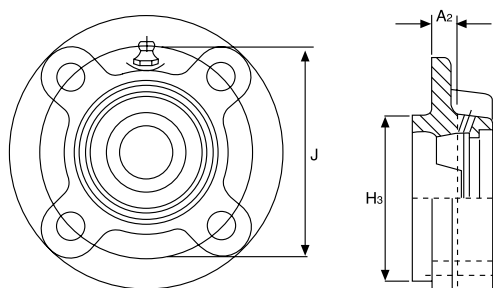

UCFC

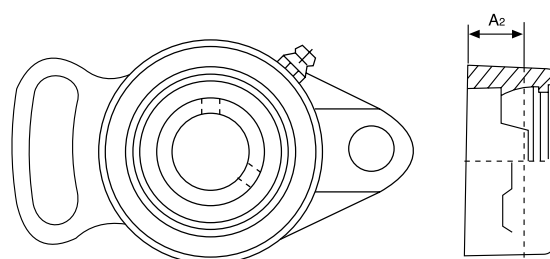

UCFA

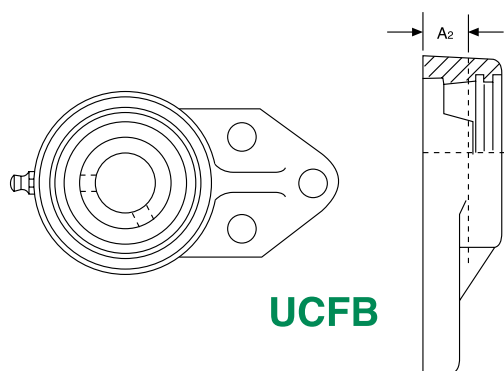

UCFB

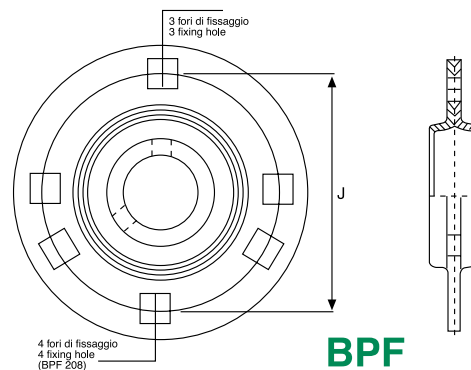

BPF

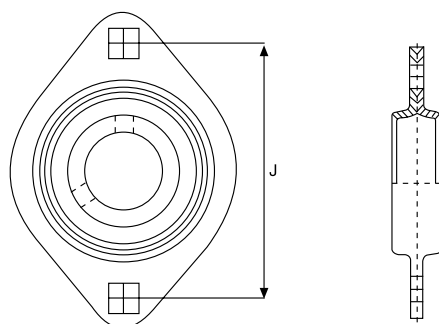

BPFL

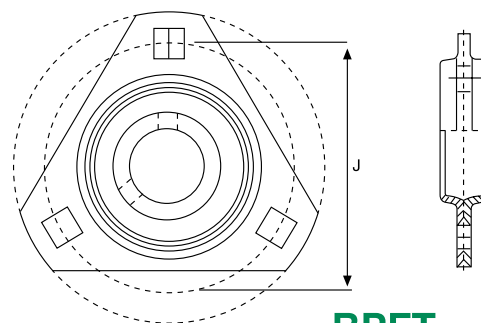

BPFT

Tipologia dei supporti flangiati Flange bearing units type							Tolleranza J Tolerance		Tolleranza A₂ Tolerance		Spostamenti H ₃ H ₃ deviation								Tolleranza A₂ Tolerance					
											FC2				FCX						FS3			
											max	min	max	min	max	min	max	min			max	min	max	min
F2...	F3...	FX...	FC2...	FS3...	FL2...	FL3...																		
F204	-	-	FC204	-	FL204	-																		
F205	F305	FX05	FC205	FS305	FL205	FL305					0	-46	0	-18	0	-46	0	-18	0	-46	0	-18		
F206	F306	FX06	FC206	FS306	FL206	FL306	±700	±276	±500	±197									0	-54	0	-21	200	79
F207	F307	FX07	FC207	FS307	FL207	FL307													0	-54	0	-21		
F208	F308	FX08	FC208	FS308	FL208	FL308													0	-54	0	-21		
F209	F309	FX09	FC209	FS309	FL209	FL309													0	-54	0	-21		
F210	F310	FX10	FC210	FS310	FL210	FL310													0	-54	0	-21		
F211	F311	FX11	FC211	FS311	FL211	FL311													0	-63	0	-25		
F212	F312	FX12	FC212	FS312	FL212	FL312													0	-63	0	-25		
F213	F313	FX13	FC213	FS313	FL213	FL313													0	-63	0	-25		
F214	F314	FX14	FC214	FS314	FL214	FL314													0	-63	0	-25		
F215	F315	FX15	FC215	FS315	FL215	FL315													0	-63	0	-25	300	118
F216	F316	FX16	FC216	FS316	FL216	FL316													0	-63	0	-25		
F217	F317	FX17	FC217	FS317	FL217	FL317													0	-72	0	-28		
F218	F318	FX18	FC218	FS318	FL218	FL318	±1000	±394	±800	±315	0	-72	0	-28	0	-72	0	-28	0	-72	0	-28		
-	F319	-	-	FS319	-	FL319													0	-72	0	-28		
-	F320	FX20	-	FS320	-	FL320													0	-72	0	-28		
-	F321	-	-	FS321	-	FL321													0	-72	0	-28		
-	F322	-	-	FS322	-	FL322													0	-72	0	-28		
-	F324	-	-	FS324	-	FL324													0	-72	0	-28		
-	F326	-	-	FS326	-	FL326													0	-72	0	-28		
-	F328	-	-	FS328	-	FL328													0	-72	0	-28		
-	F319	-	-	FS319	-	FL319													0	-81	0	-32		
-	F320	FX20	-	FS320	-	FL320													0	-81	0	-32	400	157
-	F321	-	-	FS321	-	FL321													0	-81	0	-32		
-	F322	-	-	FS322	-	FL322													0	-81	0	-32		
-	F324	-	-	FS324	-	FL324													0	-81	0	-32		
-	F326	-	-	FS326	-	FL326													0	-81	0	-32		
-	F328	-	-	FS328	-	FL328													0	-81	0	-32		

3.4 TOLLERANZE DEI SUPPORTI SCORREVOLI ED A CARTUCCIA TAKE-UP AND CYLINDRICAL CARTRIDGE BEARING UNITS TOLERANCES

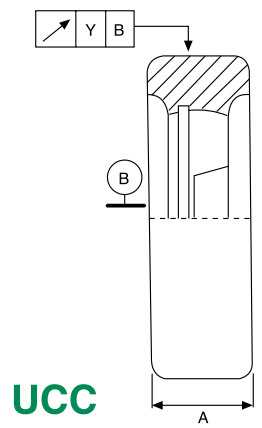
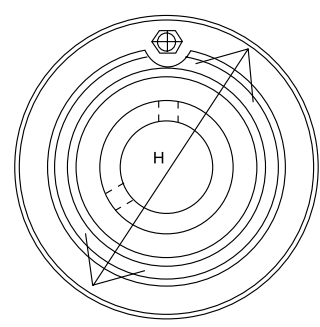
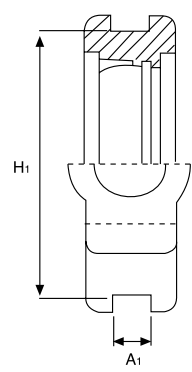
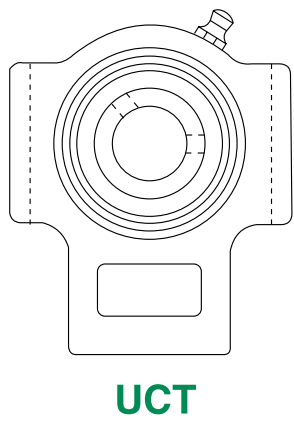

Tipologia dei supporti scorrevoli Take-up bearing units type			Tolleranza A ₁ Tolerance		Tolleranza H ₁ Tolerance		Parallelismo di guida Parallelism of sliding bolt		Tipologia dei supporti a cartuccia Cylindrical cartridge bearing units type			Tolleranza H H Tolerance						Difetto radiale Y Spigot run-out max		Scostamento A Deviation	
			max min	max min	max min	max min						C2...		CX...		C3...					
												max min	max min	max min	max min	max min	max min				
T2...	TX...	T3...							C2...	CX...	C3...										
T204	-	T304							C204	CX204	C304	0	0	-	-	-	-				
T205	TX205	T305							C205	CX205	C305	-30	-12								
T206	TX206	T306	+200	+79	0	0	500	197	C206	CX206	C306			0	0	0	0	200	79		
T207	TX207	T307	0	0	-500	-197			C207	CX207	C307			-35	-14	-35	-14				
T208	TX208	T308							C208	CX208	C308	0	0								
T209	TX209	T309							C209	CX209	C309	-35	-14								
T210	TX210	T310							C210	CX210	C310										
T211	TX211	T311							C211	CX211	C311			0	0						
T212	TX212	T312							C212	CX212	C312	0	0			-40	-16				
T213	TX213	T313							C213	-	C313										
T214	TX214	T314					600	236	-	-	C314							300	118		
T215	TX215	T315							-	-	C315										
T216	TX216	T316							-	-	C316										
T217	TX217	T317							-	-	C317			0	0						
-	-	T318	+300	+118	0	0			-	-	C318			-46	-18						
-	-	T319	0	0	-800	-315			-	-	C319										
-	-	T320							-	-	C320										
-	-	T321					700	276	-	-	C321			0	0						
-	-	T322							-	-	C322			-52	-20			400	157		
-	-	T324							-	-	C324										
-	-	T326					800	315	-	-	C326			0	0						
-	-	T328							-	-	C328			-57	-22						

3.5 TOLLERANZE DEGLI ALBERI SHAFTS TOLERANCES

Le tolleranze degli alberi, sono influenzate e determinate principalmente da due fattori; il diametro ed il numero dei giri che devono compiere. Nel caso l'albero preveda un impiego con un numero di giri basso, si possono utilizzare tolleranze h 9, mentre nei casi in cui gli alberi devono compiere molti giri è preferibile utilizzare tolleranze più ristrette.

The tolerances of the shafts are influenced and determined mainly by two factors: the diameter and the number of rounds to be completed. Should the shaft require a low number of rounds, the tolerance can be h9, whereas, if the shaft requires a higher number of rounds it is preferable to use a more narrow tolerance.

Tolleranze albero per cuscinetti serie UC - SB - SA
Shaft tolerance for UC - SB - SA bearings series

Dimensione dell'albero (d) Shaft dimension (d)				Tolleranza diametro dell'albero Diameter shaft tolerance							
Oltrev/Over		Fino a /Up to		j6		h6		h7		h8	
mm	pollici inch	mm	pollici inch	dn > 120 000		dn ≤ 120 000		dn ≤ 100 000		dn ≤ 60 000	
10	0,3937	18	0,7087	+8 ~ -3	+3 ~ -1	0 ~ -11	0 ~ -4	0 ~ -18	0 ~ -7	0 ~ -27	0 ~ -11
18	0,7087	30	1,1811	+8 ~ -4	+4 ~ -2	0 ~ -13	0 ~ -5	0 ~ -21	0 ~ -8	0 ~ -33	0 ~ -13
30	1,1811	50	1,9685	+11 ~ -5	+4 ~ -2	0 ~ -16	0 ~ -6	0 ~ -25	0 ~ -10	0 ~ -39	0 ~ -15
50	1,9685	80	3,1496	+12 ~ -7	+5 ~ -3	0 ~ -19	0 ~ -7	0 ~ -30	0 ~ -12	0 ~ -46	0 ~ -18
80	3,1496	120	4,7244	+13 ~ -9	+5 ~ -4	0 ~ -22	0 ~ -9	0 ~ -35	0 ~ -14	0 ~ -54	0 ~ -21
120	4,7244	180	7,0866	+14 ~ -11	+6 ~ -4	0 ~ -25	0 ~ -10	0 ~ -40	0 ~ -16	0 ~ -63	0 ~ -25

Tolleranze albero per cuscinetti serie UK
Shaft tolerance for UK bearings series

Dimensione dell'albero (d) Shaft dimension (d)				Tolleranza diametro dell'albero Diameter shaft tolerance							
OltrevOver		Fino a Up to		h8		h9		h10		h11	
mm	pollici inch	mm	pollici inch	Superiore Upper		Inferiore Lower		Superiore Upper		Inferiore Lower	
10	0,3937	18	0,7087	0 - 27	0 - 11	- -	- -	- -	- -	- -	- -
18	0,7087	30	1,1811	0 - 33	0 - 13	0 - 52	0 - 20	0 - 84	0 - 33	0 - 120	0 - 47
30	1,1811	50	1,9685	0 - 39	0 - 15	0 - 62	0 - 24	0 - 100	0 - 39	0 - 160	0 - 63
50	1,9685	80	3,1496	0 - 46	0 - 18	0 - 74	0 - 29	0 - 120	0 - 47	0 - 190	0 - 75
80	3,1496	120	4,7244	0 - 54	0 - 21	0 - 87	0 - 34	0 - 140	0 - 55	0 - 200	0 - 79
120	4,7244	180	7,0866	0 - 63	0 - 25	0 - 100	0 - 39	0 - 160	0 - 63	0 - 250	0 - 98

3.6

PRECISIONE DIMENSIONALE DELLE FUSIONI

DIMENSIONAL ACCURACIES OF CASTINGS

Per conoscere il grado di precisione dimensionale delle fusioni, quando questo valore non è specificato, sarà opportuno far riferimento allo standard **JIS B 0405** (valore che rappresenta lo scostamento medio dimensionale ammissibile, in assenza di valori indicati).

When the dimensional accuracy of the casting is not specified simply refer to the **JIS B 0405** standard (the average deviation admissible in absence of indicated values).

Dimensioni Dimensions				Tolleranza dimensionale della classe media Middle class dimensional tolerance	
Superiore Upper		Incluso Included			
mm	pollici inch	mm	pollici inch		
0,5	0,0197	6	0,2362	±100	±39
6	0,2362	30	1,1811	±200	±79
30	1,1811	120	4,7244	±300	±118
120	4,7244	315	12,4016	±500	±197
315	12,4016	1000	39,3701	±800	±315

3.7

TOLLERANZE DELLE FUSIONI

CASTINGS TOLERANCES

La precisione dimensionale della fusione segue lo standard **JIS B 0407** (scostamento medio delle dimensioni in assenza d'indicazione sulla tolleranza della fusione).

The dimensional accuracy of the castings is done according to **JIS B 0407** (average deviation of the dimensions when the tolerance is absent from the casting).

Tolleranza nella lunghezza <i>Tolerance in length</i>						Tolleranza nello spessore <i>Tolerance in thickness</i>					
Dimensioni <i>Dimensions</i>				Tolleranza <i>Tolerance</i>		Dimensioni <i>Dimensions</i>				Tolleranza <i>Tolerance</i>	
Superiore <i>Over</i>		Incluso <i>Included</i>				Superiore <i>Over</i>		Incluso <i>Included</i>			
mm	pollici <i>inch</i>	mm	pollici <i>inch</i>			mm	pollici <i>inch</i>	mm	pollici <i>inch</i>		
-	-	120	4,7244	±1500	±591	-	-	-	-	-	-
120	4,7244	250	9,8425	±2000	±787	-	-	10	0,3937	±1500	±591
250	9,8425	400	15,7480	±3000	±1181	10	0,3937	18	0,7087	±2000	±787
400	15,7480	800	31,4961	±4000	±1575	18	0,7087	30	1,1811	±3000	±1181
800	31,4961	1600	62,9921	±6000	±2362	30	1,1811	50	1,9685	±3500	±1378

3.8 CARICO AMMISSIBILE DEI SUPPORTI ALLOWED LOAD BEARING UNITS

La capacità di carico dei supporti è determinata principalmente da due fattori:

- la forma
- la direzione del carico.

Visto che ogni supporto ha caratteristiche diverse nella forma, può risultare difficile calcolare le capacità di carico permesse. In tutti i casi è sempre opportuno prestare attenzione sulla direzione della forza applicata, che può essere verso il basso, verso l'alto, orizzontale o assiale.

The housing load is determined principally by two factors:

- *the form*
- *the direction of the load*

As each housing has different characteristics in different forms, it can be difficult to calculate the permitted load capacity. In any case, it is always helpful to consider the direction of the force applied. The direction can be upward, downward, horizontal or axial.

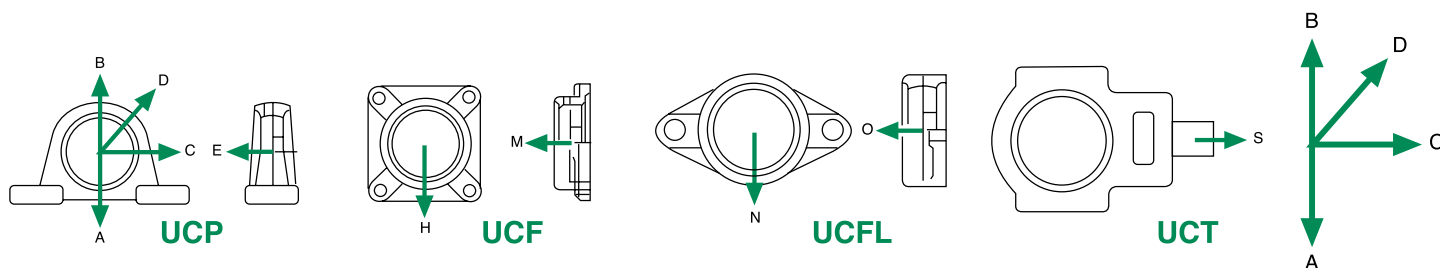

A/H/N Direzione verso il basso
B Direzione verso l'alto
C/S Direzione in orizzontale
D Direzione a 45°
E/M/O Direzione assiale

A/H/N Downward direction
B Upward direction
C/S Horizontal direction
D 45° direction
E/M/O Axial direction

Dimensioni Dimensions	Carico statico di rottura - Static ratings load									
	Tipo - Type					Tipo - Type		Tipo - Type		Tipo - Type
	UCP					UCF		UCFL		UCT
	A	B	C	D	E	H	M	N	O	S
203	69	29	49	22	10	-	-	-	-	-
204	79	32	54	24	16	42	17	23	11	33
205	92	36	59	27	17	65	24	37	15	37
206	117	49	88	34	21	65	29	37	19	40
207	156	59	98	43	23	63	35	40	22	56
208	176	64	107	45	24	69	38	40	26	80
209	186	68	117	48	25	98	46	60	31	76
210	186	73	137	55	31	98	49	60	38	84
211	205	80	147	58	33	90	55	72	43	95
212	274	107	166	71	43	90	60	86	47	98
213	284	117	186	81	49	166	67	96	60	127
214	313	117	196	82	54	186	74	98	68	127
215	323	127	205	90	56	186	78	107	70	127
216	352	147	264	107	64	166	84	127	84	137
217	441	166	274	117	73	205	93	137	92	156
218	470	186	323	127	117	245	107	137	137	-

3.9

CARICO AMMISSIBILE DEI SUPPORTI IN LAMIERA STAMPATA

ALLOWED LOAD OF PRESSED STEEL HOUSINGS

I supporti in lamiera stampata **ISB**® quando vengono sottoposti a dei carichi potrebbero presentare delle deformazioni. Tali deformazioni possono variare a seconda sia della direzione che dall'ammontare del carico stesso, inoltre anche la forma del supporto e lo spessore dei lamierini possono influire sull'entità delle deformazioni.

Da quanto sopra esposto si deduce che il carico ammissibile deve essere tale che la deformazione provocata, non pregiudichi la funzionalità del supporto stesso.

Il carico ammesso sarà approssimativamente 1/3 del valore di carico base in direzione radiale ed 1/3 del carico radiale permesso in direzione assiale.

*When the housings in sheets stamped **ISB**® are subjected to loads, deformations could present themselves. Such deformations may vary according to the direction of the total load itself, furthermore, also the form of the housing or the thickness of the sheet can influence the entity of the deformations. From all of the above we can deduct that the allowable load should be such that the deformation provoked does not prejudice the functionality of the housing itself. The allowable load will be approximately 1/3 of the base load value in a radial direction and 1/3 of the radial load permitted in axial direction*

3.10

COEFFICIENTI DI SICUREZZA

SAFETY FACTOR

Prima dell'impiego di un supporto è necessario determinare l'intensità e la direzione del carico tenendo conto dei relativi fattori di sicurezza. Per stabilire il carico ammissibile bisogna dividere il valore del carico statico di rottura per il fattore di sicurezza.

Before using a housing unit it is necessary to determine the intensity and direction of the load considering the pertinent factor of security. To establish the admissible load it is necessary to divide the value of static load by the security factor.

Condizioni di carico <i>Load conditions</i>	Carico permanente <i>Permanent load</i>	Carico vibratorio <i>Vibratory load</i>	Carico improvviso <i>Unexpected load</i>
Coefficiente di sicurezza <i>Safety factor</i>	4	10	15

3.11 VELOCITÀ MASSIMA (GIRI AL MINUTO)

MAX RPM.

Tipo <i>Type</i>	Diametro <i>Diameter</i>	Tolleranza max. ammissibile n. giri <i>Max rpm.</i>			
		j7	h7	h8	h9
UC-SB	mm				
201	12	6700	5900	4300	1600
202	15	6700	5500	4000	1500
203	17	6700	5300	3800	1400
204	20	6700	4900	3500	1250
205	25	5600	4100	2900	1050
206	30	4700	3400	2400	880
207	35	4000	3000	2100	760
208	40	3600	2600	1900	680
209	45	3300	2400	1700	620
210	50	3000	2200	1600	570
211	55	2700	2000	1400	510
212	60	2400	1800	1250	460
213	65	2300	1700	1150	420
214	70	2200	1600	1100	400
215	75	2000	1500	1000	380
216	80	1900	1400	960	350
217	85	1800	1300	900	330
218	90	1700	1200	840	310
-	-	-	-	-	-
-	-	-	-	-	-
-	-	-	-	-	-

Tipo <i>Type</i>	Diametro <i>Diameter</i>	Tolleranza max. ammissibile n. giri <i>Max rpm.</i>			
		j7	h7	h8	h9
UC-SB	mm				
305	25	5000	3700	2600	940
306	30	4300	3100	2200	800
307	35	3800	2800	2000	720
308	40	3400	2500	1700	640
309	45	3000	2200	1500	560
310	50	2700	2000	1400	500
311	55	2500	1800	1300	470
312	60	2300	1700	1150	430
313	65	2100	1500	1100	400
314	70	2000	1400	1000	370
315	75	1800	1300	930	340
316	80	1700	1250	870	320
317	85	1600	1150	810	300
318	90	1500	1100	760	280
319	95	1400	1000	720	260
320	100	1300	940	660	240
321	105	1250	900	630	230
322	110	1200	830	590	210
324	120	1100	750	530	190
326	130	1000	680	480	180
328	140	900	620	440	160

4 COEFFICIENTI DI CARICO E DURATA

LOAD RATINGS AND LIFE

La durata dei cuscinetti volventi può essere definita come il numero di giri o di ore di funzionamento, che il cuscinetto è in grado di sopportare prima che compaiano i primi segni di fatica su uno degli anelli, sulla pista di rotolamento o sugli elementi volventi. Tali segnali d'affaticamento sono causati da ripetute sollecitazioni, che influenzano i materiali di composizione dei cuscinetti. Vi sono comunque altri fattori che possono influenzare la durata della vita di un cuscinetto, ad esempio, l'abrasione, la corrosione, il grippaggio, l'ossidazione, la ruggine.

The life of rotating bearings can be defined as the number of rounds or by the functioning hours, that the bearing is capable of withstanding before showing the first signs of wear on one of the rings, on the rotating track or on the rotating elements. Such signs of wear are caused by repeated use and are influenced by the composition materials of the bearings.

There are in any case other factors that can influence the life of a bearing; for example, abrasion, corrosion, the binding, oxidation and rust.

Questi tipi di problemi possono presentarsi per eventuali applicazioni non idonee, per un errato montaggio, per insufficiente o non avvenuta lubrificazione. I problemi sopra elencati, sono da considerarsi diversi dal cedimento dei materiali, in quanto potrebbero essere evitati con le dovute precauzioni. Ove si voglia tenere in considerazione solamente la fatica nelle superfici di lavoro del cuscinetto, si dovranno osservare le seguenti condizioni:

1. Le forze e le velocità tenute in considerazione per la valutazione del cuscinetto dovranno corrispondere a quelle riportate alle reali condizioni d'esercizio.
2. Durante l'intero periodo d'esercizio dovrà essere assicurata un'adeguata lubrificazione.
3. L'esperienza dimostra come il cedimento di molti cuscinetti sia da attribuirsi a cause diverse dalla fatica, quali: scelta di un cuscinetto di tipo inadeguato, difetti di funzionamento o di lubrificazione, presenza di particelle estranee nel cuscinetto, od altro.

La durata a fatica nominale di un singolo cuscinetto, o di una campionatura di cuscinetti identici e operanti a identiche condizioni di esercizio, consiste nella durata d'esercizio pari almeno ad un grado di affidabilità del 90%.

La durata media di un gruppo di cuscinetti è di molto superiore alla durata nominale.

La durata a fatica nominale è espressa con L_{10} (milioni di giri - coefficiente di carico dinamico) o L_{10h} (ore d'esercizio). La sotto indicata equazione, permette di calcolare la relazione tra la durata nominale, il coefficiente di carico dinamico ed il carico agente sul cuscinetto:

$$L_{10} = \left(\frac{C}{P} \right)^p$$

dove:

- L_{10} durata nominale espressa 10^6 di giri
- C coefficiente di carico dinamico del cuscinetto, espresso in N
- P carico dinamico equivalente sul cuscinetto, espresso in N
- p esponente di durata dell'equazione, con i seguenti valori:
- $P=$ 3 per i cuscinetti a sfere
- $p=$ $\frac{10}{3}$ per i cuscinetti a rulli

These types of problems can present themselves due to eventual applications which are not fit or due to mounting errors or for insufficient or lack of lubrication. The above mentioned problems should be considered differently from problems with materials that yield because they can be avoided by the necessary precautions. Where one considers only the wear and tear on the working surface of the bearing, the following conditions should be observed:

1. *The force and speed of the bearing as explained should correspond to the real conditions of the exercise in order to evaluate the bearing.*
2. *During the entire exercise period the adequate lubrication should be assured.*
3. *Experience has shown us that the yielding of many bearings can be attributed to causes other than wear and tear, such as: the choice of an adequate bearing, functional or lubrication defects, the presence of foreign particles in the bearing and other things.*

The life at nominal wear of a single bearing or of a sampling of identical bearings and operating under identical conditions of exercise, consists in the length of the exercise equal to at least a 90% level of reliability. The average life of a group of bearings is well above the nominal life. The life at nominal wear and tear is expressed as L_{10} (millions of rounds - the coefficient of a dynamic load) or L_{10h} (hours of exercise). The equation illustrated below calculates the relation between the nominal life and the coefficient of the dynamic load and the agent load on the bearing:

where:

- L_{10} the nominal life expresses 10^6 rounds
- C the coefficient of the dynamic load of the bearing, expressed in N
- P the dynamic load equivalent on the bearing, expressed in N
- p the exponent of the length of the equation with the following values:
- $P=$ 3 for spherical bearings
- $p=$ $\frac{10}{3}$ for roller bearings

Per cuscinetti utilizzati a velocità costante, la durata a fatica nominale, espressa in ore di funzionamento, potrà essere calcolata con la presente equazione:

For bearings used at constant speeds, the life at nominal wear and tear, expressed in functioning hours, can be calculated with the present equation:

$$L_{10h} = \left(\frac{10^6}{n \cdot 60} \right) \left(\frac{C}{P} \right)^p$$

dove:

where:

n velocità di rotazione, espressa in giri/minuti

n the speed of rotation, expressed in rounds per minutes

Nella determinazione delle dimensioni del cuscinetto è necessario basare i calcoli sulla durata a fatica nominale corrispondente all'effettivo impiego. Di solito questo dipende dal tipo di macchina, dalla durata richiesta e dai requisiti inerenti la sicurezza di funzionamento.

In the determination of the dimensions of the bearing it is necessary to base the calculations on the life at nominal wear and tear corresponding to the effective use. Usually this depends on the type of machine, the life requested and on the inherent functioning safety.

Le relazioni tra il regime di rotazione ed il fattore di velocità così come tra la durata nominale ed il fattore di durata sono esplicitati nella sotto riportata tabella.

The relation between the rotation regime and the speed factor as well as the relation between the nominal life and the life factor are explained in the table below.

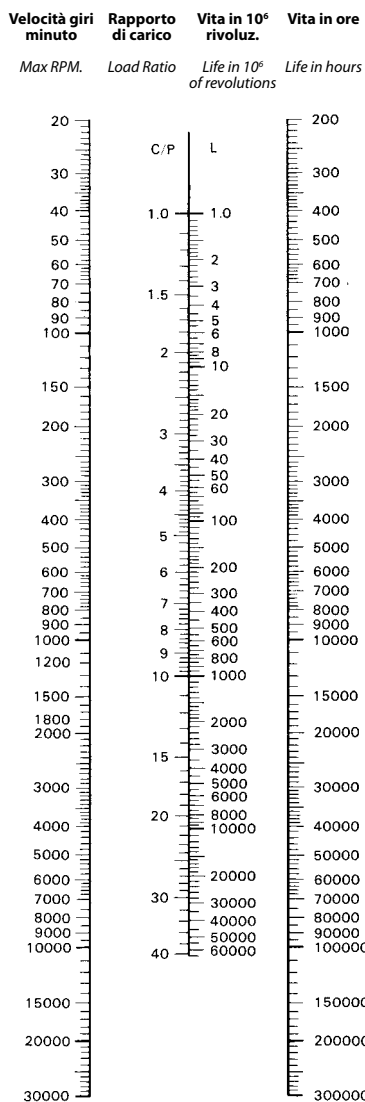

4.1

COEFFICIENTE DI CARICO STATICO C_0

STATIC LOAD RATINGS C_0

Il coefficiente di carico statico C_0 può essere considerato quando il cuscinetto è stazionario o sottoposto a rotazioni e/o oscillazioni particolarmente lente (inferiori a 10 giri max. per minuto), pertanto il coefficiente di carico statico non verrà determinato in funzione della fatica del materiale, ma in base alla deformazione permanente indotta in corrispondenza del punto di contatto tra la superficie volvente e la pista di rotolamento.

Per i cuscinetti radiali, il carico è espresso in direzione radiale, ed il punto di pressione tra i corpi volventi e le piste di rotolamento possono raggiungere i seguenti valori:

4 200 N/mm² per i cuscinetti a sfere

Nelle condizioni sopra indicate, il coefficiente di carico statico C_0 , corrisponde approssimativamente alla deformazione dell'elemento volvente più caricato ed alla deformazione di una delle piste di rotolamento uguale a 1/10 000 del diametro del corpo volvente. Quanto sopra espresso è da considerarsi valido in condizioni normali d'impiego e la deformazione può essere tollerata, senza che l'efficienza di funzionamento sia pregiudicata.

The static load coefficient C_0 can be considered when the bearing is stationary or subject to rotation and or particularly slow oscillation (below 10 rounds max. per minute), therefore the coefficient of the static load will not be determined in function of the wear on the material, but based on the permanent deformation induced at the point of contact between the rotating surface and the rolling track.

As for radial bearings, the load is expressed in radial direction and the pressure point between the rotating bodies and the rolling track can reach the following values:

4 200 N/mm² per spherical bearings

In conditions indicated above, the coefficient of the static load C_0 , corresponds approximately to the deformation of the rotating element plus the load and to the deformation of one of the rolling tracks equal to 1/10 000 of the diameter of the rotating body. All of the above can be considered valid in normal conditions of use and the deformation can be tolerated, without prejudicing the functioning efficiency.

4.2

COEFFICIENTE DI SICUREZZA STATICO S_0

STATIC LOAD SAFETY FACTOR S_0

Per quanto sopra esposto, la capacità di carico statica, determina il valore che un cuscinetto è in grado di sopportare se sottoposto a carichi, ma in assenza o ridotta presenza di movimento. Questi carichi possono comunque creare delle deformazioni, a volte permanenti, per questo motivo è importante considerare il concetto di coefficiente di sicurezza del cuscinetto contro eventuali deformazioni.

Il coefficiente di sicurezza statico, può essere determinato attraverso la seguente formula:

$$S_0 = \frac{C_0}{P_0}$$

considerando che:

- S_0 - fattore di sicurezza statico
- C_0 - coefficiente di carico statico (Kg., N)
- P_0 - carico massimo ammissibile (Kg., N)

For all of the above, the static load capacity, determines the value that a bearing is capable of supporting if subjected to loads, but in absence or in the reduced presence of movement. These loads can anyway create deformations, sometimes permanent, for this reason it is important to consider the concept of the safety factor of the bearing against eventual deformation.

The static safety factor can be determined using the following formula:

consider that:

- S_0 - static safety factor
- C_0 - static load coefficient (Kg.,N)
- P_0 - maximum load allowable (Kg.,N)

Valori indicativi del coefficiente di sicurezza statico S_0

So static safety load rating coefficient

Condizioni operative <i>Working conditions</i>	Cuscinetti a sfere <i>Roller bearings</i>
Elevata precisione di rotazione, con carichi ed urti <i>High rotation precision, with heavy loads and impact</i>	2
Precisione normale di rotazione, con maggiori esigenze di silenziosità <i>Normal rotation precision, with greater need of noiselessness</i>	1
Precisione di rotazione limitata, bassi carichi, minime esigenze di silenziosità <i>Low rotation precision, low loads and minimal need of noiselessness</i>	0,5

4.3

CARICO RADIALE DINAMICO E STATICO EQUIVALENTE

EQUIVALENT RADIAL DYNAMIC AND STATIC LOAD

Nelle tabelle dimensionali, vengono indicati i valori dei coefficienti di carico dinamico C_r e statico C_{0r} . Questi valori sono da considerarsi solamente quando il carico è puramente in direzione radiale; però i cuscinetti spesso sono soggetti a più carichi agenti, nonché ad altre situazioni, quali urti, vibrazioni ecc... pertanto occorre convertire il valore del carico dinamico radiale ed assiale in un unico valore chiamato carico radiale dinamico equivalente, per ottenere così i reali carichi applicati sui cuscinetti ed ottenere un valore molto simile alla durata del cuscinetto montato sul supporto. Il carico radiale statico rappresenta la controparte del carico radiale dinamico equivalente di un cuscinetto volvente.

The dynamic C_r and static C_{0r} load coefficient ratings are listed in the dimension tables. These ratings should be considered only when the load is purely in the radial direction; however, the bearings are often subject to several load agents, as well as other situations such as bumps, vibration etc.. therefore, the ratings of the dynamic radial and axial load should be converted to the same rating called the dynamic radial load equivalent. In this way, the rating of the real applied load obtained is very similar to the life of the bearing mounted on the housing. The static radial load represents the counterpart to the dynamic radial load equivalent of a bearing.

5

GIUOCO DEI CUSCINETTI A SFERE

CLEARANCE OF BALL BEARINGS

Uno dei principali fattori che può influenzare la durata del cuscinetto è il giuoco. Il giuoco del cuscinetto o giuoco interno (giuoco iniziale) rappresenta il valore di un cuscinetto prima di venir montato su di un albero o all'interno della sede d'alloggiamento. Il giuoco di un cuscinetto può essere inteso sia in senso radiale che assiale, quando lo spostamento dell'anello libero è in senso radiale si parlerà di giuoco radiale, mentre se il movimento è assiale, si parlerà di giuoco assiale del cuscinetto. Il giuoco radiale è determinato come il valore medio di varie misure dello spostamento totale sul piano perpendicolare all'asse del cuscinetto. Tale spostamento è tipico di uno degli anelli del cuscinetto (l'altro è fisso) durante il rotolamento in varie direzioni angolari, sia rispetto all'anello

One of the principal factors that can influence the life of a bearing is the clearance. The clearance of the bearing or the internal clearance (initial clearance) represents the rating of a bearing before mounting it on a shaft or inside of the housing case. The clearance of a bearing can be intended both in a radial sense as well as an axial sense when the movement of the free ring is in the radial sense we say radial clearance while we say axial clearance if the movement is axial. The radial clearance determines the average rating of the various measurements of the total movement on a plain which is perpendicular to the axis of the bearing. Such movement is typical of one of the rings of the bearing (the other is fixed) during the rolling in various angular directions both with respect to the

rotante che a quello fisso e a diverse posizioni angolari della serie di sfere, rispetto agli anelli stessi.

Visti i diversi coefficienti di giuoco richiesti, i cuscinetti radiali possono essere costruiti secondo vari gruppi di giuoco iniziale. Di norma, i cuscinetti a sfere sono costruiti con giuoco radiale normale CN, che, ad impieghi comuni alla maggior parte dei casi, forniscono parametri soddisfacenti di funzionamento. Il giuoco radiale viene evidenziato con l'aggiunta alla sigla del cuscinetto della designazione della classe di precisione (C2, C3, C4, C5), mentre ai cuscinetti costruiti con un giuoco radiale corrispondente al gruppo normale CN non vengono assegnate ulteriori designazioni convenzionali. La durata della vita di un cuscinetto, può essere influenzata da diversi fattori, quali gli accoppiamenti di montaggio, le eventuali differenze di temperature tra l'anello interno e l'anello esterno ecc... da questo si deduce che la scelta del giuoco del cuscinetto è un fattore estremamente importante, perché oltre a determinarne la durata, influisce anche sulla rumorosità, sulle vibrazioni, sulla produzione di calore del cuscinetto. Il giuoco del cuscinetto deve garantirne un buon funzionamento, in particolar modo nel momento in cui potrebbero presentarsi delle contrazioni dell'anello esterno od interno, a seconda dell'applicazione. Le tabelle seguenti forniscono i valori di giuoco radiale.

rotating ring and with respect to the fixed ring and the different angular positions of the series of spheres with respect to the rings themselves.

Considering the different coefficients of clearance required, the radial bearings can be constructed according to various initial groups.

As a norm, spherical bearings are constructed with a normal CN radial clearance that with common use in the majority of cases, supply satisfying functioning parameters. Radial clearance is indicated by an acronym on the bearing with the designation of the precision class (C2, C3, C4, C5), while the bearings constructed with a radial clearance corresponding to the normal group CN are not assigned an ulterior conventional designation.

The life of a bearing can be influenced by different factors accompanied by the mounting and eventual temperature differences between the internal and external ring etc...

From this we deduce that the choice of the clearance of the bearing is an extremely important factor because besides determining the length, it influences the noiselessness, the vibration, the production of heat.

The clearance, of the bearing must guarantee good functioning, in particular, at the moment in which contractions of the external or internal ring may be present depending upon the application. The following table supplies radial clearance ratings.

5.1

TIPOLOGIA GIUOCO RADIALE

TYPES OF RADIAL CLEARANCE

Giuoco Clearance	Significato Meaning	Possibili condizioni operative Possible working conditions
C2	Giuoco radiale dei cuscinetti inferiore a CN <i>Radial clearance of bearings lower than CN</i>	Riduzione rumorosità e vibrazioni <i>Reduction of noisiness and vibrations</i>
CN	Giuoco radiale dei cuscinetti normale <i>Normal radial clearance of bearings</i>	Condizioni normali <i>Normal conditions</i>
C3	Giuoco radiale dei cuscinetti superiore a CN <i>Radial clearance of bearings higher than CN</i>	Montaggio con interferenze su entrambi gli anelli <i>Assembling with interferences on both rings</i>
C4	Giuoco radiale dei cuscinetti superiore a C3 <i>Radial clearance of bearings higher than C3</i>	Errori di montaggio, albero e anello interno riscaldati <i>Assembling mistakes, shaft and inner rings heated</i>
C5	Giuoco radiale dei cuscinetti superiore a C4 <i>Radial clearance of bearings higher than C4</i>	Albero riscaldato e alloggiamento raffreddato <i>Heated shaft and cooled housing</i>

Cuscinetti con foro cilindrico e conico - *Cylindrical and conical bore bearings*

GIUOCO INTERNO RADIALE (ISO 9628:2006)
Radial Internal Clearance (ISO 9628:2006)

Diametro d Diameter d		Diametro d Diameter d	Gruppo N (CN) Group N (CN)		Gruppo 3 (C3) Group 3 (C3)		Diametro d Diameter d		Diametro d Diameter d	Gruppo N (CN) Group N (CN)		Gruppo 3 (C3) Group 3 (C3)													
mm	polici inches		min	max	min	max	mm	polici inches		min	max	min	max												
		mm	µm		µm				mm	µm		µm													
12	-	40	10	25	18	33	50,8	2	100	18	43	38	61												
12,7	1/2																								
14,288	9/16																								
15	-																								
15,875	5/8																								
17	-																								
17,462	11/16																								
19,05	3/4	40	12	28	20	36	58,738	2 5/16	110	18	43	38	61												
20	-																								
20,638	13/16	52	12	28	23	41	60,325	2 3/8	120	20	51	46	71												
22,225	7/8																								
23,812	15/16																								
25	-																								
25,4	1																								
26,988	1 1/16																								
28,575	1 1/8																								
30	-	62	13	33	28	46	70	-	130	24	58	53	84												
30,162	1 3/16																								
31,75	1 1/4																								
31,75	1 1/4																								
33,338	1 5/16																								
34,925	1 3/8																								
35	-													72	14	36	30	51	76,2	3	140	24	58	53	84
36,512	1 7/16																								
38,1	1 1/2																								
39,688	1 9/16																								
40	-	80	14	36	30	51	79,375	3 1/8	150	24	58	53	84												
41,275	1 5/8																								
42,862	1 11/16																								
44,45	1 3/4																								
45	-													85	14	36	30	51	80,962	3 3/16	160	24	58	53	84
46,038	1 13/16																								
47,625	1 7/8																								
49,212	1 15/16																								
50	-	90	14	36	30	51	82,55	3 1/4	170	24	58	53	84												
50,8	2																								
50,8	2																								
50,8	2	90	14	36	30	51	85,725	3 3/8	180	24	58	53	84												
52,388	2 1/16																								
53,975	2 1/8																								
55	-																								
55,562	2 3/16																								
57,15	2 1/4																								
58,738	2 5/16																								
60	-	110	12	28	20	36	60,325	2 3/8	125	20	51	46	71												
61,912	2 7/16																								
63,5	2 1/2																								
65	-																								
66,675	2 5/8																								
68,262	2 11/16																								
69,85	2 3/4																								
70	-	120	12	28	23	41	66,675	2 5/8	130	20	51	46	71												
71,438	2 13/16																								
73,025	2 7/8																								
74,612	2 15/16																								
75	-																								
76,2	3																								
79,375	3 1/8																								
80	-	130	12	28	23	41	68,262	2 11/16	140	20	51	46	71												
71,438	2 13/16																								
73,025	2 7/8																								
74,612	2 15/16																								
75	-																								
76,2	3																								
79,375	3 1/8																								
80	-	140	13	33	28	46	79,375	3 1/8	150	24	58	53	84												
80,962	3 3/16																								
82,55	3 1/4																								
85	-																								
85,725	3 3/8																								
87,312	3 7/16																								
88,9	3 1/2																								
88,9	3 1/2	150	13	33	28	46	80,962	3 3/16	160	24	58	53	84												
90	-																								
93,662	3 11/16																								
95	-																								
100	-																								
100,012	3 15/16																								
101,6	4																								
101,6	4	160	14	36	30	51	82,55	3 1/4	170	24	58	53	84												
82,55	3 1/4																								
85,725	3 3/8																								
87,312	3 7/16																								
88,9	3 1/2																								
88,9	3 1/2																								
90	-																								
93,662	3 11/16																								
95	-	170	14	36	30	51	85,725	3 3/8	180	24	58	53	84												
87,312	3 7/16																								
88,9	3 1/2																								
88,9	3 1/2																								
90	-																								
93,662	3 11/16																								
95	-																								
100	-	180	14	36	30	51	87,312	3 7/16	190	24	58	53	84												
88,9	3 1/2																								
88,9	3 1/2																								
90	-																								
93,662	3 11/16																								
95	-																								
100	-																								
100,012	3 15/16																								
101,6	4																								

GIUOCO INTERNO RADIALE (ISO 5753-1:2009)
Radial Internal Clearance (ISO 5753-1:2009)

Diametro d Diameter d mm		Gr µm	
		C5	
>	≤	min.	max.
12	18	25	45
18	24	28	48
24	30	30	53
30	40	40	64
40	50	45	73
50	65	55	90
65	80	65	105
80	100	75	120
100	120	90	140
120	140	105	160

Il processo di lubrificazione, ha il compito principale di evitare che vi possa essere eccessivo attrito tra le sfere, le piste di rotolamento e le gabbie, ridurre entro certi limiti la rumorosità di funzionamento, assicurare ai cuscinetti protezione dalla corrosione, oltre a diminuire anche l'eventuale attrito delle tenute. I supporti **ISB**[®] sono lubrificati con grassi che mantengono le proprie caratteristiche nel tempo, in condizioni normali d'esercizio. Qualora le condizioni d'esercizio lo richiedessero (condizioni esterne sfavorevoli, innalzamento della temperatura, aumento dei giri del cuscinetto), bisognerebbe procedere con ulteriori lubrificazioni, per consentire al cuscinetto di operare sempre nelle condizioni più favorevoli. Le tabelle riportate a seguito indicano quelli che sono i valori orientativi per i periodi di lubrificazione dei supporti ri-lubrificabili. Occorre precisare che esistono anche dei supporti esenti da manutenzione, di seguito esplicitati.

*The lubrication process is meant principally to avoid excessive wear between the sphere, the rolling track and the cage to reduce to certain limits the noise level of functioning, assure the protection of the bearing against corrosion and furthermore to diminish eventual wear from the seal. **ISB**[®] housings are lubricated with grease that maintains its characteristics over time during normal exercise conditions.*

When conditions require (external unfavourable conditions, increased temperature, increased rounds of the bearing), an ulterior greasing should be done in order to permit the bearing to always operate in more favourable conditions. The following table indicates what the guideline ratings are for the periods of lubrication of housings which can be lubricated again. We should note that some housings exist which do not require maintenance and this is explained as follows.

6.1
SUPPORTI ESENTI DA MANUTENZIONE
MAINTENANCE-FREE BEARING UNITS

I supporti **ISB**[®] esenti da manutenzione, sono unità pronte al montaggio. I cuscinetti utilizzati in questo tipo di supporto contengono una tipologia di grasso d'elevata qualità, a base di litio saponificato, che ne consente un funzionamento continuo a temperature che possono variare dai -30°C a +110°C. Il sistema di tenuta garantisce ai cuscinetti di essere perfettamente protetti da eventuali agenti esterni inquinanti (polvere, umidità, fluidi vari) e di prevenire la fuoriuscita del grasso. La rotazione stessa dell'albero consente la circolazione del grasso e la lubrificazione stessa all'interno del cuscinetto si mantiene per un lungo periodo. I principali vantaggi nell'utilizzo di supporti esenti da manutenzione sono raggruppabili con quanto sotto riportato:

***ISB**[®] housings which are exempt from maintenance are units which are ready to be mounted. The bearings used in this type of housing contain a high quality type of grease made of saponified lithium which allows the functioning to continue at temperatures which vary from -30°C to +110°C. The sealing system guarantees that the bearings are perfectly protected from eventual external pollutants (dust, humidity, various fluids) and it prevents the grease from exiting. The rotation of the shaft itself permits the grease to circulate and the lubrication itself inside the bearing maintains itself for a long period. The main advantages of using these housings is that they are exempt for maintenance and are regrouped as reported below:*

- maggior resistenza ad eventuali infiltrazioni d'agenti inquinanti esterni
- mancanza di dispersioni del grasso utilizzato per la lubrificazione
- unità compatta, perché non vi sono dispositivi di lubrificazione
- risparmio in termini di tempo e costi di manutenzione
- *increased resistance to eventual infiltration from pollutants*
- *no dispersion of grease used to lubricate*
- *compact units because there are no lubrication devices*
- *savings in terms of time and the expense of maintenance*

6.2

SUPPORTI RI-LUBRIFICABILI

RE-GREASEABLE BEARING UNITS

I supporti **ISB®** nelle versioni in ghisa ed in acciaio inox possono essere forniti con apposito ingrassatore che consente periodicamente d'effettuare la ri-lubrificazione del cuscinetto. Il foro dove è posizionato l'ingrassatore può creare un indebolimento della struttura del supporto, anche se da studi effettuati, la posizione del foro è posta in modo tale da rendere minimo l'effetto sopra citato. In condizioni normali è preferibile l'utilizzo di supporti esenti da manutenzione, anche se vi sono comunque applicazioni dove risulta indispensabile l'utilizzo di supporti ri-lubrificabili, come nei casi citati di seguito:

- utilizzo in condizioni estremamente critiche, ove non sia possibile l'utilizzo di ulteriori dispositivi di chiusura (coperchi di protezione)
- utilizzo su macchinari che lavorano ad intermittenza e dove sono presenti agenti inquinanti esterni
- utilizzo in casi dove la rotazione risulta elevata e si possono avere problemi di rumorosità
- utilizzo del supporto con temperature superiori ai +140°C

In condizioni normali d'utilizzo dei supporti **ISB®** la quantità di grasso presente nel cuscinetto è sufficiente per tutta la durata della vita del supporto. Con il verificarsi di condizioni esterne sfavorevoli, come elevate variazioni termiche, numero di giri più elevati, sarà indispensabile valutare adeguatamente questi fattori perché possono notevolmente influire sugli intervalli di lubrificazione.

*The **ISB®** housing units in the cast iron version and in the stainless steel version can be supplied with the necessary lubricator which permits periodic re-greasing of the bearings. The bore where the greaser is positioned can create a weakness in the structure of the housing, even if studies performed, the position of the bore is located in such a way as to render the effects of the above mentioned minimal. In normal conditions it is preferable to use housings which are exempt from maintenance. Even so, there are, in any case, some applications where the use of re-grease bearings is indispensable, as in the case cited below:*

- *use in extremely critical conditions, where it is not possible to use ulterior closure devices (protective covers)*
- *use on machines that work at intermittence and where external pollutant agents are present.*
- *use in cases where the number of rotations are elevated and the may be noise problems.*
- *use when temperatures are above +140° C.*

***ISB®** housing units used in normal conditions, contain a quality grease inside the bearing which is sufficient for all of the life of the bearing. As unfavourable external conditions such as elevated thermal variations, the number of rounds increased, are verified it will be indispensable to evaluate adequately these factors because the can notably influence the lubrication intervals.*

6.3

PERIODICITÀ DELLA LUBRIFICAZIONE

PERIODICITY OF LUBRICATION

I valori, riportati nella sotto indicata tabella, sono relativi agli intervalli di lubrificazione, per un funzionamento approssimativo di 8 ore giornaliere.

The ratings, indicated in the table below, are relative to the intervals of lubrication for functioning approximately 8 hours per day.

Temperatura Temperature	Condizioni d'impiego - Working conditions			Cuscinetto Bearing	Grasso Grease
	Ordinarie Normal	Polvere Dust	Polvere ed umidità Dust and damp		
50°C ➤ 50°C 70°C ➤ 70°C 70°C ➤ 100°C	360/720 giorni/days 360 giorni/days 180 giorni/days	360 giorni/days 120 giorni/days 60 giorni/days	120 giorni/days 30 giorni/days 15 giorni/days	Normale Normal	Litio Lithium
100°C ➤ 120°C 120°C ➤ 150°C	60 giorni/days 15 giorni/days	15 giorni/days 5 giorni/days	5 giorni/days 2 giorni/days	Termoresistente Heat-resistant	Calcio Calcium
150°C ➤ 180°C 180°C ➤ 200°C	7 giorni/days 3 giorni/days	2 giorni/days 1 giorno/day	1 giorno/day 1 giorno/day	Termoresistente Heat-resistant	Speciale Special

I supporti possono essere ri-lubrificati attraverso l'apposito ingrassatore (tipo a sfera), che si trova sulla parte esterna del supporto. Il grasso viene inserito gradualmente nell'ingrassatore (1) ed attraverso un canaletto (2) che si trova nella parte interna del supporto raggiunge due fori (3) che permettono l'ingresso del grasso nel cuscinetto. Si prega di prestare sempre molta attenzione a quanto segue:

- evitare l'ingrassaggio al primo montaggio
- non utilizzare mai olio per la lubrificazione
- utilizzare sempre il grasso raccomandato
- pulire bene l'ingrassatore da eventuali impurità
- inserire il grasso in maniera graduale e lenta, facendo possibilmente ruotare l'albero
- non introdurre mai quantità eccessive di grasso (potrebbe comprometterne il funzionamento)
- se il cuscinetto è stato smontato, prestare particolare attenzione a quando viene rimontato, in modo tale che la parte prolungata dell'anello interno sporgente (4) sia dallo stesso lato dell'ingrassatore, perché solo in questa posizione è possibile la ri-lubrificazione del supporto.

The housings can be re-lubricated using the greaser supplied for that purpose (sphere type), which can be found on the external part of the housing. The grease is inserted gradually in the greaser (1) and using the small canal (2) which can be found in the internal part of the housing, reach two holes (3) which permit the entry of the grease into the bearing. We recommend that careful attention be given to the following:

- *avoid using grease when first mounting*
- *do not ever use oil to lubricate*
- *always use the grease recommended*
- *clean the greasing tool well from eventual impurities*
- *insert the grease in a gradual and slow manner making the shaft rotate if possible*
- *never introduce excessive quantities of grease (they could compromise the functioning)*
- *if the bearing has been dismantled, give careful attention to remounting so that the prolonged part of the internal ring which sticks out (4) is from the same side as the greaser because this is the only position in which it is possible to re-lubricate the housing*

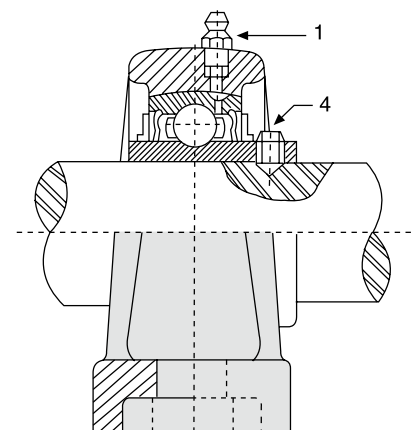
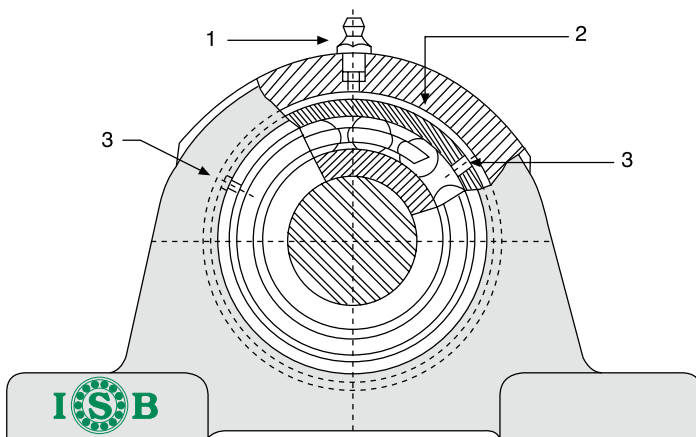

6.5

QUANTITÀ DI GRASSO

GREASE QUANTITY

Normalmente i cuscinetti per supporti **ISB®** sono riempiti circa al 30-35%, percentuale adatta per la maggior parte delle applicazioni più comuni. Se i cuscinetti fossero riempiti con una quantità maggiore, questo provocherebbe una fuoriuscita del grasso, ed anche in virtù della resistenza che si verrebbe a creare, ci sarebbe un effetto di surriscaldamento. Nelle lubrificazioni periodiche si consiglia di attenersi quanto più alla quantità di grasso indicata nella sotto riportata tabella. Per impieghi a basse velocità i valori riportati in tabella possono anche aumentare, non oltre il doppio di quanto indicato.

*Normally the bearings for the **ISB®** housings are filled to 30-35%, the suitable percentage for most common applications.*

If the bearings were to be filled with a larger quantity, this would provoke the grease to overflow and also with resistance that would be created there would be an overheating effect.

When lubricating periodically, it is advisable to use the quantities of grease indicated in the table below.

For low speed uses, the values in the table can even increase but not more than double the amount indicated.

Tipologia di cuscinetto Bearing type			Quantità (g) Quantity (g)
UC 201	-	-	1,6
UC 202	-	-	1,6
UC 203	-	-	1,6
UC 204	-	-	1,6
UC 205	-	UK 205	1,6
UC 206	UCX 05	UK 206	3,1
UC 207	UCX 06	UK 207	4
UC 208	UCX 07	UK 208	5
UC 209	UCX 08	UK 209	5,7
UC 210	UCX 09	UK 210	6,7
UC 211	UCX 10	UK 211	8,6
UC 212	UCX 11	UK 212	11,7
UC 213	UCX 12	UK 213	13,5
UC 214	UCX 13	UK 214	16,2
UC 215	UCX 14	UK 215	18
UC 216	UCX 15	UK 216	22,5
UC 217	UCX 16	UK 217	27,5
UC 218	UCX 17	UK 218	35
-	UCX 18	-	47
-	UCX 20	-	67
-	-	-	-

Tipologia di cuscinetto Bearing type		Quantità (g) Quantity (g)
UC 305	UK 305	4
UC 306	UK 306	5,4
UC 307	UK 307	7,3
UC 308	UK 308	9,5
UC 309	UK 309	11,9
UC 310	UK 310	16,1
UC 311	UK 311	21
UC 312	UK 312	26,5
UC 313	UK 313	31,5
UC 314	UK 314	40
UC 315	UK 315	47,5
UC 316	UK 316	55,5
UC 317	UK 317	65
UC 318	UK 318	76
UC 319	UK 319	91,5
UC 320	UK 320	116,5
UC 321	UK 321	135
UC 322	UK 322	164
UC 324	UK 324	196
UC 326	UK 326	242
UC 328	UK 328	288,5

In linea di massima, quasi tutti i supporti **ISB**[®] sono forniti con apposito ingrassatore in ottone, tipo standard (su richiesta anche zincato o in acciaio inox). Per poter effettuare l'ingrassaggio, sarà necessario utilizzare l'apposito attrezzo. Qualora vi fossero delle necessità particolari d'applicazione è possibile fornire anche altri tipi di ingrassatori, come riportato nei seguenti disegni.

Most **ISB**[®] housings are furnished with the right grease nipple in brass as a standard type (upon request also zinc or stainless steel plated) In order to carry out greasing, it will be necessary to use the proper tool. Should there be necessity for a particular application it is possible to supply other types of grease nipple as can be seen in the following diagrams.



Ottone - Zincati - Acciaio inox
 Brass - Galvanized - Stainless steel

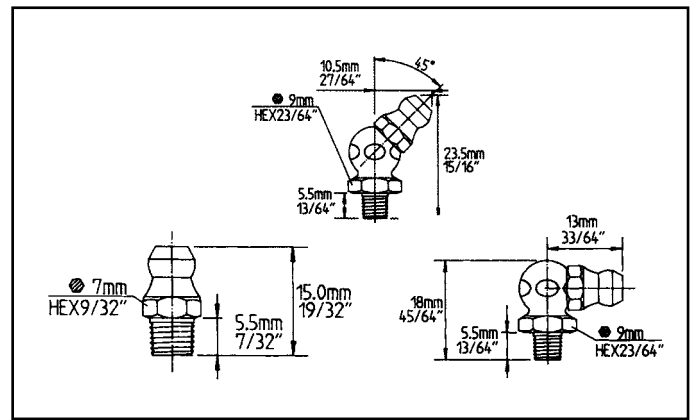

Tipo standard - Standard type

Disponibile solo su richiesta - Available on request

6.7

TABELLA DEI LUBRIFICANTI

TABLES OF LUBRICANTS

I lubrificanti per cuscinetti utilizzati nei supporti ISB®, dovranno rispondere ai seguenti requisiti:

- essere stabili, sia a livello fisico che chimico
- essere privi di corpi estranei provenienti da componenti meccanici (quali abrasivi, sostanze metalliche ecc...)
- garantire un coefficiente minimo d'attrito
- avere una buona capacità lubrificante

La seguente tabella, esplica quelli che sono i lubrificanti comunemente utilizzati nonché le loro principali caratteristiche.

The lubricants for bearings used in ISB® housings should respond to the following requirements:

- be stable, both on a physical as well as a chemical level
- be exempt foreign bodies originating from mechanical components (abrasives, metallic substances etc...)
- guarantee a minimum coefficient of rubbing
- have a good lubricating capacity

The following table explains which are the common lubricants used as well as their principle characteristics.

Marca e tipo Brand name	Grasso base Basic type grease	Temperatura d'esercizio Operating temperature	Caratteristiche Characteristics
Exxon Beacon 325	Grasso sintetico Synthetic grease	-55 ➤ +120°C	Grasso generico General grease
Chevron SRI-2	Grasso minerale Mineral grease	-35 ➤ +180°C	Indicato alle alte temperature con buona resistenza all'acqua High temperature range with good water resistance
Shell Alvania 2	Grasso minerale Mineral grease	-35 ➤ +120°C	Lunga durata Long life
DuPont Krytox 240AC (Mil-G-27617)	Grasso fluorato Fluorinate grease	-35 ➤ +290°C	Indicato per altissime temperature. Non perde le proprietà lubrificanti (costo elevato) High temperature stability with good lubricating properties and (very high price)
Shell Dolium R	Grasso di petrolio Petroleum grease	-40 ➤ +150°C	Resistente alla corrosione ed all'acqua Good corrosion resistance and water washout properties
KYODO SRL	Grasso sintetico Synthetic grease	-40 ➤ +150°C	Bassa rumorosità e bassi carichi Low noise and low torque applications
Mobil HP	Litio Lithium complex	-30 ➤ +110°C	Resistente alla corrosione ed alle vibrazioni, velocità moderate Vibration, moderate speeds and good corrosion resistance

I supporti **ISB**® normalmente vengono forniti già montati e solitamente confezionati singolarmente. Occorre prestare attenzione nel momento dell'apertura della confezione, che non vadano persi eventuali accessori aggiunti, come ad esempio chiavi ed ingrassatori. I supporti **ISB**® sono agevolmente montabili fin dall'inizio, occorre comunque prestare attenzione a quanto sotto riportato, per consentire al supporto di avere una normale vita d'esercizio:

- assicurarsi che la superficie dove viene montato il supporto sia sufficientemente rigida e piana
- evitare disallineamenti oltre i $\pm 2^\circ$ tra la superficie dove viene montato il supporto e l'asse dell'albero

ISB® bearing units are normally furnished already mounted and singularly packaged. Care should be taken while opening the package so that eventual added accessories such as keys and grease nipple are not lost.

ISB® bearing units are easily to mount without prior know how, it is however important to give attention to the following points in order to have a normal live span of the unit:

- *ascertain that the surface where the unit will be mounted is sufficiently rigid and flat.*
- *avoid misalignments outside of $\pm 2^\circ$ between the surface where the unit is to be mounted and the axis of the shaft.*

7.1
FISSAGGIO CON GRANI
SETSCREWS FIXING

Il fissaggio del cuscinetto all'albero avviene attraverso l'avvitamento di due grani che si trovano sulla superficie del cuscinetto stesso (fig. A). Per razionalizzare tale operazione è consigliabile effettuare quanto segue: appiattire leggermente l'albero nella zona del grano di fissaggio (fig. 1) oppure ricavare un leggero incavo (fig. 2). Nel caso si proceda con l'incavo occorre prestare molta attenzione affinché non vi siano spostamenti assiali che possano deformare il cuscinetto. I grani di fissaggio dovrebbero essere serrati il più possibile, in modo da evitare qualsiasi spostamento dell'anello interno sull'albero. **Si raccomanda di non stringere eccessivamente i grani**, che potrebbero causare una deformazione dell'anello interno, con conseguente deformazione dello stesso e causare uno scorrimento non uniforme. I grani di fissaggio andranno montati seguendo i valori indicati nelle sotto riportate tabelle. Se il cuscinetto dovesse essere soggetto a forti oscillazioni o carichi assiali, è consigliabile ricavare sull'albero uno spallamento (fig. 3) in modo tale da bloccare l'anello interno con un dado contro lo spallamento stesso.

The fixing of the bearing to the shaft takes place using setscrews the are located on the surface of the bearing itself (fig. A). To realize such an operation it is advisable to do the following: flatten slightly the shaft in the zone where the setscrew will be fixed (fig. 1) or hollow out a small cavity (fig. 2). In the case of the cavity, be very careful that there are no axial movements that could deform the bearing.

The setscrews should be tightened as much as possible in such a way as to avoid movement of the ring inside the shaft.

We recommend however not to over tighten or tighten excessively the setscrews however as they could cause a deformation of the internal ring with consequent deformation of the bearing and cause non uniform running.

The setscrews will be mounted according to the values indicated on the table below. If the bearing should be subject to strong oscillations or axel loads, it is advisable to hollow out a support to the shaft in such a way as to block the internal ring with a nut against the support itself.

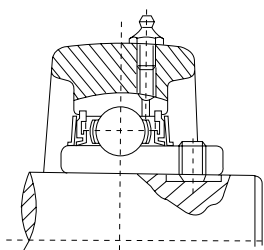

Fig. 1

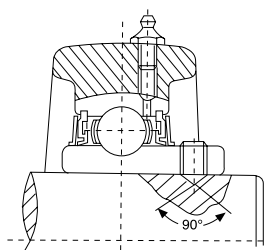

Fig. 2

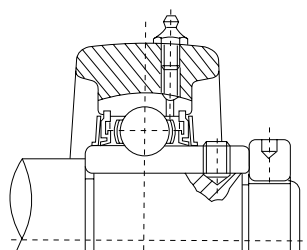

Fig. 3



Fig. A

Coppie di serraggio raccomandate (serie metriche)

Recommended locking torque (metric series)

Tipologia di cuscinetti Bearings type			Sigla grani Designation setscrews	Coppia di serraggio Locking torque Nm (max)
UC 201 UC 206	-	-	M 6x1	3,9
-	-	UC 305 UC 306	M 6x1	4,9
-	UCX 05	-	M 6x1	5,8
UC 207 UC 209	-	-	M 8x1	7,8
-	UCX 06 UCX 08	UC 307	M 8x1	9,8
-	UCX 09	-	M 10x1	16,6
UC 210 UC 213	-	UC 308 UC 309	M 10x1	19,6
-	UCX 10	-	M 10x1	22,5
-	UCX 11 UCX 12	-	M 10x1	24,5
UC 214 UC 218	UCX 13 UCX 16	UC 310 UC 314	M 12x1,5	28
-	UCX 17	-	M 12x1,5	34,3
-	UCX 18	UC 315 UC 316	M 14x1,5	34,3
-	UCX 20	UC 317 UC 319	M 16x1,5	53,9
-	-	UC 320 UC 324	M 18x1,5	58,8
-	-	UC 326 UC 328	M 20x1,5	78,4

Coppie di serraggio raccomandate (serie in pollici)

Recommended locking torque (inches series)

Tipologia di cuscinetti Bearings type			Sigla grani Designation setscrews	Coppia di serraggio Locking torque lbf-inch (max)
UC 201 UC 206	-	-	¼ - 28 UNF	34
-	-	UC 305 UC 306	¼ - 28 UNF	43
-	UCX 05	-	¼ - 28 UNF	52
UC 207 UC 209	-	-	⅝ - 24 UNF	69
-	UCX 06 UCX 08	UC 307	⅝ - 24 UNF	86
-	UCX 09	-	¾ - 24 UNF	147
UC 210 UC 213	-	UC 308 UC 309	¾ - 24 UNF	173
-	UCX 10	-	¾ - 24 UNF	199
-	UCX 11 UCX 12	-	¾ - 24 UNF	216
UC 214 UC 218	UCX 13 UCX 16	UC 310 UC 314	7/16 - 20 UNF	260
-	UCX 17	-	½ - 20 UNF	303
-	UCX 18	UC 315 UC 316	9/16 - 18 UNF	303
-	UCX 20	UC 317 UC 319	5/8 - 18 UNF	477
-	-	UC 320	5/8 - 18 UNF	520
-	-	-	-	-

Coppie di serraggio raccomandate (serie metriche)
Recommended locking torque (metric series)

Tipologia di cuscinetti <i>Bearings type</i>	Sigla grani <i>Designation setscrews</i>	Coppia di serraggio <i>Locking torque Nm (max)</i>
SB - RB 201 SB - RB 203	M 5x08	3,4
SB - RB 204 SB - RB 206	M 6x1	4,4
SB - RB 207 SB - RB 209	M 8x1	6,8

Coppie di serraggio raccomandate (serie in pollici)
Recommended locking torque (inches series)

Tipologia di cuscinetti <i>Bearings type</i>	Sigla grani <i>Designation setscrews</i>	Coppia di serraggio <i>Locking torque lbf-inch (max)</i>
SB - RB 201 SB - RB 203	10 - 32 UNF	34
SB - RB 204 SB - RB 206	¼ - 28 UNF	43
SB - RB 207 SB - RB 209	⅝ - 24 UNF	69

7.2

FISSAGGIO CON BUSSOLA DI TRAZIONE

TAPER ADAPTER FIXING

Quando si vuole procedere al montaggio della bussola di trazione, occorre posizionare il supporto su di una superficie, perfettamente piana (è consigliabile lasciare i bulloni di fissaggio leggermente allentati, per poi stringerli ad operazione avvenuta). Introdurre la bussola in modo tale che la parte conica si trovi quasi al centro del cuscinetto e battere leggermente con un attrezzo, l'intera superficie laterale della bussola. Procedere con l'inserimento della rondella e stringere a fondo la ghiera con apposita chiave. **Si raccomanda di non stringere troppo la ghiera**, perché potrebbero causarsi delle deformazioni, pertanto attenersi ai valori sotto indicati. Al termine delle operazioni sopra elencate, provare la rotazione manuale dell'albero e verificare che ruoti agevolmente.

Once ready to proceed with the mounting of the taper adapter, it is necessary to position the support on a perfectly flat surface (it's a good idea to leave the fixing bolts slightly loose and then tighten them once the operation is complete). Introduce the taper adapter with the conical part nearly at the centre of the bearing and with a tool, hit the entire lateral surface of the bolt lightly. Proceed to insert the washer and tighten completely the ferrule/ring with the proper key.

Attention: over tightening the ferrule could cause deformations therefore, stay within the values indicated below. *At the end of the operation mentioned above, try to manually rotate the shaft and verify that it rotates with ease.*

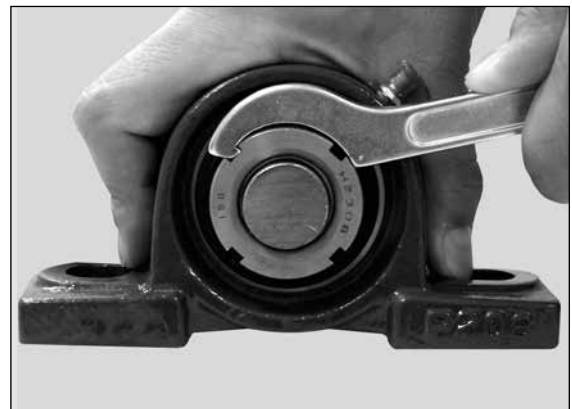
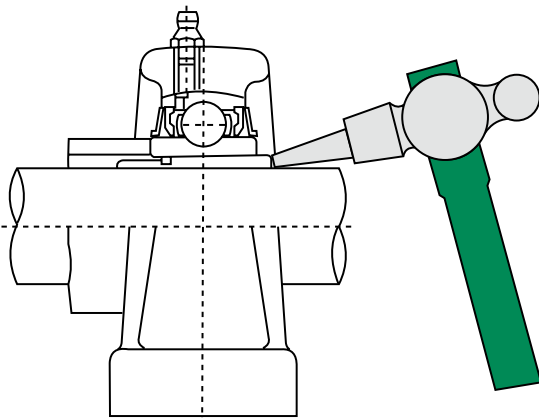

Coppie di serraggio raccomandate (serie metriche)

Recommended locking torque (metric series)

Tipologia di cuscinetti <i>Bearings type</i>	Bussola di trazione <i>Taper adapter</i>	Coppia di serraggio - Locking torque	
		Kg - cm	Nm (max)
UK 205	H 205	254	25
UK 206	H 206	305	30
UK 207	H 207	407	40
UK 208	H 208	509	50
UK 209	H 209	612	60
UK 210	H 210	764	75
UK 211	H 211	1019	100
UK 212	H 212	1325	130
UK 213	H 213	1529	150
UK 215	H 215	1732	170
UK 216	H 216	2038	200
UK 217	H 217	2344	230
UK 218	H 218	2752	270

7.3

FISSAGGIO CON ANELLO ECCENTRICO DI SERRAGGIO

ECCENTRIC COLLAR LOCKING FIXING

Un altro sistema utilizzabile per il fissaggio tra il cuscinetto e l'albero, può avvenire attraverso l'utilizzo di un anello eccentrico di serraggio. In questo caso l'albero e l'anello interno verranno collegati proprio serrando l'anello eccentrico nel senso di rotazione dell'albero. Nel montaggio del supporto con anello eccentrico di serraggio, assicurarsi di compiere correttamente le seguenti operazioni; accertarsi che la superficie dove verrà installato il supporto sia idonea per quell'applicazione; verificare che l'estremità dell'albero sia priva di bave e che la vite di bloccaggio dell'anello eccentrico non fuoriesca dalla parte dell'albero; assicurarsi che il supporto sia ben bloccato alla superficie e che non vi siano possibilità di carichi assiali eccessivi; inserire l'anello eccentrico facendolo girare nel senso di rotazione e con apposito strumento battere in modo da fissare l'anello eccentrico; al termine di queste operazioni serrare la vite di bloccaggio presente sul collare attenendosi ai valori riportati nelle sotto indicate tabelle. Questo sistema di fissaggio non è particolarmente indicato per applicazioni nelle quali gli alberi possono variare il senso di rotazione.

Another system that can be used to fix the bearing and the shaft is to use the eccentric collar locking system.

In this case the shaft and the internal ring actually linked by tightening the eccentric ring in the rotation direction of the shaft. When mounting the eccentric collar locking system support, be sure to correctly perform the task; ascertain that the surface where it will be installed is fit for this application; verify that the edge of the shaft has no metal burr and that the blocking screws of the eccentric ring does not protrude out of the shaft; make sure that the support is securely fastened to the surface and that there is no possibility for excessive axial loads.

Insert the eccentric ring by turning, in the rotation direction, and with the proper tool, strike it so as to fix the eccentric ring.

At the end of this operation, tighten the blocking screw present on the collar staying within the limits indicated on the table below. This fixing system is not particularly indicated for applications in which the shafts can rotate in different directions.

Coppie di serraggio raccomandate (serie metriche)

Recommended locking torque (metric series)

Tipologia di cuscinetti Bearings type			Sigla grani Designation setscrews	Coppia di serraggio Locking torque Nm (max)
HC 204 HC 205	-	SA 201 SA 205	M 6x1	7,8
HC 206 HC 210	HC 303 HC 307	SA 206 SA 211	M 8x1	9,8
HC 211 HC 215	HC 308 HC 312	SA 212	M 10x1	29,4
-	HC 313 HC 314	-	M12x1,5	34,3
-	HC 315 HC 317	-	M 16x1,5	53,9
-	HC 318 HC 320	-	M 20x1,5	78,4

Coppie di serraggio raccomandate (serie in pollici)

Recommended locking torque (inches series)

Tipologia di cuscinetti Bearings type			Sigla grani Designation setscrews	Coppia di serraggio Locking torque lbf-inch (max)
HC 204 HC 205	-	SA 201 SA 205	¼ - 28 UNF	69
HC 206 HC 210	HC 303 HC 307	SA 206	⅝ - 24 UNF	86
HC 211 HC 215	HC 308 HC 312	SA 212	¾ - 24 UNF	260
-	HC 313 HC 314	-	½ - 20 UNF	350
-	HC 315 HC 317	-	⅝ - 18 UNF	520
-	HC 318 HC 320	-	¾ - 16 UNF	700

7.4

MOVIMENTO ASSIALE DOVUTO ALL'ESPANSIONE O AL RESTRINGIMENTO AXIAL MOVEMENT DUE TO EXPANSION AND SHRINKAGE

Succede spesso che in presenza di alcune particolari condizioni di lavoro, l'albero si possa espandere o restringere, e che quindi il cuscinetto si possa muovere.

L'albero della ruota del camion per esempio (mozzo), deve essere mosso in direzione assiale al limite: quando l'albero viene utilizzato a temperature elevate, l'espansione termica fa sì che lo stesso diventi più largo e lungo.

Se i cuscinetti sono tutti fissati sull'albero si verifica sul cuscinetto un carico assiale straordinario, e anche a causa dell'espansione termica potrebbe verificarsi una rottura del cuscinetto stesso.

Per questa ragione, in presenza di espansioni o restringimenti dell'albero bisogna utilizzare un supporto fisso da un lato e uno mobile dall'altro.

It often happens that in the presence of some particular working conditions, the shaft may expand or shrink and therefore the bearings may move.

The shaft of the wheels of a truck for example, should be moved in the axial direction to the limit: when the shaft is used at high temperatures, thermal expansion takes place and the shaft becomes wider and longer.

If the bearings are all attached to the shaft the bearing will be have an extraordinary axial load and could even break due to the thermal expansion.

This is why, in the presence of an expanding or shrinking shaft, fixed support on one side or a mobile one from the other should be used.

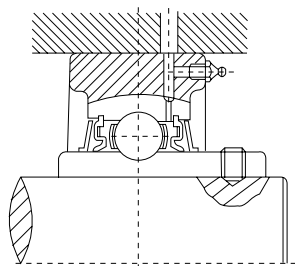

Fig. 1

Fig.1) Come mostrato, è consigliabile utilizzare il tipo di supporto a cartuccia con cuscinetto avente diametro esterno cilindrico, nella stessa maniera che con i soliti cuscinetti. Quando si utilizzano supporti a cartuccia, bisogna prestare attenzione a non causare una deformazione nel momento dell'inserimento. Tutto il corpo della struttura come sopra mostrato, è preparato per essere utilizzato con alte temperature.

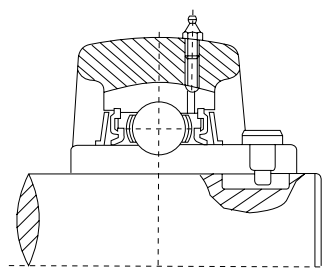

Fig. 2

Fig.2) Ad ogni modo la chiave è lavorata sull'albero, e generalmente al posto dei grani di fissaggio viene utilizzata una vite a testa esagonale. Il movimento assiale causato dall'espansione o dal restringimento dell'albero è regolato da questo.

Fig.1) As shown it is desirable to use a cartridge type bearing with a cylindrical outer diameter in the same manner as with ordinary bearings. When using cartridge type housings, be careful not to cause a deformation at the time of insertion. The complete housing with the above shown structure is prepared for use at high temperatures.

Fig.2) The key is machined on the shaft and a dog point hexagon hollow setscrew is generally used in place of the setscrew. Axial movement due to shaft expansion and shrinkage is in this way regulated.

7.5

SMONTAGGIO DEL SUPPORTO

DISASSEMBLY OF BEARING UNIT

Se per una qualsiasi ragione, si rende necessaria la sostituzione del supporto, occorre ripercorrere le stesse operazioni che si erano effettuate per il montaggio, ma al contrario. È importante prestare attenzione particolare ai seguenti aspetti:

- nel caso il supporto sia stato fissato con i grani di bloccaggio, è importante svitare completamente gli stessi, in modo tale da evitare che nel momento dello smontaggio, i grani non possano in alcun modo strisciare sull'albero segnandolo
- nel caso il supporto sia stato utilizzato con bussola di trazione, occorre sollevare la linguetta della rondella e svitare leggermente la ghiera, dopodiché appoggiando un anello, battere con apposito attrezzo su tutta la superficie della ghiera, fin tanto che non si può estrarre la bussola. Fare molta attenzione a non danneggiare le filettature.

If for any reason, it becomes necessary to substitute the housing, the same operation as was done while mounting must be carried out, but in reverse. Give careful attention to the following aspects:

- If the housing had been fixed with setscrews, it is important to unscrew them completely to keep them from sliding against the shaft while dismantling.
- If the taper adapter has been used to fix the housing, lift the lip of the washer and unscrew slightly the lock nut then while supporting the ring, strike with the proper tool on the surface of the lock nut until the taper adapter can be extracted. Be very careful not to damage the threading.

7.6

SOSTITUZIONE DEL CUSCINETTO

BEARING REPLACEMENT

Se per una qualsiasi ragione, si rendesse necessario sostituire il cuscinetto presente all'interno del supporto, questo non significa che debba essere sostituito anche il corpo del supporto. Per effettuare tale operazione occorre che le viti di bloccaggio siano ben fissate, per non interferire nelle operazioni di sostituzione. Utilizzando un tubo o un attrezzo simile, ed inserendolo all'interno del foro del cuscinetto, quest'ultimo dovrà essere fatto ruotare di circa 90° facendo in modo di estrarlo dalle guide ricavate all'interno della fusione del supporto; dopodiché si procederà nell'operazione inversa per inserire il nuovo cuscinetto.

If for any reason it becomes necessary to substitute the internal bearing of the housing, this does not mean that the housing must also be substituted. To do such an operation the blockage screws are well fixed so as not to interfere with the substitution operation. Using a tube or a similar tool and inserting it inside the bore in the bearing and rotating the bearing about 90° in such a way as to extract it from the guide hollowed out inside the casting of the housing; after which proceed inversely to insert the new bearing.

Durezza ROCKWELL <i>Hardness</i>	Durezza VICKERS <i>Hardness</i>	Durezza BRINNEL <i>Hardness</i>		Durezza ROCKWELL <i>Hardness</i>		Durezza SHORE <i>Hardness</i>
		Scala C <i>Scale C</i>	Sfera Standard <i>Ball</i>	Sfera ¹⁾ <i>Ball¹⁾</i>	Scala A <i>Scale A</i>	
68	940	-	-	85,6	-	97
67	900	-	-	85,0	-	95
66	865	-	-	84,5	-	92
65	832	-	739	83,9	-	91
64	800	-	722	83,4	-	88
63	772	-	705	82,8	-	87
62	746	-	688	82,3	-	85
61	720	-	670	81,8	-	83
60	697	-	654	81,2	-	81
59	674	-	634	80,7	-	80
58	653	-	615	80,1	-	78
57	633	-	595	79,6	-	76
56	613	-	577	79,0	-	75
55	595	-	560	78,5	-	74
54	577	-	543	78,0	-	72
53	560	-	525	77,4	-	71
52	544	500	512	76,8	-	69
51	528	487	496	76,3	-	68
50	513	475	481	75,9	-	67
49	498	464	469	75,2	-	66
48	484	451	455	74,7	-	64
47	471	442	443	74,1	-	63
46	458	432	432	73,6	-	62
45	446	421	421	73,1	-	60
44	434	409	409	72,5	-	58
43	423	400	400	72,0	-	57
42	412	390	390	71,5	-	56
41	402	381	381	70,9	-	55
40	392	371	371	70,4	-	54
39	382	362	362	69,9	-	52
38	372	353	353	69,4	-	51
37	363	344	344	68,9	-	50
36	354	336	336	68,4	(109,0)	49
35	345	327	327	67,9	(108,5)	48
34	336	319	319	67,4	(108,00)	47
33	327	311	311	66,8	(107,5)	46
32	318	301	301	66,3	(107,0)	44
31	310	294	294	65,8	(106,0)	43
30	302	286	286	65,3	(105,5)	42
29	294	279	279	64,7	(104,5)	41
28	286	271	271	64,3	(104,0)	41
27	279	264	264	63,8	(103,0)	40
26	272	258	258	63,8	(102,5)	38
25	266	253	253	62,8	(101,5)	38
24	260	247	247	62,4	(101,0)	37
23	254	243	243	62,0	100,0	36
22	248	237	237	61,5	99,0	35
21	243	231	231	61,0	98,5	35
20	238	226	226	60,5	97,8	34
(18)	230	219	219	-	96,7	33
(16)	222	212	212	-	95,5	32
(14)	213	203	203	-	93,9	31
(12)	204	194	194	-	92,3	29
(10)	196	187	187	-	90,7	28
(8)	188	179	179	-	89,5	27
(6)	180	171	171	-	87,1	26
(4)	173	165	165	-	85,5	25
(2)	166	158	158	-	83,5	24
(0)	160	152	152	-	81,7	24

¹⁾ al carbonio di tungsteno - tungsten carbon material's

1" = 25,4 mm

Pollici - Inches		Pollici - Inches										
Frazioni Fractions	Decimali Decimals	0"	1"	2"	3"	4"	5"	6"	7"	8"	9"	10"
		Millimetri - Millimetres										
-	-	-	25,4000	50,8000	76,2000	101,6000	127,0000	152,4000	177,8000	203,2000	228,6000	254,0000
1/64	0,015625	0,3969	25,7969	51,1969	76,5969	101,9969	127,3969	152,7969	178,1969	203,5969	228,9969	254,3969
1/32	0,031250	0,7938	26,1938	51,5938	76,9938	102,3938	127,7938	153,1938	178,5938	203,9938	229,3938	254,7938
3/64	0,046875	1,1906	26,5906	51,9906	77,3906	102,7906	128,1906	153,5906	178,9906	204,3906	229,7906	255,1906
1/16	0,062500	1,5875	26,9875	52,3875	77,7875	103,1875	128,5875	153,9875	179,3875	204,7875	230,1875	255,5875
3/64	0,078125	1,9844	27,3844	52,7844	78,1844	103,5844	128,9844	154,3844	179,7844	205,1844	230,5844	255,9844
3/32	0,093750	2,3812	27,7812	53,1812	78,5812	103,9812	129,3812	154,7812	180,1812	205,5812	230,9812	256,3812
7/64	0,109375	2,7781	28,1781	53,5781	78,9781	104,3781	129,7781	155,1781	180,5781	205,9781	231,3781	256,7781
1/8	0,125000	3,1750	28,5750	53,9750	79,3750	104,7750	130,1750	155,5750	180,9750	206,3750	231,7750	257,1750
9/64	0,140625	3,5719	28,9719	54,3719	79,7719	105,1719	130,5719	155,9719	181,3719	206,7719	232,1719	257,5719
5/32	0,156250	3,9688	29,3688	54,7688	80,1688	105,5688	130,9688	156,3688	181,7688	207,1688	232,5688	257,9688
11/64	0,171875	4,3656	29,7656	55,1656	80,5656	105,9656	131,3656	156,7656	182,1656	207,5656	232,9656	258,3656
3/16	0,187500	4,7625	30,1625	55,5625	80,9625	106,3625	131,7625	157,1625	182,5625	207,9625	233,3625	258,7625
11/64	0,203125	5,1594	30,5594	55,9594	81,3594	106,7594	132,1594	157,5594	182,9594	208,3594	233,7594	259,1594
7/32	0,218750	5,5562	30,9562	56,3562	81,7562	107,1562	132,5562	157,9562	183,3562	208,7562	234,1562	259,5562
15/64	0,234375	5,9531	31,3531	56,7531	82,1531	107,5531	132,9531	158,3531	183,7531	209,1531	234,5531	259,9531
1/4	0,250000	6,3500	31,7500	57,1500	82,5500	107,9500	133,3500	158,7500	184,1500	209,5500	234,9500	260,3500
17/64	0,265625	6,7469	32,1469	57,5469	82,9469	108,3469	133,7469	159,1469	184,5469	209,9469	235,3469	260,7469
9/32	0,281250	7,1438	32,5438	57,9438	83,3438	108,7438	134,1438	159,5438	184,9438	210,3438	235,7438	261,1438
19/64	0,296875	7,5406	32,9406	58,3406	83,7406	109,1406	134,5406	159,9406	185,3406	210,7406	236,1406	261,5486
5/16	0,312500	7,9375	33,3375	58,7375	84,1375	109,5375	134,9375	160,3375	185,7375	211,1375	236,5375	261,9375
21/64	0,328125	8,3344	33,7344	59,1344	84,5344	109,9344	135,3344	160,7344	186,1344	211,5344	236,9344	262,3344
11/32	0,343750	8,7312	34,1312	59,5312	84,9312	110,3312	135,7312	161,1312	186,5312	211,9312	237,3312	262,7312
23/64	0,359375	9,1281	34,5281	59,9281	85,3281	110,7281	136,1281	161,5281	186,9281	212,3281	237,7281	263,1281
3/8	0,375000	9,5250	34,9250	60,3250	85,7250	111,1250	136,5250	161,9250	187,3250	212,7250	238,1250	263,5250
25/64	0,390625	9,9219	35,3219	60,7219	86,1219	111,5219	136,9219	162,3219	187,7219	213,1219	238,5219	263,9219
13/32	0,406250	10,3188	35,7188	61,1188	86,5188	111,9188	137,3188	162,7188	188,1188	213,5188	238,9188	264,3188
27/64	0,421875	10,7156	36,1156	61,5156	86,9156	112,3156	137,7156	163,1156	188,5156	213,9156	239,3156	264,7156
7/16	0,437500	11,1125	36,5125	61,9125	87,3125	112,7125	138,1125	163,5125	188,9125	214,3125	239,7125	265,1125
29/64	0,453125	11,5094	36,9094	62,3094	87,7094	113,1094	138,5094	163,9094	189,3094	214,7094	240,1094	265,5094
15/32	0,468750	11,9062	37,3062	62,7062	88,1062	113,5062	138,9062	164,3062	189,7062	215,1062	240,5062	265,9062
31/64	0,484375	12,3031	37,7031	63,1031	88,5031	113,9031	139,3031	164,7031	190,1031	215,5031	240,9031	266,3031
1/2	0,500000	12,7000	38,1000	63,5000	88,9000	114,3000	139,7000	165,1000	190,5000	215,9000	241,3000	266,7000
33/64	0,515625	13,0969	38,4969	63,8969	89,2969	114,6969	140,0969	165,4969	190,8969	216,2969	241,6969	267,0969
17/32	0,531250	13,4938	38,8938	64,2938	89,6938	115,0938	140,4938	165,8938	191,2938	216,6938	242,0938	267,4938
35/64	0,546875	13,8906	39,2906	64,6906	90,0906	115,4906	140,8906	166,2906	191,6906	217,0906	242,4906	267,8906
9/16	0,562500	14,2875	39,6875	65,0875	90,4875	115,8875	141,2875	166,6875	192,0875	217,4875	242,8875	268,2875
37/64	0,578125	14,6844	40,0844	65,4844	90,8844	116,2844	141,6844	167,0844	192,4844	217,8844	243,2844	268,6844
19/32	0,593750	15,0812	40,4812	65,8812	91,2812	116,6812	142,0812	167,4812	192,8812	218,2812	243,6812	269,0812
39/64	0,609375	15,4781	40,8781	66,2781	91,6781	117,0781	142,4781	167,8781	193,2781	218,6781	244,0781	269,4781
5/8	0,625000	15,8750	41,2750	66,6750	92,0750	117,4750	142,8750	168,2750	193,6750	219,0750	244,4750	269,8750
41/64	0,640625	16,2719	41,6719	67,0719	92,4719	117,8719	143,2719	168,6719	194,0719	219,4719	244,8719	270,2719
21/32	0,656250	16,6688	42,0688	67,4688	92,8688	118,2688	143,6688	169,0688	194,4688	219,8688	245,2688	270,6688
43/64	0,671875	17,0656	42,4656	67,8656	93,2656	118,6656	144,0659	169,4656	194,8656	220,2656	245,6656	271,0656
11/16	0,687500	17,4625	42,8625	68,2625	93,6625	119,0625	144,4625	169,8625	195,2625	220,6625	246,0625	271,4625
45/64	0,703125	17,8594	43,2594	68,6594	94,0594	119,4594	144,8594	170,2594	195,6594	221,0594	246,4594	271,8594
23/32	0,718750	18,2562	43,6562	69,0562	94,4562	119,8562	145,2562	170,6562	196,0562	221,4562	246,8562	272,2562
47/64	0,734375	18,6531	44,0531	69,4531	94,8531	120,2531	145,6531	171,0531	196,4531	221,8531	247,2531	272,6531
3/4	0,750000	19,0500	44,4500	69,8500	95,2500	120,6500	146,0500	171,4500	196,8500	222,2500	247,6500	273,0500
49/64	0,765625	19,4469	44,8469	70,2469	95,6469	121,0469	146,4469	171,8469	197,2469	222,6469	248,0469	273,4469
25/32	0,781250	19,8438	45,2438	70,6438	96,0438	121,4438	146,8438	172,2438	197,6438	223,0438	248,4438	273,8438
51/64	0,796875	20,2406	45,6406	71,0406	96,4406	121,8406	147,2406	172,6406	198,0406	223,4405	248,8406	274,2406
13/16	0,812500	20,6375	46,0375	71,4375	96,8375	122,2375	147,6375	173,0375	198,4375	223,8375	249,2375	274,6375
53/64	0,828125	21,0344	46,4344	71,8344	97,2344	122,6344	148,0344	173,4344	198,8344	224,2344	249,6344	275,0344
27/32	0,843750	21,4312	46,8312	72,2312	97,6312	123,0312	148,4312	173,8312	199,2312	224,6312	250,0312	275,4312
55/64	0,859375	21,8281	47,2281	72,6281	98,0281	123,4281	148,8281	174,2281	199,6281	225,0281	250,4281	275,8281
7/8	0,875000	22,2250	47,6250	73,0250	98,4250	123,8250	149,2250	174,6250	200,0250	225,4250	250,8250	276,2250
57/64	0,890625	22,6219	48,0219	73,4219	98,8219	124,2219	149,6219	175,0219	200,4219	225,8219	251,2219	276,6219
29/32	0,906250	23,0188	48,4188	73,8188	99,2188	124,6188	150,0188	175,4188	200,8188	226,2188	251,6188	277,0188
59/64	0,921875	23,4156	48,8156	74,2156	99,6156	125,0156	150,4156	175,8156	201,2156	226,6156	252,0156	277,4156
15/16	0,937500	23,8125	49,2125	74,6125	100,0125	125,4125	150,8125	176,2125	201,6125	227,0125	252,4125	277,8125
61/64	0,953125	24,2094	49,6094	75,0094	100,4094	125,8094	151,2094	176,6094	202,0094	227,4094	252,8094	278,2094
31/32	0,968759	24,6062	50,0062	75,4062	100,8062	126,2062	151,6062	177,0062	202,4062	227,8062	253,2062	278,6062
63/64	0,984375	25,0031	50,4031	75,8031	101,2031	126,6031	152,0031	177,4031	202,8031	228,2031	253,6031	279,0031

Tipologia Type	EUROPA - EUROPE				ASIA - ASIA	
	ISB® Italia - Italy	INA/FAG Germania - Germany	RHP Regno Unito - United Kingdom	SKF Svezia - Sweden	ASAHI Giappone - Japan	FYH Giappone - Japan
Supporti ritti Pillow blocks	UCP 2.., UKP 2.., HCP 2..	RASE, RASES, PASE	NP	SY, SYP, SYJ..TF	UCP, UKP 200	UCP, UKP, NAP 200
	UCLP 2..	-	SL	SYH-X	-	SL 200
	UCP X..	-	MP	-	UCP X00	UCP X00
	UCPH 2.., UKPH 2..	-	-	-	UCPH 200	UCPH 200
	UCPA 2.., UKPA 2.. UP..	SHE -	- -	- -	SYF UP 00	UCPA 200 -
Supporti a flangia Flange units	UCF 2.., UKF 2.., HCF 2..	RCJ, RCJS, PCF	SF, SLF	FY, FYP, FY-X	UCF, UKF 200	UCF 200 SLF 200
	UCF X..	-	MSF	-	UCF X00	UCF X00
	UCFC 2.., UKFC 2.., HCF 2..	-	-	FYC	UCFC, UKFC 200	UCFC 200
	UCFC X..	-	MFC	-	UCFC X00	UCFC X00
	UCFL 2.., UKFL 2.., HCFL 2..	RCJT, RCJTS, PCFT	SFT	FYTB	UCFL 200	UCFL 200
	UCFL X..	-	MSFT	-	UCFL X00	UCFL X00
	UFL..	-	-	-	UFL 00	-
	SAFD 2.. - Sbfd 2..	FLCTE / FLCTEY	-	-	-	-
	SALF 2.. - SBLF 2..	-	-	-	-	ALF-BLF 2
	UCFA 2.., UKFA 2.. UCFB 2.., UKFB 2..	SFT - -	- - -	- - -	- - -	UCFA 200 UCFK 200
Supporti scorrevoli Take-up units	UCT 2.., UKT 2.., HCT 2..	PTUE, RTUES	-	-	UCT 200	UCT 200
	UCT X..	-	-	-	UCT X00	UCT X00
Piastra tenditore Stretch-skid	UCT..	-	-	-	WA	UCTH
Supporti a cartuccia Cylindrical cartridge units	UCC 2.., UKC 2.., HCC 2..	-	-	TU	UCC 200	UCC 200
	UCC X..	-	-	-	UCC X00	UCC X00
Supporti pensili Hanger units	UCECH 2.., UKECH 2..	-	SCHB	-	UCECH 200	UCHA 200
Supporti in lamiera stampata Pressed steel bearing units	BPP..	PB	LPB	SP	BPP	SBPP 200 F
	BPF..	RA, RR	SLFE	F	BPF	SBPF 200
	BPFL..	RAT, RRT	SLFL	FT	BPFL	SBPFL 200
	BPFT..	RATR, RRTR	-	-	BPFT	-
Supporti per agricoltura Agricultural units	ST	-	-	-	-	-
Supporti ritti in due metà Bearing housing	SNG 500	-	-	SNH 500	-	-
	SNG 600	-	-	SNH 600	-	-
	SNL 500	-	-	SNL 500	-	-
	SN 500	-	-	-	-	-
	SN 200	-	-	SNH 200	-	-
	SN 300	-	-	SNH 300	-	-
	SD 3000 SD 3100	- -	- -	- SD 3100	- -	- -
Supporti in plastica Plastic bearing units	UCP 2..	PASE, RASEY	-	-	-	-
	UCF 2..	PCJ, RCJY	-	-	-	-
	UCFL 2..	PCJT, RCJTY	-	-	-	-
	UCECH 2..	-	-	-	-	-
	UCPA 2..	-	-	-	-	-
	UCFB 2..	-	-	-	-	-
	SBP 2	-	-	-	-	-
	SBF 2	-	-	-	-	-
	SBFL 2	-	-	-	-	-
Cuscinetti per supporti Bearings for units	UC2..	KRRB	1000 G	YAR	UC 200	UC 200
	HC 2..	GE..KRRB	-	YEL 200	UG 200	NA 200
	UCX..	-	-	-	UCX 00	UCX 00
	UC 3..	-	-	YEL 300	UC 300	UC 300
	UK 2..	GSE..KRRB	1000 G	YSA 200	UK 200	UK 200
	UK 3..	-	-	YSA 300	UK 300	UK 300
	SER 2..	-	-	-	SER 200	ER 200
	SA 2..	RAE..NPPB	12..EC	YET 200	SA 200	SA 200
	SB 2..	AY..NPPB	-	YAT 200	SB 200	SB 200
	RB 2..	-	-	-	-	RB 200
	SC 2 - CB 2 UO..	2..NPPB -	- -	- -	- -	SC 200 -

La tabella sopra riportata può essere utilizzata quale riferimento generale per l'intercambiabilità dei supporti e cuscinetti ISB® rispetto ad altre marche. Si raccomanda sempre di verificare con attenzione le dimensioni dei prodotti ISB® rispetto agli stessi articoli di altre marche; alcuni hanno identiche dimensioni, mentre altri possono avere dimensioni diverse. I cuscinetti della serie pesante non sono stati citati in questa tabella, ma sono comunque disponibili per le serie: UCP - UCF - UCFS - UCFL - UCT

ASIA - ASIA				AMERICA - AMERICA		
KOYO Giappone - Japan	NACHI Giappone - Japan	NSK Giappone - Japan	NTN Giappone - Japan	FAFNIR Stati Uniti d'America U.S.A.	LINK-BELT Stati Uniti d'America U.S.A.	SEAL-MASTER Stati Uniti d'America U.S.A.
UCP, UKP 200, GAP 1100B	UCP, UKP+H, UGP, BP 200	UCP, UKP, EWP 200	UCP, UK UELPL 200	RAS, LAS	P3-Y200N	NP
SLP 200	UCLP, FGAK 200	UCPLL, EWPLL 200	UCPL 200	RAK, LAK	PL3-Y200N	S-500-M
UCP X00	UCP, UKP+H X00	UCP X00	UCP X00	RAKH, LAKH	-	MP
-	-	UCPH 200	UCPH 200	-	-	-
UCPA 200, UKPA 200	UCPA 200	UCPA 200	UCUP 200	-	-	-
-	-	UBLP 200	UP 00	-	-	-
UCF 200 GFF 1100	UCF, UKF+H, UGF, BF, UCLF 200	UCF, EWFH 200	UCF 200	RCJ, LCJ	F3-Y200N	SF
UCF X00	UCF, UKF+H X00	UCF X00	UCF X00	RCJO, LCJO	-	MSF
UCFC 200	UCFC, UKFC+H, UGFC, BCF 200	UCFC 200	UCFC 200	-	-	-
UCFC X00	UCF, UKFC+H X00	UCFC X00	UCFC X00	RFC	FC3-Y200N	MFC
UCFL 200 UCFL 1100	UCFL, UKFL+H, UGFL, BFL, UCFT 200	UCFL, EWFLH 200	UCFL 200	FCJT, LCJT	FX3-Y200N	SFT
UCFL X00	UCFL, UKFL+H X00	UCFL X00	UCFL X00	-	-	MSFT
-	-	UBLF 200	UFL 00	-	-	-
-	-	-	ASFD 2	-	-	-
-	-	-	-	-	-	-
UCFA 200 UKFA 200	-	UCFA 200	UCFA 200	-	-	-
UCBF 200	UCFK 200	UCFK 200	UCFH 200	-	-	-
UCT 200	UCT, UKT+H, UGT, BT 200	UCT 200	UCT 200	-	-	-
UCT X00	UCT, UKT+H X00	UCT X00	UCT X00	-	-	-
LV-HT	-	WB	UCT	-	-	-
UCC 200	UCC, UKC+H, UGC, BC 200	UCC 200	UCC 200	-	-	-
UCC X00	UCC, UKC+H X00	UCC X00	UCC X00	-	-	-
SCHB 200	ECECH 200	UCEH 200	UCHB 200	-	-	SEHB
SP	BPP	UBPP 200	ASPP 200	PB	-	SSP
PF	BPF	UBPF 200	ASPF 200	RE, RR	MSC1	SSF
PTF	BPFL	UBPFL 200	ASPF 200	RAT, RRT	MST	SSFT
PTFR	BPFT	UBPFT 200	-	RATR, RRTR	MSTR	TSSF
-	-	-	-	-	-	-
-	-	-	-	-	-	-
-	-	-	-	-	-	-
-	-	-	-	-	-	-
-	-	-	-	-	-	-
-	-	-	-	-	-	-
-	-	-	-	-	-	-
-	-	-	-	-	-	-
-	-	-	-	-	-	-
-	-	-	-	-	-	-
-	-	-	-	-	-	-
-	-	-	-	-	-	-
-	-	-	-	-	-	-
-	-	-	-	-	-	-
-	-	-	-	-	-	-
-	-	-	-	-	-	-
UC 200	UC (UCW) 200	UC 200	UC 200	GC1100KRBB	YG 200 N	2-00
-	-	EW 200	UEL 200	G1100KRBB	-	-
UCX 00	UCX 00	UCX 00	UCX 00	GN-KRRB	U300D	3-00
UC 300	UC 300	UC 300	UC 300	-	-	-
UK 200	UK 200	UK 200	UK 200	G-KLLB	YG 200 N	2-00
UK 300	UK 300	UK 300	UK 300	-	-	-
-	SER 200	-	UCS 200	GC-KRRG-2	-	ER
-	KH 200 AE	EN 200	AEL 200	RA..RRB	-	L-00
PB	B	UB 200	AS 200	YA..RRB	-	-
-	-	UR 200	-	-	-	-
CB	-	CS 2.. DDU	CS 2.. LLU	-	-	-
-	-	-	-	-	-	-

The above table should be used as a cross reference for ISB® and other manufacturers of self-aligning bearing units. Please note that some dimensions of the ISB® brand may differ slightly from those of other manufacturers. Heavier duty Pillow Blocks have not been included in this cross reference table. Sizes available are: UCP - UCF - UCFS - UCFL - UCT.

Supporto Housing	Tipologia - Type					
	UC2.. UC3.. UCX..	UK2.. UK3.. UKX..	HC2..	SA2..	SB-RB2..	U0
P	UCP2.. - UCP3.. UCLP2.. - UCPX..	UKP2.. - UKP3.. UKPX..	HCP2..	SAP	SBP	-
F	UCF2.. - UCF3.. UCF53.. - UCFX..	UKF2.. - UKF3.. UKFX..	HCF2..	SAF	SBF	-
FC	UCFC2.. - UCFCX..	UKFC2.. - UKFCX..	HCFC2..	SAFC	SBFC	-
FL	UCFL2.. - UCFL3.. UCFLX..	UKFL2.. - UKFL3.. UKFLX..	HCFL2..	SAFL	SBFL	-
T	UCT2.. - UCT3.. UCTX..	UKT2.. - UKT3.. UKTX..	HCT2..	SAT	SBT	-
C	UCC2.. - UCC3.. UCCX..	UKC2.. - UKC3.. UKCX..	HCC2..	SAC	SBC	-
PH	UCPH2..	UKPH2..	HCPH2..	SAPH	SBPH	-
PA	UCPA2..	UKPA2..	HCPA2..	SAPA	SBPA	-
FA	UCFA2..	UKFA2..	HCFA2..	SAFA	SBFA	-
FB	UCFB2..	UKFB2..	HCFB2..	SAFB	SBFB	-
ECH	UCECH2..	UKECH2..	HCECH2..	SAECH	SBECH	-
LP Alluminio Aluminium	-	-	HCLP2..	SALP	-	UP
LF Alluminio Aluminium	-	-	HCLF2..	SALF2..	-	UFL
FD	-	-	HCFD2..	SAFD2..	SBFD2..	-
LF	-	-	HCLF2..	SALF2..	SBLF2..	-
ST	Supporti agricoli (su richiesta disponibili misure in pollici) - Agricultural bearing units (inches size are available under request)					
PP	BPP..	-	-	BPP-SA2..	BPP-SB2..	-
PF	BPF..	-	-	BPF-SA2..	BPF-SB2..	-
PFL	BPFL..	-	-	BPFL-SA2..	BPFL-SB2..	-
FT	BPFT..	-	-	BPFT-SA2..	BPFT-SB2..	-
SNG-SNL SN-SD	Supporti ritti in due metà - Bearing Housings					
P Plastica Plastic	UCP2..	con cuscinetto UC inox ed in plastica - with plastic or stainless steel UC bearing				
F Plastica Plastic	UCF2..	con cuscinetto UC inox ed in plastica - with plastic or stainless steel UC bearing				
FC Plastica Plastic	UCFC2..	con cuscinetto UC inox ed in plastica - with plastic or stainless steel UC bearing				
FL Plastica Plastic	UCFL2..	con cuscinetto UC inox ed in plastica - with plastic or stainless steel UC bearing				
T Plastica Plastic	UCT2..	con cuscinetto UC inox ed in plastica - with plastic or stainless steel UC bearing				
ECH Plastica Plastic	UCECH2..	con cuscinetto UC inox ed in plastica - with plastic or stainless steel UC bearing				
PA Plastica Plastic	UCPA2..	con cuscinetto UC inox ed in plastica - with plastic or stainless steel UC bearing				
FB Plastica Plastic	UCFB2..	con cuscinetto UC inox ed in plastica - with plastic or stainless steel UC bearing				

Tipo - Type						Pagina Page	
						Supporti <i>Bearing units</i>	44
					<i>Stretch-skid for UCT</i>		
						Supporti in lamiera <i>Pressed steel bearing units</i>	98
						Cuscinetti <i>Bearings</i>	104
						Supporti ritti in due metà <i>Plummer blocks</i>	118
						Supporti flangiati <i>Housings</i>	141
						Supporti in plastica <i>Plastic bearing units</i>	142
					<i>Polypropylene covers</i>		
						Supporti per viti a ricircolo di sfere <i>Supports of ball screws</i>	159

I supporti **ISB** possono essere utilizzati non solamente in condizioni di normale temperatura, ma anche in applicazioni con elevate temperature.

Nei supporti **ISB** per Alta Temperatura (**HT**) viene impiegata una speciale tipologia di tenuta e di grasso, appositamente studiati per resistere oltre ai 100° C, come da tabella sotto riportata.

Nell'utilizzo ad elevata temperatura, è necessario considerare che i supporti presentano un calo del carico massimo ammissibile, e un incremento del giuoco radiale rispetto alle normali condizioni d'impiego.

Lo standard di riferimento per il giuoco radiale dei cuscinetti montati in questi supporti è C5 sia per fori cilindrici che conici. In condizioni di elevato differenziale di temperatura tra l'anello interno e l'anello esterno del cuscinetto, occorre prevedere specifici giuochi radiali.

ISB bearing units may be used not only in normal temperature conditions, but also in high temperature applications.

*ISB bearing units for High Temperature (**HT**) use suitable kind of rubber seal and the grease for specific operating temperature as shown in the table reported below.*

For heat resistance application, it must be taken in consideration the decrease of load rating of the bearings and a larger-than-normal radial internal clearance.

Standard radial internal clearances for High Temperature applications are C5 for both cylindrical and tapered bore bearings.

When temperature gap between the inner and the outer ring of the bearing is extremely large, suitable radial internal clearance must be determined.

Intervalli di impiego

Range of operating temperature

Applicazione <i>Application</i>	Temperatura <i>Temperature</i>	Grasso <i>Grease</i>	Tenuta in gomma <i>Rubber seal</i>	Colore schermo <i>Colour of slinger</i>
Standard <i>Standard</i>	-15 ➤ +100°C	A base di litio <i>Lithium-Base Grease 2</i>	NBR	Nero <i>Black</i>
Alta temperatura <i>High Temperature</i>	Fino a +200 °C <i>Up to +200 °C</i>	Egols-8604	Silicone <i>Silicon rubber</i>	Rosso <i>Red</i>

SUPPORTI

BEARING UNITS



SUPPORTI IN LAMIERA

PRESSED STEEL BEARING UNITS



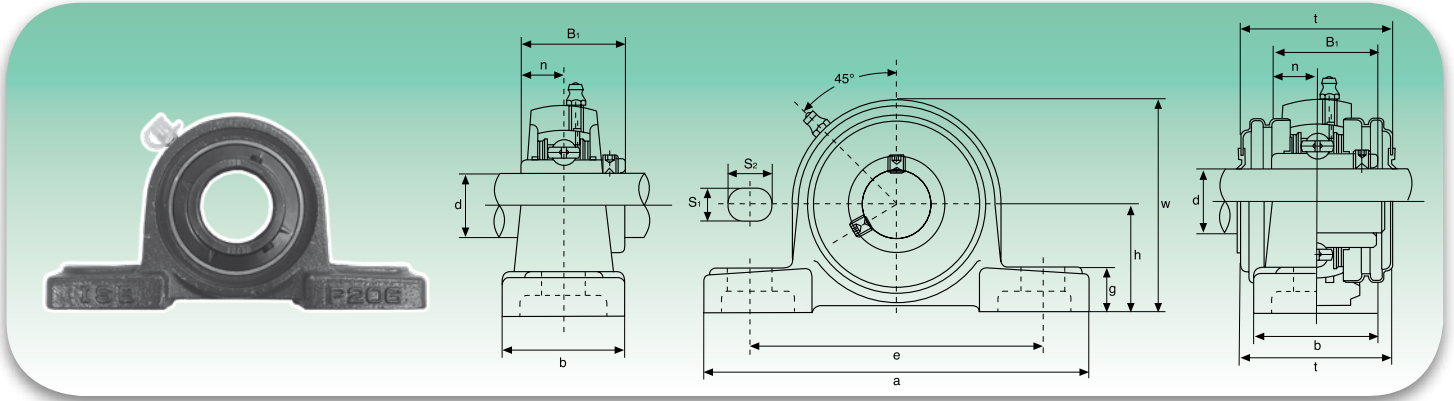

Tipo Type	Dimensioni - Dimensions											Bull. fiss. Bolt Size	Coefficienti di carico (N) Load ratings (N)		Cuscinetto Bearing	Supporto Housing	Peso Weight		
	d	h	a	e	b	S ₁	S ₂	g	w	t	B ₁		n	Dinamico C Dynamic C				Statico C ₀ Static C ₀	kg
	mm/inch												mm/inch						
UCP201	12	30,2	127	95	38	13	19	14	62	44,5	31	12,7	M10	12160	6318	UC201	P203	0,69	
UCP201-8	3/4	1 3/16	5	3 3/4	1 1/2	1/2	3/4	9/16	2 7/16	1 3/4	1,2205	0,500	3/8			UC201-8		0,69	
UCP202	15	30,2	127	95	38	13	19	14	62	44,5	31	12,7	M10	12160	6318	UC202	P203	0,69	
UCP202-9	9/16	1 3/16	5	3 3/4	1 1/2	1/2	3/4	9/16	2 7/16	1 3/4	1,2205	0,500	3/8			UC202-9		0,69	
UCP202-10	5/8	1 3/16	5	3 3/4	1 1/2	1/2	3/4	9/16	2 7/16	1 3/4	1,2205	0,500	3/8			UC202-10		0,69	
UCP203	17	30,2	127	95	38	13	19	14	62	44,5	31	12,7	M10	12160	6318	UC203	P203	0,68	
UCP203-11	1 1/16	1 3/16	5	3 3/4	1 1/2	1/2	3/4	9/16	2 7/16	1 3/4	1,2205	0,500	3/8			UC203-11		0,67	
UCP204	20	33,3	127	95	38	13	19	14	65	44,5	31	12,7	M10	12160	6318	UC204	P204	0,66	
UCP204-12	3/4	1 3/16	5	3 3/4	1 1/2	1/2	3/4	9/16	2 7/16	1 3/4	1,2205	0,500	3/8			UC204-12		0,66	
UCP205	25	36,5	140	105	38	13	19	15	71	48	34,1	14,3	M10			UC205		0,81	
UCP205-13	1 3/16															UC205-13		0,85	
UCP205-14	7/8	1 1/16	5 1/2	4 1/8	1 1/2	1/2	3/4	1 9/32	2 29/32	1 5/16	1,3425	0,563	3/8	13300	7457	UC205-14	P205	0,83	
UCP205-15	1 9/16	1 1/16	5 1/2	4 1/8	1 1/2	1/2	3/4	1 9/32	2 29/32	1 5/16	1,3425	0,563	3/8			UC205-15		0,82	
UCP205-16	1															UC205-16		0,81	
UCP206	30	42,9	165	121	48	17	20	17	84	53	38,1	15,9	M14			UC206		1,24	
UCP206-17	1 1/16															UC206-17		1,27	
UCP206-18	1 1/8	1 11/16	6 1/2	4 3/4	1 7/8	4 3/64	2 5/32	2 1/32	3 5/16	2 5/64	1,5000	0,626	1/2	18525	10735	UC206-18	P206	1,26	
UCP206-19	1 3/16	1 11/16	6 1/2	4 3/4	1 7/8	4 3/64	2 5/32	2 1/32	3 5/16	2 5/64	1,5000	0,626	1/2			UC206-19		1,24	
UCP206-20	1 1/4															UC206-20		1,23	
UCP207	35	47,6	167	127	48	17	20	18	93	59,5	42,9	17,5	M14			UC207		1,58	
UCP207-20	1 1/4															UC207-20		1,64	
UCP207-21	1 5/16	1 7/8	6 9/16	5	1 7/8	4 3/64	2 5/32	4 5/64	3 21/32	2 11/32	1,6890	0,689	1/2	24415	14630	UC207-21	P207	1,61	
UCP207-22	1 3/8															UC207-22		1,58	
UCP207-23	1 7/16															UC207-23		1,55	
UCP208	40	49,2	184	137	54	17	20	18	100	69	49,2	19	M14			UC208		1,89	
UCP208-24	1 1/2	1 15/16	7 1/4	5 13/32	2 1/8	4 3/64	2 5/32	4 5/64	3 15/16	2 23/32	1,9370	0,748	1/2	27645	16910	UC208-24	P208	1,93	
UCP208-25	1 9/16	1 15/16	7 1/4	5 13/32	2 1/8	4 3/64	2 5/32	4 5/64	3 15/16	2 23/32	1,9370	0,748	1/2			UC208-25		1,90	
UCP209	45	54,0	190	146	54	17	20	20	106	69	49,2	19	M14			UC209		2,14	
UCP209-26	1 5/8	2 1/8	7 15/32	5 3/4	2 1/8	4 3/64	2 5/32	2 5/32	4 11/64	2 23/32	1,9370	0,748	1/2	32395	20235	UC209-26	P209	2,24	
UCP209-27	1 11/16															UC209-27		2,20	
UCP209-28	1 3/4															UC209-28		2,14	
UCP210	50	57,2	206	159	60	20	23	21	113	74,5	51,6	19	M16			UC210		2,66	
UCP210-29	1 13/16															UC210-29		2,78	
UCP210-30	1 7/8	2 1/4	8 1/8	6 1/4	2 3/8	2 5/32	2 9/32	5 3/64	4 29/64	2 15/16	2,0315	0,748	5/8	33345	22135	UC210-30	P210	2,73	
UCP210-31	1 15/16															UC210-31		2,68	
UCP210-32	2															UC210-32		2,64	
UCP211	55	63,5	219	171	60	20	23	23	125	76	55,6	22,2	M16			UC211		3,31	
UCP211-32	2															UC211-32		3,46	
UCP211-33	2 1/16	2 1/2	8 5/8	6 47/64	2 3/8	2 5/32	2 9/32	2 9/32	4 59/64	3	2,1890	0,874	5/8	41230	27930	UC211-33	P211	3,40	
UCP211-34	2 1/8															UC211-34		3,35	
UCP211-35	2 3/16															UC211-35		3,29	
UCP212	60	69,8	241	184	70	20	23	25	138	89	65,1	25,4	M16			UC212		4,90	
UCP212-36	2 1/4															UC212-36		5,03	
UCP212-37	2 5/16	2 3/4	9 1/2	7 1/4	2 3/4	2 5/32	2 9/32	6 3/64	5 7/16	3 1/2	2,5630	1,000	5/8	49780	34390	UC212-37	P212	4,95	
UCP212-38	2 3/8															UC212-38		4,88	
UCP212-39	2 7/16															UC212-39		4,81	
UCP213	65	76,2	265	203	70	25	28	27	150	89	65,1	25,4	M20			UC213		5,15	
UCP213-40	2 1/2	3	10 7/16	8	2 3/4	6 3/64	1 3/32	1 1/16	5 29/32	3 1/2	2,5630	1,000	3/4	54340	38095	UC213-40	P213	5,24	
UCP213-41	2 9/16															UC213-41		5,15	
UCP214	70	79,4	266	210	72	25	28	27	156	-	74,6	30,2	M20			UC214		6,20	
UCP214-42	2 5/8															UC214-42		6,41	
UCP214-43	2 1/16	3 3/8	10 15/32	8 17/64	2 27/32	6 3/64	1 3/32	1 1/16	6 9/64	-	2,9370	1,189	3/4	59090	41895	UC214-43	P214	6,31	
UCP214-44	2 3/4															UC214-44		6,21	
UCP215	75	82,6	275	217	74	25	28	28	162	-	77,8	33,3	M20			UC215		7,16	
UCP215-45	2 13/16															UC215-45		7,41	
UCP215-46	2 7/8	3 1/4	10 53/64	8 35/64	2 29/32	6 3/64	1 3/32	1 3/32	6 3/8	-	3,0630	1,311	3/4	64030	45885	UC215-46	P215	7,30	
UCP215-47	2 15/16															UC215-47		7,19	
UCP215-48	3															UC215-48		7,07	
UCP216	80	88,9	292	232	78	25	28	30	174	-	82,6	33,3	M20			UC216		8,10	
UCP216-49	3 1/16															UC216-49		8,28	
UCP216-50	3 3/8	3 1/2	11 1/2	9 1/8	3 1/16	6 3/64	1 3/32	1 3/16	6 27/32	-	3,2520	1,311	3/4	69065	50350	UC216-50	P216	8,15	
UCP216-51	3 3/16															UC216-51		8,02	
UCP217	85	95,2	310	247	83	25	28	32	185	-	85,7	34,1	M20			UC217		9,81	
UCP217-52	3 3/4															UC217-52		10,03	
UCP217-53	3 5/16	3 3/4	12 13/64	9 23/32	3 17/64	6 3/64	1 3/32	1 1/4	7 9/32	-	3,3740	1,343	3/4	79800	58805	UC217-53	P217	9,89	
UCP217-55	3 7/16															UC217-55		9,60	
UCP218	90	101,6	327	262	88	27	30	33	198	-	96	39,7	M22			UC218		11,96	
UCP218-56	3 1/2	4	12 7/8	10 3/16	3 19/32	1 1/16	1 3/16	1 13/64	7 9/64	-	3,7795	1,5630	7/8	91295	67925	UC218-56	P218	12,07	

Disponibile in acciaio inox Supporto: AISI 304 - Cuscinetto: AISI 440C o 420C - Available stainless steel Housing: AISI 304 - Bearing: AISI 440C or 420C
 Disponibile su richiesta con cuscinetto SA (SAP.) - Available under request with SA bearing (SAP.)

HCP2 Serie normale - Standard duty

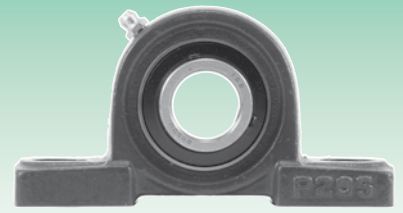
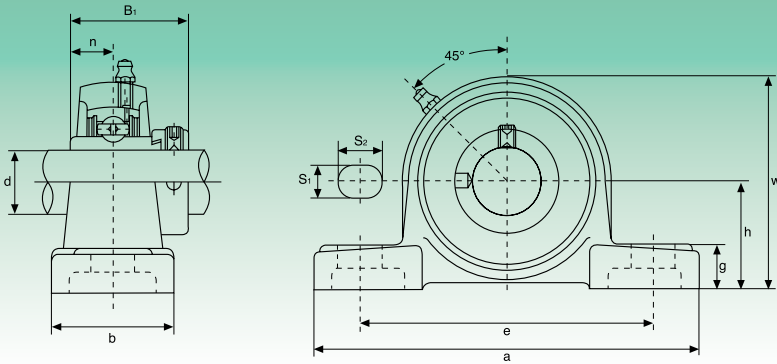

Tipo Type	Dimensioni - Dimensions											Bull. fiss. Bolt Size	Coefficienti di carico (N) Load ratings (N)		Cuscinetto Bearing	Supporto Housing	Peso Weight
	d	h	a	e	b	S ₁	S ₂	g	w	B ₁	n		Dinamico C Dynamic C	Statico C ₀ Static C ₀			
	mm/inch												mm/inch				
HCP204	20	33,3	127	95	38	13	19	14	65	43,7	17,1	M10	12160	6318	HC204	P204	0,73
HCP204-12	1 1/4	1 1/16	5	3 3/4	1 1/2	1/2	3/4	9/16	2 5/16	1,720	0,673	3/8			0,73		
HCP205	25	36,5	140	105	38	13	19	15	71	44,4	17,5	M10	13300	7457	HC205	P205	0,88
HCP205-13	1 9/16														0,93		
HCP205-14	7/8	1 1/16	5 1/2	4 1/8	1 1/2	1/2	3/4	1 9/32	2 25/32	1,748	0,689	3/8			0,92		
HCP205-15	1 1/16														0,90		
HCP205-16	1														0,88		
HCP206	30	42,9	165	121	48	17	20	17	84	48,4	18,3	M14			18525		10735
HCP206-17	1 1/16												1,42				
HCP206-18	1 1/8	1 1/16	6 1/2	4 3/4	1 7/8	4 3/64	2 5/32	2 1/32	3 3/16	1,906	0,720	1/2	1,39				
HCP206-19	1 3/16												1,37				
HCP206-20	1 1/4												1,34				
HCP207	35	47,6	167	127	48	17	20	18	93	51,1	18,8	M14	24415	14630	HC207	P207	1,70
HCP207-20	1 1/4														1,77		
HCP207-21	1 5/16	1 7/8	6 5/16	5	1 7/8	4 3/64	2 5/32	4 5/64	3 21/32	2,012	0,740	1/2			1,73		
HCP207-22	1 3/8														1,70		
HCP207-23	1 1/16														1,67		
HCP208	40	49,2	184	137	54	17	20	18	100	56,3	21,4	M14	27645	16910	HC208	P208	2,04
HCP208-24	1 1/2	1 1/16	7 1/4	5 13/32	2 1/8	4 3/64	2 5/32	4 5/64	3 15/16	2,217	0,843	1/2			2,09		
HCP208-25	1 1/16														2,05		
HCP209	45	54,0	190	146	54	17	20	20	106	56,3	21,4	M14	32395	20235	HC209	P209	2,31
HCP209-26	1 5/8														2,42		
HCP209-27	1 11/16	2 1/8	7 15/32	5 3/4	2 1/8	4 3/64	2 5/32	2 5/32	4 11/64	2,217	0,843	1/2			2,37		
HCP209-28	1 3/4														2,33		
HCP210	50	57,2	206	159	60	20	23	21	113	62,7	24,6	M16	33345	22135	HC210	P210	2,85
HCP210-29	1 13/16														3,00		
HCP210-30	1 7/8	2 1/4	8 1/8	6 1/4	2 3/8	2 5/32	2 9/32	5 3/64	4 29/64	2,469	0,969	3/8			2,94		
HCP210-31	1 15/16														2,88		
HCP210-32	2												2,82				
HCP211	55	63,5	219	171	60	20	23	23	125	71,4	27,8	M16	41230	27930	HC211	P211	3,52
HCP211-32	2														3,72		
HCP211-33	2 1/16	2 1/2	8 5/8	6 47/64	2 3/8	2 5/32	2 9/32	2 9/32	4 59/64	2,811	1,094	5/8			3,64		
HCP211-34	2 1/8														3,57		
HCP211-35	2 3/16														3,49		
HCP212	60	69,8	241	184	70	20	23	25	138	77,8	31	M16	49780	34390	HC212	P212	5,24
HCP212-36	2 1/4														5,40		
HCP212-37	2 5/16	2 3/4	9 1/2	7 1/4	2 3/4	2 5/32	2 9/32	6 3/64	5 7/16	3,063	1,220	5/8			5,31		
HCP212-38	2 3/8														5,26		
HCP212-39	2 7/16														5,13		
HCP213	65	76,2	265	203	70	25	28	27	150	85,7	34,1	M20	54340	38095	HC213	P213	5,71
HCP213-40	2 1/2	3	10 7/16	8	2 3/4	6 3/64	1 3/32	1 1/16	5 29/32	3,374	1,343	3/4			5,81		
HCP213-41	2 9/16												5,70				
HCP214	70	79,4	266	210	72	25	28	27	156	85,7	34,1	M20	59090	41895	HC214	P214	6,70
HCP214-42	2 3/8														6,94		
HCP214-43	2 11/16	3 1/8	10 15/32	8 17/64	2 27/32	6 3/64	1 3/32	1 1/16	6 9/64	3,374	1,343	3/4			6,83		
HCP214-44	2 3/4														6,71		
HCP215	75	82,6	275	217	74	25	28	28	162	92,1	37,3	M20	64030	45885	HC215	P215	7,79
HCP215-45	2 13/16														8,09		
HCP215-46	2 7/8	3 1/4	10 53/64	8 33/64	2 29/32	6 3/64	1 3/32	1 3/32	6 3/8	3,626	1,426	3/4			7,96		
HCP215-47	2 15/16														7,83		
HCP215-48	3														7,69		

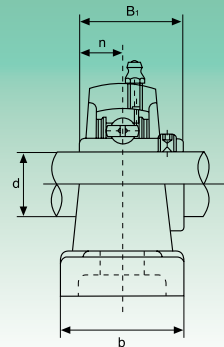
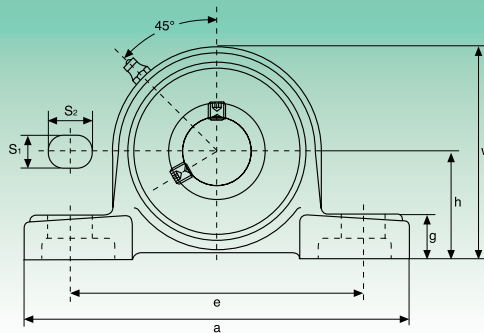
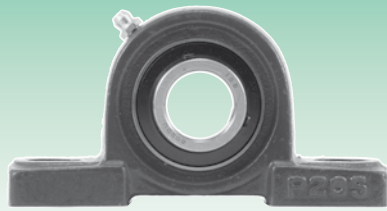

Tipo Type	Dimensioni - Dimensions											Bull. fiss. Bolt Size	Coefficienti di carico (N) Load ratings (N)		Cuscinetto Bearing	Supporto Housing	Peso Weight
	d	h	a	e	b	S ₁	S ₂	g	w	B ₁	n		Dinamico C Dynamic C	Statico C ₀ Static C ₀			
	mm/inch												mm/inch				
UCLP201	12	31,75	127	95	38	13	16	14	64	31	12,7	M10	12160	6318	UC201 UC201-8	LP204	0,69
UCLP201-8	3/4	1 1/4	5	3 3/4	1 1/2	1/2	5/8	9/16	2 3/4	1,2205	0,500	3/8					0,69
UCLP202	15	31,75	127	95	38	13	16	14	64	31	12,7	M10	12160	6318	UC202 UC202-9 UC202-10	LP204	0,69
UCLP202-9	5/8	1 1/4	5	3 3/4	1 1/2	1/2	5/8	9/16	2 3/4	1,2205	0,500	3/8					0,69
UCLP203	17	31,75	127	95	38	13	16	14	64	31	12,7	M10	12160	6318	UC203 UC203-11	LP204	0,68
UCP203-11	1 1/16	1 1/4	5	3 3/4	1 1/2	1/2	5/8	9/16	2 3/4	1,2205	0,500	3/8					0,67
UCLP204	20	31,75	127	95	38	13	16	14	64	31	12,7	M10	12160	6318	UC204 UC204-12	LP204	0,66
UCP204-12	3/4	1 1/4	5	3 3/4	1 1/2	1/2	5/8	9/16	2 3/4	1,2205	0,500	3/8					0,66
UCLP205	25	33,34	140	105	38	13	16	15	68	34,1	14,3	M10	13300	7457	UC205 UC205-13 UC205-14 UC205-15 UC205-16	LP205	0,81
UCLP205-13	1 9/16																0,85
UCLP205-14	7/8																0,83
UCLP205-15	1 1/16	1 3/16	5 1/2	4 1/8	1 1/2	1/2	5/8	1 1/32	2 43/64	1,3425	0,563	3/8					0,82
UCLP205-16	1																0,81
UCLP206	30	39,69	165	121	48	17	20	17	80	38,1	15,9	M14	18525	10735	UC206 UC206-17 UC206-18 UC206-19 UC206-20	LP206	1,24
UCLP206-17	1 1/16																1,27
UCLP206-18	1 1/8	1 9/16	6 1/2	4 3/4	1 7/8	4 3/64	2 5/32	2 1/32	3 5/32	1,5000	0,626	1/2					1,26
UCLP206-19	1 3/16																1,24
UCLP206-20	1 1/4																1,23
UCLP207	35	46,04	167	127	48	17	20	18	91	42,9	17,5	M14	24415	14630	UC207 UC207-20 UC207-21 UC207-22 UC207-23	LP207	1,58
UCLP207-20	1 1/4																1,64
UCLP207-21	1 3/16	1 13/16	6 9/16	5	1 7/8	4 3/64	2 5/32	4 5/64	3 37/64	1,6890	0,689	1/2					1,61
UCLP207-22	1 3/8																1,58
UCLP207-23	1 7/16																1,55
UCLP208	40	49,2	184	137	54	17	20	18	100	49,2	19	M14	27645	16910	UC208 UC208-24 UC208-25	LP208	1,89
UCLP208-24	1 1/2	1 15/16	7 1/4	5 13/32	2 1/8	4 3/64	2 5/32	4 5/64	3 15/16	1,9370	0,748	1/2					1,93
UCLP208-25	1 3/16																1,90
UCLP209	45	52,39	190	146	54	17	20	20	104	49,2	19	M14	32395	20235	UC209 UC209-26 UC209-27 UC209-28	LP209	2,14
UCLP209-26	1 5/8																2,24
UCLP209-27	1 11/16	2 1/16	7 15/32	5 3/4	2 1/8	4 3/64	2 5/32	2 5/32	4 3/32	1,9370	0,748	1/2					2,20
UCLP209-28	1 3/4																2,14
UCLP210	50	55,56	206	159	60	20	23	21	112	51,6	19	M16	33345	22135	UC210 UC210-29 UC210-30 UC210-31 UC210-32	LP210	2,66
UCLP210-29	1 13/16																2,78
UCLP210-30	1 7/8	2 3/16	8 1/8	6 1/4	2 3/8	2 5/32	2 9/32	5 3/64	4 13/32	2,0315	0,748	5/8					2,73
UCLP210-31	1 15/16																2,68
UCLP210-32	2																2,64
UCLP211	55	61,91	219	171	60	20	23	23	124	55,6	22,2	M16	41230	27930	UC211 UC211-32 UC211-33 UC211-34 UC211-35	LP211	3,31
UCLP211-32	2																3,46
UCLP211-33	2 1/16	2 7/16	8 5/8	6 47/64	2 3/8	2 5/32	2 9/32	2 9/32	4 7/8	2,1890	0,874	5/8					3,40
UCLP211-34	2 1/8																3,35
UCLP211-35	2 3/16																3,29
UCLP212	60	68,26	241	184	70	20	23	25	136	65,1	25,4	M16	49780	34390	UC212 UC212-36 UC212-37 UC212-38 UC212-39	LP212	4,90
UCLP212-36	2 1/4																5,03
UCLP212-37	2 5/16	2 11/16	9 1/2	7 1/4	2 3/4	2 5/32	2 9/32	6 3/64	5 23/64	2,5630	1,000	5/8					4,95
UCLP212-38	2 3/8																4,88
UCLP212-39	2 7/16																4,81

UCP3 Serie pesante - Heavy duty

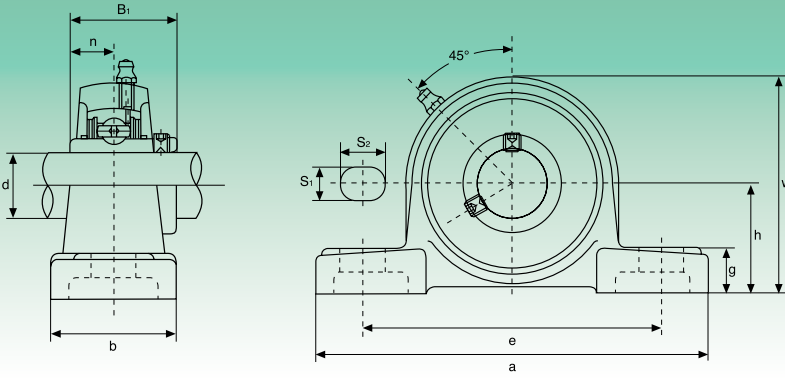

Tipo Type	Dimensioni - Dimensions											Bull. fiss. Bolt Size	Coefficienti di carico (N) Load ratings (N)		Cuscinetto Bearing	Supporto Housing	Peso Weight											
	d	h	a	e	b	S ₁	S ₂	g	w	B ₁	n		Dinamico C Dynamic C	Statico C ₀ Static C ₀				kg										
	mm/inch												mm/inch															
UCP305 UCP305-13 UCP305-14 UCP305-15 UCP305-16	25 1 1/4	45	175	132	45	17	20	15	85	38	15	M14	20140	10355	UC305 UC305-13 UC305-14 UC305-15 UC305-16	P305	1,4											
UCP306 UCP306-17 UCP306-18 UCP306-19	30 1 1/4	50	180	140	50	17	20	18	95	43	17	M14						25365	14250	UC306 UC306-17 UC306-18 UC306-19	P306	1,8						
UCP307 UCP307-20 UCP307-21 UCP307-22 UCP307-23	35 1 1/4	56	210	160	56	17	25	20	106	48	19	M14						31730	18335				UC307 UC307-20 UC307-21 UC307-22 UC307-23	P307	2,8			
UCP308 UCP308-24 UCP308-25	40 1 1/2	60	220	170	60	17	27	22	116	52	19	M14						38665	22800							UC308 UC308-24 UC308-25	P308	3,0
UCP309 UCP309-26 UCP309-27 UCP309-28	45 1 3/4	67	245	190	67	20	30	24	129	57	22	M16						46455	28025									
UCP310 UCP310-29 UCP310-30 UCP310-31	50 1 3/4	75	275	212	75	20	35	27	143	61	22	M16	58900	36385	UC310 UC310-29 UC310-30 UC310-31	P310	5,8											
UCP311 UCP311-32 UCP311-33 UCP311-34 UCP311-35	55 2	80	310	236	80	20	38	30	154	66	25	M16	68020	42750				UC311 UC311-32 UC311-33 UC311-34 UC311-35	P311	7,4								
UCP312 UCP312-36 UCP312-37 UCP312-38 UCP312-39	60 2 1/4	85	330	250	85	25	38	32	165	71	26	M20	77805	49590							UC312 UC312-36 UC312-37 UC312-38 UC312-39	P312	9,4					
UCP313 UCP313-40 UCP313-41	65 2 1/2	90	340	260	90	25	38	33	176	75	30	M20	88065	56905	UC313 UC313-40 UC313-41	P313	10											
UCP314 UCP314-42 UCP314-43 UCP314-44	70 2 3/4	95	360	280	90	27	40	35	187	78	33	M22	98800	64790										UC314 UC314-42 UC314-43 UC314-44	P314	12		
UCP315 UCP315-45 UCP315-46 UCP315-47 UCP315-48	75 2 3/4	100	380	290	100	27	40	35	198	82	32	M22	107350	73340	UC315 UC315-45 UC315-46 UC315-47 UC315-48	P315	14											
UCP316 UCP316-49 UCP316-50 UCP316-51	80 3 1/4	106	400	300	110	27	40	40	210	86	34	M22	111850	82365				UC316 UC316-49 UC316-50 UC316-51	P316	18								
UCP317 UCP317-52 UCP317-53 UCP317-55	85 3 3/4	112	420	320	110	33	45	40	220	96	40	M27	126350	91960							UC317 UC317-52 UC317-53 UC317-55	P317	20					
UCP318 UCP318-55 UCP318-56	90 3 3/4	118	430	330	110	33	45	45	235	96	40	M27	135850	101650										UC318 UC318-55 UC318-56	P318	24		
UCP319 UCP319-58 UCP319-59 UCP319-60	95 3 3/4	125	470	360	120	36	50	45	250	103	41	M30	145350	113050	UC319 UC319-58 UC319-59 UC319-60	P319	29											
UCP320 UCP320-64	100 4	140	490	380	120	36	50	50	275	108	42	M30	164350	133950				UC320 UC320-64	P320	35								
UCP321	105	140	490	380	120	36	50	56	283	112	44	M33	174800	145350							UC321	P321	35					
UCP322	110	150	520	400	140	40	55	61	303	117	46	M33	194750	171000				UC322	P322	45								
UCP324	120	160	570	450	140	40	55	71	323	126	51	M33	196650	175750	UC324	P324	55											
UCP326	130	180	600	480	140	40	55	81	363	135	54	M33	217550	203300	UC326	P326	72											
UCP328	140	200	620	500	140	40	55	81	403	145	59	M33	240350	233700	UC328	P328	89											

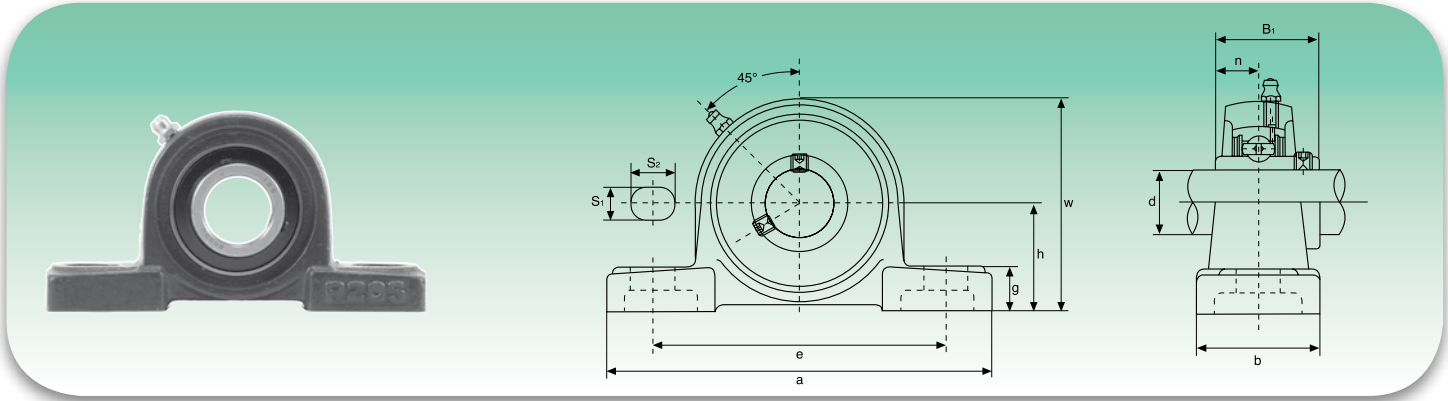

Tipo Type	Dimensioni - Dimensions											Bull. fiss. Bolt Size	Coefficienti di carico (N) Load ratings (N)		Cuscinetto Bearing	Supporto Housing	Peso Weight
	d	h	a	e	b	S ₁	S ₂	g	w	B ₁	n		Dinamico C Dynamic C	Statico C ₀ Static C ₀			
	mm/inch												mm/inch				
UCPX05 UCPX05-13 UCPX05-14 UCPX05-15 UCPX05-16	25 1 13/16 7/8 1 15/16 1	44,4 1 3/4	159 6 1/4	119 4 11/16	51 2	17 4 3/64	20 2 5/32	18 2 9/32	85 3 11/32	38,1 1,5000	15,9 0,626	M14 1/2	18525	10735	UCX05 UCX05-13 UCX05-14 UCX05-15 UCX05-16	PX05	1,5
UCPX06 UCPX06-17 UCPX06-18 UCPX06-19 UCPX06-20	30 1 1/16 1 1/8 1 3/16 1 1/4	47,6 1 7/8	175 6 7/8	127 5	57 2 1/4	17 4 3/64	20 2 5/32	20 2 5/32	93 3 31/32	42,9 1,6890	17,5 0,689	M14 1/2	24415	14630	UCX06 UCX06-17 UCX06-18 UCX06-19 UCX06-20	PX06	2,0
UCPX07 UCPX07-21 UCPX07-22 UCPX07-23	35 1 3/16 1 3/8 1 7/16	54,0 2 1/8	203 8	144 5 1/2	57 2 1/4	17 4 3/64	20 2 5/32	21 1 3/16	105 4 1/8	49,2 1,9370	19 0,748	M14 1/2	27645	16910	UCX07 UCX07-21 UCX07-22 UCX07-23	PX07	2,6
UCPX08 UCPX08-24 UCPX08-25	40 1 1/2 1 9/16	58,7 2 5/16	222 8 3/4	156 6 5/32	67 2 5/8	20 2 5/32	23 2 9/32	26 1 1/32	111 4 3/8	49,2 1,9370	19 0,748	M16 5/8	32395	20235	UCX08 UCX08-24 UCX08-25	PX08	3,3
UCPX09 UCPX09-26 UCPX09-27 UCPX09-28 UCPX09-29	45 1 5/8 1 11/16 1 3/4 1 13/16	58,7 2 5/16	222 8 3/4	156 6 5/32	67 2 5/8	20 2 5/32	23 2 9/32	26 1 1/32	116 4 9/16	51,6 2,0315	19 0,748	M16 5/8	33345	22135	UCX09 UCX09-26 UCX09-27 UCX09-28 UCX09-29	PX09	3,3
UCPX10 UCPX10-30 UCPX10-31 UCPX10-32	50 1 7/8 1 15/16 2	63,5 2 1/2	241 9 1/2	171 6 47/64	73 2 7/8	20 2 5/32	23 2 9/32	27 1 1/16	126 4 31/32	55,6 2,1890	22,2 0,874	M16 5/8	41230	27930	UCX10 UCX10-30 UCX10-31 UCX10-32	PX10	4,3
UCPX11 UCPX11-33 UCPX11-34 UCPX11-35 UCPX11-36 UCPX11-37	55 2 1/16 2 1/8 2 3/16 2 1/4 2 5/16	69,8 2 3/4	260 10 1/4	184 7 1/4	79 3 3/8	25 3 1/32	28 1 3/32	30 1 3/16	137 5 13/32	65,1 2,5630	25,4 1,000	M20 3/4	49780	34390	UCX11 UCX11-33 UCX11-34 UCX11-35 UCX11-36 UCX11-37	PX11	5,7
UCPX12 UCPX12-38 UCPX12-39	60 2 3/8 2 7/16	76,2 3	286 11 1/4	203 8	83 3 3/32	25 3 1/32	28 1 3/32	33 1 1/16	151 5 11/16	65,1 2,5630	25,4 1,000	M20 3/4	54340	38095	UCX12 UCX12-38 UCX12-39	PX12	7,3
UCPX13 UCPX13-40 UCPX13-41	65 2 1/2 2 9/16	76,2 3	286 11 1/4	203 8	83 3 3/32	25 6 3/64	28 1 3/32	33 1 1/16	154 6 1/16	74,6 2,9370	30,2 1,189	M20 3/4	59090	41895	UCX13 UCX13-40 UCX13-41	PX13	7,6
UCPX14 UCPX14-42 UCPX14-43 UCPX14-44	70 2 5/8 2 11/16 2 3/4	88,9 3 1/2	330 13	229 9 1/32	89 3 1/2	27 1 1/16	30 1 3/16	35 1 3/8	170 6 1/16	77,8 3,0630	33,3 1,311	M22 7/8	64030	45885	UCX14 UCX14-42 UCX14-43 UCX14-44	PX14	9,9
UCPX15 UCPX15-45 UCPX15-46 UCPX15-47 UCPX15-48	75 2 13/16 2 7/8 2 15/16 3	88,9 3 1/2	330 13	229 9 1/32	89 3 1/2	27 1 1/16	30 1 3/16	35 1 3/8	175 6 7/8	82,6 3,2520	33,3 1,311	M22 7/8	69065	50350	UCX15 UCX15-45 UCX15-46 UCX15-47 UCX15-48	PX15	11
UCPX16 UCPX16-49 UCPX16-50 UCPX16-51 UCPX16-52	80 3 1/16 3 3/8 3 3/16 3 3/4	101,6 4	381 15	283 11 1/32	102 4 1/2	27 1 1/16	30 1 3/16	40 1 1/16	194 7 7/8	85,7 3,3740	34,1 1,343	M22 7/8	79800	58805	UCX16 UCX16-49 UCX16-50 UCX16-51 UCX16-52	PX16	15
UCPX17 UCPX17-53 UCPX17-55	85 3 3/16 3 7/16	101,6 4	381 15	283 11 1/32	102 4 1/2	27 1 1/16	30 1 3/16	40 1 1/16	200 7 7/8	96 3,7795	39,7 1,563	M22 7/8	91295	67925	UCX17 UCX17-53 UCX17-55	PX17	16
UCPX18 UCPX18-56 UCPX18-57	90 3 7/16 3 1/2	101,6 4	381 15	283 11 1/32	111 4 3/8	27 1 1/16	30 1 3/16	40 1 1/16	206 8 1/8	104 4,0945	42,9 1,689	M22 7/8	103550	77805	UCX18 UCX18-56 UCX18-57	PX18	17
UCPX20 UCPX20-58 UCPX20-59 UCPX20-60 UCPX20-61	100 3 13/16 3 7/8 3 15/16 4	127 5	432 17	337 13 3/32	121 4 3/4	33 1 1/16	36 1 13/32	45 1 25/32	244 9 19/32	117,5 4,6260	49,2 1,937	M27 1	126350	99750	UCX20 UCX20-58 UCX20-59 UCX20-60 UCX20-61	PX20	30

UKP2 Serie normale - Standard duty

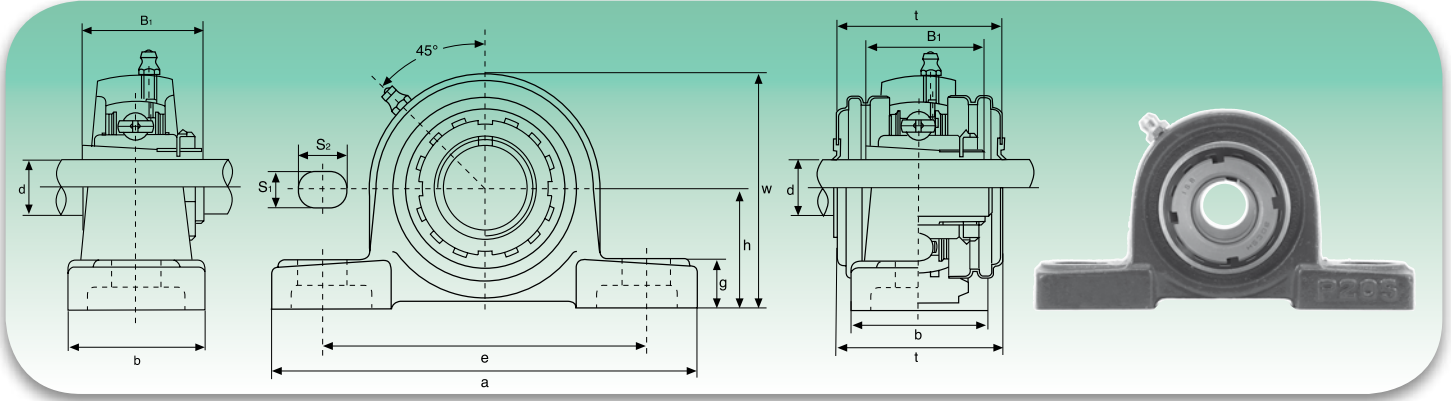

Tipo Type	Dimensioni - Dimensions											Bull. fiss. Bolt Size	Coefficienti di carico (N) Load ratings (N)		Cuscinetto Bearing	Supporto Housing	Peso Weight	
	d	h	a	e	b	S ₁	S ₂	g	w	t	B ₁		Dinamico C Dynamic C	Statico C ₀ Static C ₀				kg
	mm/inch												mm/inch					
UKP205+H2305	20	36,5	140	105	38	13	19	15	71	48	35	M10	13300	7457	UK205+H2305	P205	0,86	
UKP205+HE2305	¾	1 1/16	5 1/2	4 1/8	1 1/2	1/2	¾	1 9/32	2 25/32	1 57/64	1,378	¾			UK205+HE2305			
UKP206+H2306	25	42,9	165	121	48	17	20	17	84	53	38	M14	18525	10735	UK206+H2306	P206	1,28	
UKP206+HS2306	7/8	1 11/16	6 1/2	4 3/4	1 7/8	4 3/64	2 5/32	4 3/64	3 3/16	2 5/64	1,496	1/2			UK206+HS2306			
UKP206+HE2306	1	1 11/16	6 1/2	4 3/4	1 7/8	4 3/64	2 5/32	4 3/64	3 3/16	2 5/64	1,496	1/2			UK206+HE2306			
UKP207+H2307	30	47,6	167	127	48	17	20	18	93	59,5	43	M14	24415	14630	UK207+H2307	P207	1,67	
UKP207+HS2307	1 1/8	1 7/8	6 5/16	5	1 7/8	4 3/64	2 5/32	4 5/64	3 21/32	2 11/32	1,693	1/2			UK207+HS2307			
UKP208+H2308	35	49,2	184	137	54	17	20	18	100	69	46	M14	27645	16910	UK208+H2308	P208	1,99	
UKP208+HE2308	1 1/4	1 15/16	7 1/4	5 1 3/32	2 1/8	4 3/64	2 5/32	4 5/64	3 1 5/16	2 23/32	1,811	1/2			UK208+HE2308			
UKP208+HS2308	1 3/8	1 15/16	7 1/4	5 1 3/32	2 1/8	4 3/64	2 5/32	4 5/64	3 1 5/16	2 23/32	1,811	1/2			UK208+HS2308			
UKP209+H2309	40	54	190	146	54	17	20	20	106	69	50	M14	32395	20235	UK209+H2309	P209	1,29	
UKP209+HA2309	1 7/16														UK209+HA2309			
UKP209+HE2309	1 1/2	2 1/8	7 1 5/32	5 3/4	2 1/8	4 3/64	2 5/32	2 5/32	4 1 5/64	2 23/32	1,969	1/2			UK209+HE2309			
UKP209+HS2309	1 5/8														UK209+HS2309			
UKP210+H2310	45	57,2	206	159	60	20	23	21	113	74,5	55	M16	33345	22135	UK210+H2310	P210	2,83	
UKP210+HS2310	1 5/8														UK210+HS2310			
UKP210+HA2310	1 11/16	2 1/4	8 1/8	6 1/4	2 3/8	2 5/32	2 9/32	5 3/64	4 2 5/64	2 1 5/16	2,165	5/8			UK210+HA2310			
UKP210+HE2310	1 3/4														UK210+HE2310			
UKP211+H2311	50	63,5	219	171	60	20	23	23	125	76	59	M16	41230	27930	UK211+H2311	P211	3,46	
UKP211+HS2311	1 7/8														UK211+HS2311			
UKP211+HA2311	1 15/16	2 1/2	8 5/8	6 4 7/64	2 3/8	2 5/32	2 9/32	2 9/32	4 5 9/64	3	2,323	5/8			UK211+HA2311			
UKP211+HE2311	2														UK211+HE2311			
UKP212+H2312	55	69,8	241	184	70	20	23	25	138	89	62	M16	49780	34390	UK212+H2312	P212	4,95	
UKP212+HS2312	2 1/8	2 3/4	9 1/2	7 1/4	2 3/4	2 5/32	2 9/32	6 3/64	5 7/16	3 1/2	2,441	5/8			UK212+HS2312			
UKP213+H2313	60	76,2	265	203	70	25	28	27	150	89	65	M20	54340	38095	UK213+H2313	P213	5,06	
UKP213+HA2313	2 3/16														UK213+HA2313			
UKP213+HE2313	2 1/4	3	10 1/16	8	2 3/4	6 3/64	1 3/32	1 1/16	5 2 9/32	3 1/2	2,559	3/4			UK213+HE2313			
UKP213+HS2313	2 3/8														UK213+HS2313			
UKP215+H2315	65	82,6	275	217	74	25	28	28	162	-	73	M20	64030	45885	UK215+H2315	P215	7,27	
UKP215+HA2315	2 7/16														UK215+HA2315			
UKP215+HE2315	2 1/2	3 1/4	10 5 3/64	8 3 5/64	2 2 9/32	6 3/64	1 3/32	1 3/32	6 3/8	-	2,874	3/4			UK215+HE2315			
UKP216+H2316	70	88,9	292	232	78	25	28	30	174	-	78	M20	69065	50350	UK216+H2316	P216	8,36	
UKP216+HA2316	2 11/16														UK216+HA2316			
UKP216+HE2316	2 3/4	3 1/2	11 1/2	9 1/8	3 1/16	6 3/64	1 3/32	1 3/16	6 2 7/32	-	3,071	3/4			UK216+HE2316			
UKP217+H2317	75	95,2	310	247	83	25	28	32	185	-	82	M20	79800	58805	UK217+H2317	P217	10,23	
UKP217+HA2317	2 15/16														UK217+HA2317			
UKP217+HE2317	3	3 3/4	12 1 3/64	9 2 3/32	3 1 7/64	6 3/64	1 3/32	1 1/4	7 7/32	-	3,228	3/4			UK217+HE2317			
UKP218+H2318	80	101,6	327	262	88	27	30	33	198	-	86	M22	91295	67925	UK218+H2318	P218	12,34	
UKP218+HA2318	3 3/16	4	12 7/8	10 1/16	3 1 5/32	1 1/16	1 3/16	1 1 9/64	7 5/64	-	3,386	7/8			UK218+HA2318			

Bussole HA; HE; HS con filettatura in pollici
Inch dimension adapter sleeves HA; HE; HS

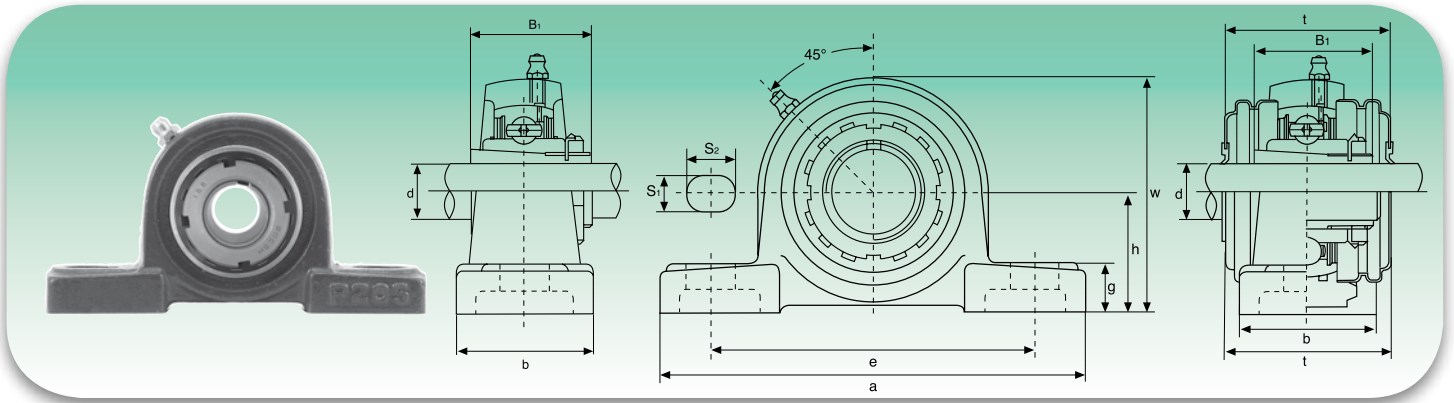

Tipo Type	Dimensioni - Dimensions										Bull. fiss. Bolt Size	Coefficienti di carico (N) Load ratings (N)		Cuscinetto Bearing	Supporto Housing	Peso Weight	
	d	h	a	e	b	S ₁	S ₂	g	w	B ₁		Dinamico C Dynamic C	Statico C ₀ Static C ₀				kg
	mm/inch											mm/inch					
UKP305+H2305 UCP305+HE2305	20 ¾	45 1 49/64	175 6 7/8	132 5 1/16	45 1 3/4	17 43/64	20 1 9/32	15 25/32	85 3 11/32	35 1,378	M14 ½	20140	10355	UK305+H2305 UK305+HE2305	P305	1,7	
UKP306+H2306 UKP306+HS2306 UKP306+HE2306	25 7/8 1	50 1 31/32	180 7 3/32	140 5 1/2	50 1 31/32	17 43/64	20 25/32	18 23/32	95 3 3/4	38 1,496	M14 ½	25365	14250	UK306+H2306 UK306+HS2306 UK306+HE2306	P306	2,3	
UKP307+H2307 UKP307+HS2307	30 1 1/8	56 2 13/64	210 8 9/32	160 6 1/16	56 2 1/32	17 43/64	25 9/64	20 25/32	106 4 1/16	43 1,693	M14 ½	31730	18335	UK307+H2307 UK307+HS2307	P307	3,0	
UKP308+H2308 UKP308+HE2308 UKP308+HS2308	35 1 1/4 1 3/8	60 2 23/64	220 8 21/32	170 6 1/16	60 2 3/8	17 43/64	27 1 1/16	22 7/8	116 4 4/16	46 1,811	M16 5/8	38665	22800	UK308+H2308 UK308+HE2308 UK308+HS2308	P308	3,8	
UKP309+H2309 UKP309+HA2309 UKP309+HE2309 UKP309+HS2309	40 1 7/16 1 1/2 1 5/8	67 1 41/64	245 9 21/32	190 7 1/2	67 2 5/8	20 25/32	30 1 3/16	24 1 5/16	129 5 3/32	50 1,969	M16 5/8	46455	28025	UK309+H2309 UK309+HA2309 UK309+HE2309 UK309+HS2309	P309	5,0	
UKP310+H2310 UKP310+HS2310 UKP310+HA2310 UKP310+HE2310	45 1 5/8 1 11/16 1 3/4	75 2 61/64	275 10 13/16	212 8 11/32	75 2 5/16	20 25/32	35 1 3/8	27 1 1/16	143 5 5/8	55 2,165	M16 5/8	58900	36385	UK310+H2310 UK310+HS2310 UK310+HA2310 UK310+HE2310	P310	6,7	
UKP311+H2311 UKP311+HS2311 UKP311+HA2311 UKP311+HE2311	50 1 7/8 1 15/16 2	80 3 3/32	310 12 2/32	236 9 9/32	80 3 3/32	20 25/32	38 1 1/2	30 1 3/16	154 6 1/16	59 2,323	M16 5/8	68020	42750	UK311+H2311 UK311+HS2311 UK311+HA2311 UK311+HE2311	P311	8,1	
UKP312+H2312 UKP312+HS2312	55 2 1/8	85 3 11/32	330 12	250 9 27/32	85 3 11/32	25 63/64	38 1 1/2	32 1 1/4	165 6 1/2	62 2,441	M20 3/4	77805	49590	UK312+H2312 UK312+HS2312	P312	9,4	
UKP313+H2313 UKP313+HA2313 UKP313+HE2313 UKP313+HS2313	60 2 3/16 2 1/4 2 3/8	90 3 33/64	340 13 3/8	260 10 1/4	90 3 17/32	25 63/64	38 1 1/2	33 1 1/16	176 6 5/16	65 2,559	M20 3/4	88065	56905	UK313+H2313 UK313+HA2313 UK313+HE2313 UK313+HS2313	P313	10,8	
UKP315+H2315 UKP315+HA2315 UKP315+HE2315	65 2 7/16 2 1/2	100 3 5/16	380 14 31/32	290 11 13/32	100 3 5/16	27 1 1/16	40 1 3/8	35 1 3/8	198 7 25/32	73 2,874	M22 7/8	107350	73340	UK315+H2315 UK315+HA2315 UK315+HE2315	P315	14,9	
UKP316+H2316 UKP316+HA2316 UKP316+HE2316	70 2 11/16 2 3/4	106 4 1/16	400 15 3/4	300 11 13/16	110 4 11/32	27 1 1/16	40 1 3/16	40 1 1/16	210 8 9/32	78 3,071	M22 7/8	116850	82365	UK316+H2316 UK316+HA2316 UK316+HE2316	P316	18,6	
UKP317+H2317 UKP317+HA2317 UKP317+HS2317	75 2 15/16 3	112 4 1/16	420 16 17/32	320 12 19/32	110 4 11/32	33 1 1/16	45 1 25/32	40 1 1/16	220 8 21/32	82 3,228	M27 1	126350	91960	UK317+H2317 UK317+HA2317 UK317+HS2317	P317	20,2	
UKP318+H2318 UKP318+HA2318	80 3 3/16	118 4 41/64	430 16 15/16	330 13	110 4 11/32	33 1 1/16	45 1 25/32	45 1 25/32	235 9 1/4	86 3,386	M27 1	135850	101650	UK318+H2318 UK318+HA2318	P318	22,8	
UKP319+H2319 UKP319+HA2319	85 3 5/16	125 4 59/64	470 18 1/2	360 14 3/16	120 4 23/32	36 1 13/32	50 1 31/32	45 1 25/32	250 9 27/32	90 3,543	M30 1 1/8	145350	113050	UK319+H2319 UK319+HA2319	P319	29,3	
UKP320+H2320 UKP320+HA2320	90 3 1/8	140 5 33/64	490 19 9/32	380 14 31/32	120 4 23/32	36 1 13/32	50 1 31/32	50 1 31/32	275 10 53/64	97 3,814	M30 1 1/8	164350	133950	UK320+H2320 UK320+HA2320	P320	34,8	
UKP322+H2322 UKP322+HA2322	100 3 5/16	150 5 29/32	520 20 15/32	400 15 3/4	140 5 1/2	40 1 1/16	55 2 5/32	55 2 5/32	300 11 13/16	105 4,134	M33 1 1/4	194750	171000	UK322+H2322 UK322+HA2322	P322	43,9	
UKP324+H2324 UKP324+HA2324	110 4 3/16	160 6 19/64	570 22 7/16	450 17 23/32	140 5 1/2	40 1 1/16	55 2 5/32	65 1 21/32	320 12 9/32	112 4,410	M33 1 1/4	196650	175750	UK324+H2324 UK324+HA2324	P324	55,7	
UKP326+H2326 UKP326+HA2326	115 4 7/16	180 7 3/32	600 23 5/8	480 18 29/32	140 5 1/2	40 1 1/16	55 2 5/32	75 2 9/64	335 13 31/32	121 4,764	M33 1 1/4	217550	203300	UK326+H2326 UK326+HA2326	P326	71,9	
UKP328+H2328 UKP328+HA2328	125 4 15/16	200 7 7/8	620 24 13/32	500 19 11/16	140 5 1/2	40 1 1/16	55 2 5/32	75 2 9/64	390 15 33/64	131 5,158	M33 1 1/4	240350	233700	UK328+H2328 UK328+HA2328	P328	92,5	

Bussolle HA; HE; HS con filettatura in pollici
Inch dimension adapter sleeves HA; HE; HS

UKPX Serie media - Medium duty

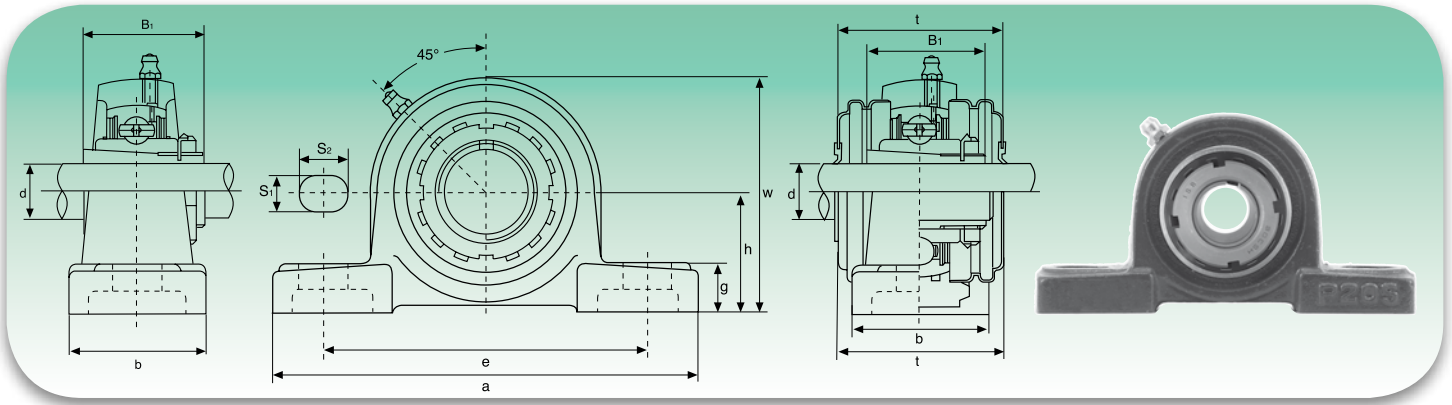

Tipo Type	Dimensioni - Dimensions										Bull. fiss. Bolt Size	Coefficients di carico (N) Load ratings (N)		Cuscinetto Bearing	Supporto Housing	Peso Weight	
	d	h	a	e	b	S ₁	S ₂	g	w	B ₁		Dinamico C Dynamic C	Statico C ₀ Static C ₀				kg
	mm/inch											mm/inch					
UKPX05+H2305	20	44,4	159	119	51	17	20	18	85	35	M14	18525	10735	UKX05+H2305	PX05	1,5	
UKPX05+HE2305	¾	1¾	6¼	4 ¹¹ / ₁₆	2	4 ³ / ₆₄	2 ⁵ / ₃₂	3 ¹¹ / ₃₂	1,378	½	½			UKX05+HE2305			
UKPX06+H2306	25	47,6	175	127	57	17	20	20	93	38	M14	24415	14630	UKX06+H2306	PX06	2,1	
UKPX06+HS2306	7/8	1 7/8	6 7/8	5	2 1/4	4 3/64	2 5/32	2 5/32	3 2 1/2	1,496	½			UKX06+HS2306			
UKPX06+HE2306	1													UKX06+HE2306			
UKPX07+H2307	30	54,0	203	144	57	17	20	21	105	43	M14	27645	16910	UKX07+H2307	PX07	2,7	
UKPX07+HS2307	1 1/8	2 1/8	8	5 2 1/2	2 1/4	4 3/64	2 5/32	1 3/16	4 1/8	1,693	½			UKX07+HS2307			
UKPX08+H2308	35	58,7	222	156	67	20	23	26	111	46	M16	32395	20235	UKX08+H2308	PX08	3,5	
UKPX08+HE2308	1 1/4	2 5/16	8 3/4	6 3/32	2 5/8	2 5/32	2 9/32	1 1/32	4 3/8	1,811	5/8			UKX08+HE2308			
UKPX08+HS2308	1 3/8													UKX08+HS2308			
UKPX09+H2309	40	58,7	222	156	67	20	23	26	116	50	M16	33345	22135	UKX09+H2309	PX09	3,7	
UKPX09+HA2309	1 1/16													UKX09+HA2309			
UKPX09+HE2309	1 1/2	2 5/16	8 3/4	6 5/32	2 5/8	2 5/32	2 9/32	1 1/32	4 7/8	1,969	5/8	UKX09+HE2309					
UKPX09+HS2309	1 5/8													UKX09+HS2309			
UKPX10+H2310	45	63,5	241	171	73	20	23	27	126	55	M16	41230	27930	UKX10+H2310	PX10	4,6	
UKPX10+HS2310	1 5/8													UKX10+HS2310			
UKPX10+HA2310	1 11/16	2 1/2	9 1/2	6 4 7/64	2 7/8	2 5/32	2 9/32	1 1/16	4 3 1/2	2,165	5/8	UKX10+HA2310					
UKPX10+HE2310	1 3/4													UKX10+HE2310			
UKPX11+H2311	50	69,8	260	184	79	25	28	30	137	59	M20	49780	34390	UKX11+H2311	PX11	6,2	
UKPX11+HS2311	1 7/8													UKX11+HS2311			
UKPX11+HA2311	1 15/16	2 3/4	10 1/4	7 1/4	3 1/8	3 1/32	1 3/32	1 3/16	5 1 3/32	2,323	3/4	UKX11+HA2311					
UKPX11+HE2311	2													UKX11+HE2311			
UKPX12+H2312	55	76,2	286	203	83	25	28	33	151	62	M20	54340	38095	UKX12+H2312	PX12	7,5	
UKPX12+HS2312	2 1/8	3	11 1/4	8	3 3/32	6 3/64	1 3/32	1 5/16	2,441	3/4	3/4			UKX12+HS2312			
UKPX13+H2313	60	76,2	286	203	83	25	28	33	154	65	M20	59090	41895	UKX13+H2313	PX13	7,8	
UKPX13+HA2313	2 3/16													UKX13+HA2313			
UKPX13+HE2313	2 1/4	3	11 1/4	8	3 3/32	6 3/64	1 3/32	1 5/16	6 1/16	2,559	3/4	UKX13+HE2313					
UKPX13+HS2313	2 3/8													UKX13+HS2313			
UKPX15+H2315	65	88,9	330	229	89	27	30	35	175	73	M22	69065	50350	UKX15+H2315	PX15	10,5	
UKPX15+HA2315	2 5/16													UKX15+HA2315			
UKPX15+HE2315	2 1/2	3 1/2	13	9 5/32	3 1/2	1 1/16	1 3/16	1 3/8	6 7/8	2,874	7/8	UKX15+HE2315					
UKPX16+H2316	70	101,6	381	283	102	27	30	40	194	78	M22	79800	58805	UKX16+H2316	PX16	15,4	
UKPX16+HA2316	2 11/16													UKX16+HA2316			
UKPX16+HE2316	2 3/4	4	15	11 5/32	4 1/32	1 1/16	1 3/16	1 1/16	7 5/8	3,071	7/8	UKX16+HE2316					
UKPX17+H2317	75	101,6	381	283	102	27	30	40	200	82	M22	91295	67925	UKX17+H2317	PX17	15,8	
UKPX17+HA2317	2 15/16													UKX17+HA2317			
UKPX17+HE2317	3	4	15	11 5/32	4 1/32	1 1/16	1 3/16	1 1/16	7 7/8	3,228	7/8	UKX17+HE2317					
UKPX18+H2318	80	101,6	381	283	111	27	30	40	206	86	M22	103550	77805	UKX18+H2318	PX18	18,6	
UKPX18+HA2318	3 3/16													UKX18+HA2318			
UKPX18+HE2318	3 1/2	4	15	11 5/32	4 3/8	1 1/16	1 3/16	1 1/16	8 1/8	3,386	7/8	UKX18+HE2318					
UKPX20+H2320	90	127	432	337	121	33	36	45	244	97	M27	126350	99750	UKX20+H2320	PX20	29,3	
UKPX20+HA2320	3 1/2	5	17	13 9/32	4 3/4	1 1/16	1 1 1/32	1 2 5/32	9 5/8	3,814	1 1/16			UKX20+HA2320			

Bussole HA; HE; HS con filettatura in pollici
Inch dimension adapter sleeves HA; HE; HS

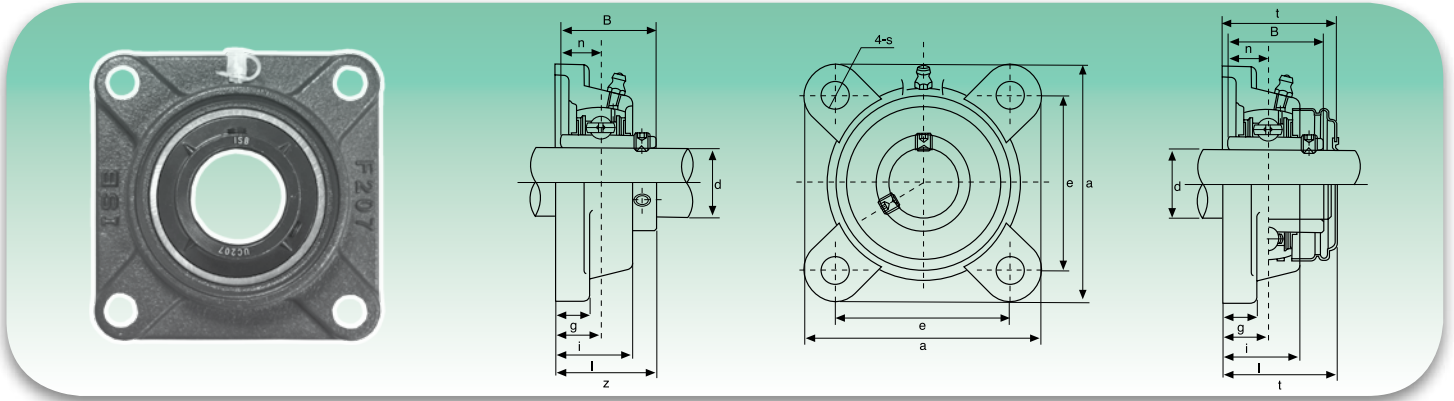

Tipo Type	Dimensioni - Dimensions											Bull. fess. Bolt Size	Coefficients di carico (N) Load ratings (N)		Cuscinetto Bearing	Supporto Housing	Peso Weight	
	d	a	e	i	g	l	s	z	t	B	n		Dinamico C Dynamic C	Statico C ₀ Static C ₀				kg
	mm/inch												mm/inch					
UCF201	12	86	64	15	12	25,5	12	33,3	37,5	31	12,7	M10	12160	6318	UC201	F204	0,60	
UCF201-8	3/4	3 3/8	2 3/4	1 1/2	1 1/2	1	1 1/2	1 1/4	1 3/4	1,2205	0,500	3/8			UC201-8		0,59	
UCF202	15	86	64	15	12	25,5	12	33,3	37,5	31	12,7	M10	12160	6318	UC202	F204	0,59	
UCF202-9	9/16	3 3/8	2 3/4	1 1/2	1 1/2	1	1 1/2	1 1/4	1 3/4	1,2205	0,500	3/8			UC202-9		0,59	
UCF202-10	5/8														UC202-10		0,59	
UCF203	17	86	64	15	12	25,5	12	33,3	37,5	31	12,7	M10	12160	6318	UC203	F204	0,58	
UCF203-11	1 1/16	3 3/8	2 3/4	1 1/2	1 1/2	1	1 1/2	1 1/4	1 3/4	1,2205	0,500	3/8			UC203-11		0,57	
UCF204	20	86	64	15	12	25,5	12	33,3	37,5	31	12,7	M10	12160	6318	UC204	F204	0,56	
UCF204-12	3/4	3 3/8	2 3/4	1 1/2	1 1/2	1	1 1/2	1 1/4	1 3/4	1,2205	0,500	3/8			UC204-12		0,56	
UCF205	25	95	70	16	14	27	12	35,8	40	34,1	14,3	M10			UC205	F205	0,80	
UCF205-13	1 3/16												13300	7457	UC205-13		0,84	
UCF205-14	7/8	3 3/4	2 3/4	5/8	3 5/8	1 1/8	1 1/2	1 1/2	1 3/4	1,3425	0,563	3/8			UC205-14		0,83	
UCF205-15	1 1/16														UC205-15		0,81	
UCF205-16	1														UC205-16		0,80	
UCF206	30	108	83	18	14	31	12	40,2	44,5	38,1	15,9	M10			UC206	F206	1,12	
UCF206-17	1 1/16												18525	10735	UC206-17		1,15	
UCF206-18	1 1/8	4 1/4	3 1/4	4 5/8	3 5/8	1 7/8	1 5/8	1 1 3/8	1 3/4	1,5000	0,626	3/8			UC206-18		1,14	
UCF206-19	1 3/16														UC206-19		1,12	
UCF206-20	1 1/4														UC206-20		1,11	
UCF207	35	117	92	19	16	34	14	44,4	48,5	42,9	17,5	M12			UC207	F207	1,46	
UCF207-20	1 1/4												24415	14630	UC207-20		1,52	
UCF207-21	1 5/16	4 3/8	3 5/8	3/4	5/8	1 1/2	3 5/8	1 3/4	1 2 3/8	1,6890	0,689	7/16			UC207-21		1,49	
UCF207-22	1 3/8														UC207-22		1,46	
UCF207-23	1 1/16														UC207-23		1,43	
UCF208	40	130	102	21	16	36	16	51,2	55,5	49,2	19	M14			UC208	F208	1,84	
UCF208-24	1 1/2	5 1/8	4 1/4	5 3/8	5/8	1 2 7/8	5/8	2 1/4	2 3/8	1,9370	0,748	1/2	27645	16910	UC208-24		1,88	
UCF208-25	1 1/16														UC208-25		1,85	
UCF209	45	137	105	22	18	38	16	52,2	56,5	49,2	19	M14			UC209	F209	2,15	
UCF209-26	1 5/8												32395	20235	UC209-26		2,25	
UCF209-27	1 11/16	5 1/2	4 3/4	5 5/8	2 3/8	1 1/2	5/8	2 1/8	2 3/8	1,9370	0,748	1/2			UC209-27		2,21	
UCF209-28	1 3/4														UC209-28		2,17	
UCF210	50	143	111	22	18	40	16	54,6	59,5	51,6	19	M14			UC210	F210	2,42	
UCF210-29	1 13/16												33345	22135	UC210-29		2,54	
UCF210-30	1 7/8	5 5/8	4 3/8	5 5/8	2 3/8	1 1/8	5/8	2 5/8	2 11/8	2,0315	0,748	1/2			UC210-30		2,49	
UCF210-31	1 15/16														UC210-31		2,44	
UCF210-32	2														UC210-32		2,40	
UCF211	55	162	130	25	20	43	19	58,4	63	55,6	22,2	M16			UC211	F211	3,31	
UCF211-32	2												41230	27930	UC211-32		3,46	
UCF211-33	2 1/16	6 3/8	5 1/8	6 3/8	2 5/8	1 11/16	3/4	1 3/8	2 3/8	2,1890	0,874	5/8			UC211-33		3,40	
UCF211-34	2 1/8														UC211-34		3,35	
UCF211-35	2 3/16														UC211-35		3,29	
UCF212	60	175	143	29	20	48	19	68,7	73,5	65,1	25,4	M16			UC212	F212	4,28	
UCF212-36	2 1/4												49780	34390	UC212-36		4,41	
UCF212-37	2 5/16	6 5/8	5 5/8	1 5/8	2 5/8	1 5 7/8	3/4	2 4 5/8	2 5 7/8	2,5630	1,000	5/8			UC212-37		4,33	
UCF212-38	2 3/8														UC212-38		4,26	
UCF212-39	2 7/16														UC212-39		4,19	
UCF213	65	187	149	30	22	50	19	69,7	74,5	65,1	25,4	M16			UC213	F213	4,99	
UCF213-40	2 1/2	7 2 3/8	5 3 5/8	1 3 1/8	5 5/8	1 3 1/2	3/4	2 3/4	2 1 5/8	2,5630	1,000	5/8	54340	38095	UC213-40		5,08	
UCF213-41	2 9/16														UC213-41		4,99	
UCF214	70	193	152	31	22	54	19	75,4	81,5	74,6	30,2	M16			UC214	F214	5,85	
UCF214-42	2 5/8												59090	41895	UC214-42		6,06	
UCF214-43	2 1 1/16	7 1 3/8	5 6 3/8	1 7 3/8	5 5/8	2 1 3/8	3/4	2 1 3/8	3 1 3/8	2,9370	1,189	5/8			UC214-43		5,96	
UCF214-44	2 3/4														UC214-44		5,86	
UCF215	75	200	159	34	22	56	19	78,5	83,5	77,8	33,3	M16			UC215	F215	6,91	
UCF215-45	2 13/16												64030	45885	UC215-45		7,16	
UCF215-46	2 7/8	7 7/8	6 1 1/8	1 1 1/2	5 5/8	2 7/8	3/4	3 3/8	3 3/8	3,0630	1,311	5/8			UC215-46		7,05	
UCF215-47	2 15/16														UC215-47		6,94	
UCF215-48	3														UC215-48		6,82	
UCF216	80	208	165	34	22	58	23	83,3	88,5	82,6	33,3	M20			UC216	F216	7,50	
UCF216-49	3 1/16												69065	50350	UC216-49		7,68	
UCF216-50	3 3/8	8 3/8	6 1/2	1 1 1/2	5 5/8	2 5/8	2 5/8	3 3/8	3 3 3/8	3,2520	1,311	3/4			UC216-50		7,55	
UCF216-51	3 3/16														UC216-51		7,42	
UCF217	85	220	175	36	24	63	23	87,6	92,6	85,7	34,1	M20			UC217	F217	9,66	
UCF217-52	3 1/4												79800	58805	UC217-52		9,88	
UCF217-53	3 3/8	8 2 3/8	6 3 7/8	1 2 7/8	1 5/8	2 1 3/8	2 5/8	3 7/8	3 4 1/8	3,3740	1,343	3/4			UC217-53		9,74	
UCF217-55	3 7/16														UC217-55		9,45	
UCF218	90	235	187	40	24	68	23	96,3	101,5	96	39,7	M20			UC218	F218	12,06	
UCF218-56	3 1/2	9 1/4	7 2 3/8	1 3 7/8	1 5/8	2 1 1/8	2 5/8	3 2 3/8	4	3,7795	1,5630	3/4	91295	67925	UC218-56		12,17	

Disponibile in acciaio inox Supporto: AISI 304 - Cuscinetto: AISI 440C o 420C - Available stainless steel Housing: AISI 304 - Bearing: AISI 440C or 420C
 Disponibile su richiesta con cuscinetto SA (SAF.) - Available under request with SA bearing (SAF.)

HCF2 Serie normale - Standard duty

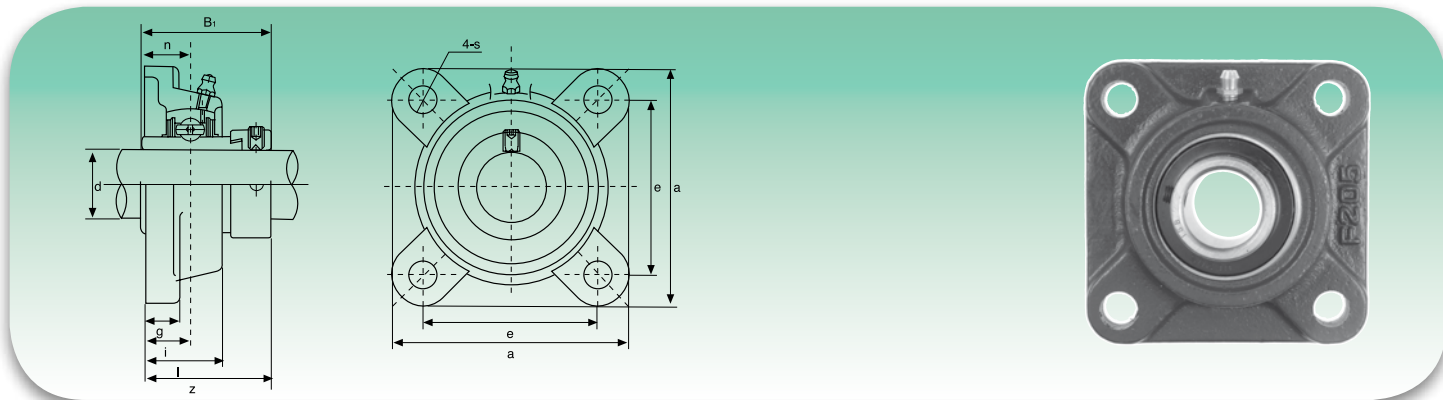

Tipo Type	Dimensioni - Dimensions										Bull. fiss. Bolt Size	Coefficients di carico (N) Load ratings (N)		Cuscinetto Bearing	Supporto Housing	Peso Weight
	d	a	e	i	g	l	s	z	B ₁	n		Dinamico C Dynamic C	Statico C ₀ Static C ₀			
	mm/inch											mm/inch				
HCF204	20	86	64	15	12	25,5	12	41,6	43,7	17,1	M10	12160	6318	HC204	F204	0,63
HCF204-12	3/4	3 3/8	2 3/4	1 9/32	1 5/32	1	1 5/32	1 41/64	1,720	0,673	3/8			HC204-12		0,63
HCF205	25	95	70	16	14	27	12	42,9	44,4	17,5	M10			HC205		0,87
HCF205-13	1 13/16													HC205-13		0,92
HCF205-14	7/8	3 3/4	2 3/4	5/8	3 5/8	1 1/16	1 5/32	1 11/16	1,748	0,689	3/8	13300	7457	HC205-14	F205	0,91
HCF205-15	1 5/16													HC205-15		0,89
HCF205-16	1													HC205-16		0,87
HCF206	30	108	83	18	14	31	12	48,1	48,4	18,3	M10			HC206		1,25
HCF206-17	1 1/8													HC206-17		1,30
HCF206-18	1 1/8	4 1/4	3 17/64	4 5/64	3 5/64	1 7/32	1 5/32	1 57/64	1,906	0,720	3/8	18525	10735	HC206-18	F206	1,27
HCF206-19	1 3/16													HC206-19		1,25
HCF206-20	1 1/4													HC206-20		1,24
HCF207	35	117	92	19	16	34	14	51,3	51,1	18,8	M12			HC207		1,58
HCF207-20	1 1/4													HC207-20		1,65
HCF207-21	1 5/16	4 3 9/64	3 5/8	3/4	5/8	1 11/32	3 5/64	2 1/64	2,012	0,740	7/16	24415	14630	HC207-21	F207	1,61
HCF207-22	1 3/8													HC207-22		1,58
HCF207-23	1 7/16													HC207-23		1,55
HCF208	40	130	102	21	16	36	16	55,9	56,3	21,4	M14			HC208		1,99
HCF208-24	1 1/2	5 1/8	4 1/64	5 3/64	5/8	1 27/32	5/8	2 13/64	2,217	0,843	1/2	27645	16910	HC208-24	F208	2,04
HCF208-25	1 1/16													HC208-25		2,00
HCF209	45	137	105	22	18	38	16	56,9	56,3	21,4	M14			HCF209		2,32
HCF209-26	1 5/8													HC209-26		2,43
HCF209-27	1 11/16	5 13/32	4 9/64	5 5/64	5 5/64	1 1/2	5/8	2 1/64	2,217	0,843	1/2	32395	20235	HC209-27	F209	2,38
HCF209-28	1 3/4													HC209-28		2,34
HCF210	50	143	111	22	18	40	16	60,1	62,7	24,6	M14			HCF210		2,61
HCF210-29	1 13/16													HC210-29		2,76
HCF210-30	1 7/8	5 5/8	4 3/8	5 5/64	5 5/64	1 9/16	5/8	2 3/8	2,469	0,969	1/2	33345	22135	HC210-30	F210	2,70
HCF210-31	1 15/16													HC210-31		2,64
HCF210-32	2													HC210-32		2,58
HCF211	55	162	130	25	20	43	19	68,6	71,4	27,8	M16			HCF211		3,52
HCF211-32	2													HC211-32		3,72
HCF211-33	2 3/16	6 3/8	5 1/8	6 3/64	2 5/32	1 11/16	3/4	2 4 5/64	2,811	1,094	5/8	41230	27930	HC211-33	F211	3,64
HCF211-34	2 1/8													HC211-34		3,57
HCF211-35	2 3/16													HC211-35		3,49
HCF212	60	175	143	29	20	48	19	75,8	77,8	31	M16			HC212		4,62
HCF212-36	2 1/4													HC212-36		4,78
HCF212-37	2 5/16	6 57/64	5 5/8	1 9/64	2 5/32	1 57/64	3/4	2 9 3/64	3,063	1,220	5/8	49780	34390	HC212-37	F212	4,69
HCF212-38	2 3/8													HC212-38		4,64
HCF212-39	2 7/16													HC212-39		4,51
HCF213	65	187	149	30	22	50	19	81,6	85,7	34,1	M16			HC213		5,55
HCF213-40	2 1/2	7 3 3/64	5 5 5/64	1 3 1/16	5 5 5/64	1 3 1/32	3 3/4	3 3 3/32	3,374	1,343	5 5/8	54340	38095	HC213-40	F213	5,65
HCF213-41	2 9/16													HC213-41		5,54
HCF214	70	193	152	31	22	54	19	82,6	85,7	34,1	M16			HC214		6,35
HCF214-42	2 3 3/8													HC214-42		6,59
HCF214-43	2 11/16	7 1 9/32	5 6 3/64	1 7 3/32	5 5 5/64	2 1 8/8	3 3/4	3 1 4/4	3,374	1,343	5 5/8	59090	41895	HC214-43	F214	6,48
HCF214-44	2 3 3/4													HC214-44		6,36
HCF215	75	200	159	34	22	56	19	88,8	92,1	37,3	M16			HC215		7,54
HCF215-45	2 13 3/16													HC215-45		7,84
HCF215-46	2 7 3/8	7 7 3/8	6 1 7/64	1 1 1 3/32	5 5 5/64	2 7 3/32	3 3/4	3 1 1 2	3,626	1,426	5 5/8	64030	45885	HC215-46	F215	7,71
HCF215-47	2 15 1/16													HC215-47		7,58
HCF215-48	3													HC215-48		7,44

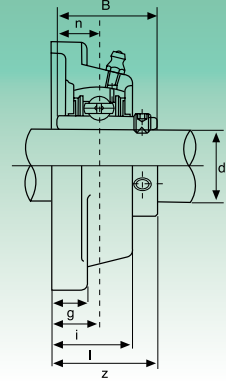
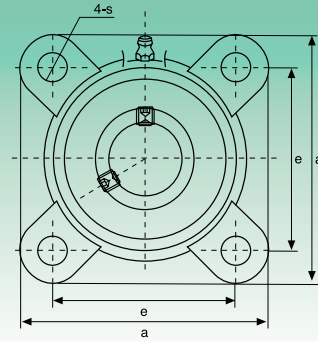

Tipo Type	Dimensioni - Dimensions										Bull. fiss. Bolt Size	Coefficienti di carico (N) Load ratings (N)		Cuscinetto Bearing	Supporto Housing	Peso Weight kg				
	d	a	e	i	g	l	s	z	B	n		Dinamico C Dynamic C	Statico C ₀ Static C ₀							
	mm/inch											mm/inch								
UCF305 UCF305-13 UCF305-14 UCF305-15 UCF305-16	25 1 ³ / ₁₆ 7 ⁷ / ₁₆ 1 ⁵ / ₁₆ 1	110	80	16	13	29	16	39	38	15	M14	20140	10355	UC305 UC305-13 UC305-14 UC305-15 UC305-16	F305	1,1				
UCF306 UCF306-17 UCF306-18 UCF306-19	30 1 ¹ / ₁₆ 1 ¹ / ₁₆ 1 ³ / ₁₆	125	95	18	15	32	16	44	43	17	M14			25365			14250	UC306 UC306-17 UC306-18 UC306-19	F306	1,6
UCF307 UCF307-20 UCF307-21 UCF307-22 UCF307-23	35 1 ¹ / ₄ 1 ⁵ / ₁₆ 1 ³ / ₈ 1 ¹ / ₁₆	135	100	20	16	36	19	49	48	19	M16			31730			18335	UC307 UC307-20 UC307-21 UC307-22 UC307-23	F307	2
UCF308 UCF308-24 UCF308-25	40 1 ¹ / ₂ 1 ¹ / ₈	150	112	23	17	40	19	56	52	19	M16			38665			22800	UC308 UC308-24 UC308-25	F308	2,7
UCF309 UCF309-26 UCF309-27 UCF309-28	45 1 ⁵ / ₁₆ 1 ¹¹ / ₁₆ 1 ³ / ₄	160	125	25	18	44	19	60	57	22	M16			46455			28025	UC309 UC309-26 UC309-27 UC309-28	F309	3,4
UCF310 UCF310-29 UCF310-30 UCF310-31	50 1 ¹³ / ₁₆ 1 ⁷ / ₈ 1 ¹⁵ / ₁₆	175	132	28	19	48	23	67	61	22	M20	58900	36385	UC310 UC310-29 UC310-30 UC310-31	F310	4,5				
UCF311 UCF311-32 UCF311-33 UCF311-34 UCF311-35	55 2 2 ¹ / ₁₆ 2 ¹ / ₈ 2 ³ / ₁₆	185	140	30	20	52	23	71	66	25	M20	68020	42750	UC311 UC311-32 UC311-33 UC311-34 UC311-35	F311	5,5				
UCF312 UCF312-36 UCF312-37 UCF312-38 UCF312-39	60 2 ¹ / ₄ 2 ³ / ₁₆ 2 ³ / ₈ 2 ⁷ / ₁₆	195	150	33	22	56	23	78	71	26	M20	77805	49590	UC312 UC312-36 UC312-37 UC312-38 UC312-39	F312	6,5				
UCF313 UCF313-40 UCF313-41	65 2 ¹ / ₂ 2 ⁹ / ₁₆	208	166	33	22	58	23	78	75	30	M20	88065	56905	UC313 UC313-40 UC313-41	F313	7,9				
UCF314 UCF314-42 UCF314-43 UCF314-44	70 2 ⁵ / ₁₆ 2 ¹ / ₁₆ 2 ³ / ₄	226	178	36	25	61	25	81	78	33	M22	98800	64790	UC314 UC314-42 UC314-43 UC314-44	F314	9,5				
UCF315 UCF315-45 UCF315-46 UCF315-47 UCF315-48	75 2 ¹³ / ₁₆ 2 ⁷ / ₈ 2 ¹ / ₁₆ 3	236	184	39	25	66	25	89	82	32	M22	107350	73340	UC315 UC315-45 UC315-46 UC315-47 UC315-48	F315	12				
UCF316 UCF316-49 UCF316-50 UCF316-51	80 3 ³ / ₁₆ 3 ³ / ₈ 3 ³ / ₁₆	250	196	38	27	68	31	90	86	34	M27	116850	82365	UC316 UC316-49 UC316-50 UC316-51	F316	14				
UCF317 UCF317-52 UCF317-53 UCF317-55	85 3 ³ / ₄ 3 ³ / ₁₆ 3 ⁷ / ₁₆	260	204	44	27	74	31	100	96	40	M27	126350	91960	UC317 UC317-52 UC317-53 UC317-55	F317	16				
UCF318 UCF318-55 UCF318-56	90 3 ⁷ / ₁₆ 3 ¹ / ₂	280	216	44	30	76	35	100	96	40	M30	135850	101650	UC318 UC318-55 UC318-56	F318	19				
UCF319 UCF319-58 UCF319-59 UCF319-60	95 3 ⁵ / ₈ 3 ¹ / ₁₆ 3 ³ / ₄	290	228	59	30	94	35	121	103	41	M30	145350	113050	UC319 UC319-58 UC319-59 UC319-60	F319	22				
UCF320 UCF320-61 UCF320-62 UCF320-63 UCF320-64	100 3 ¹³ / ₁₆ 3 ³ / ₈ 3 ¹ / ₁₆ 4	310	242	59	32	94	38	125	108	42	M33	164350	133950	UC320 UC320-61 UC320-62 UC320-63 UC320-64	F320	25				
UCF321	105	310	242	59	32	94	38	127	-	44	M33	174800	145350	UC321	F321	25,6				
UCF322	110	340	266	60	35	96	41	131	-	46	M36	194750	171000	UC322	F322	34,7				
UCF324	120	370	290	65	40	110	41	140	-	51	M36	196650	175750	UC324	F324	47,2				
UCF326	130	410	320	65	45	115	41	146	-	54	M36	217550	203300	UC326	F326	62,7				
UCF328	140	450	350	75	55	125	41	161	-	59	M36	240350	233700	UC328	F328	87,0				

UCFS3 Serie pesante - Heavy duty

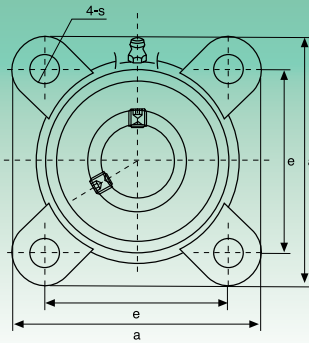
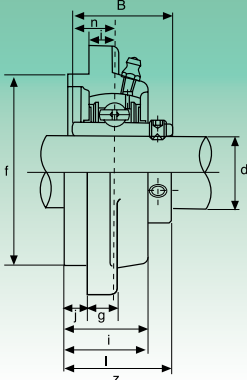

Tipo Type	Dimensioni - Dimensions												Bull. fiss. Bolt Size	Coefficienti di carico (N) Load ratings (N)		Cuscinetto Bearing	Supporto Housing	Peso Weight										
	d	a	e	i	s	j	g	l	f	z	B	n		Dinamico C Dynamic C	Statico C ₀ Static C ₀				kg									
	mm/inch													mm/inch														
UCFS305 UCFS305-13 UCFS305-14 UCFS305-15 UCFS305-16	25 1 3/16 7/16 1 1/16 1	110	80	9	16	7	13	29	80	39	38	15	M14	20140	10355	UC305 UC305-13 UC305-14 UC305-15 UC305-16	FS305	1,3										
UCFS306 UCFS306-17 UCFS306-18 UCFS306-19	30 1 1/16 1 1/8 1 3/16	125	95	10	16	8	15	32	90	44	43	17	M14						25365	14250	UC306 UC306-17 UC306-18 UC306-19	FS306	1,9					
UCFS307 UCFS307-20 UCFS307-21 UCFS307-22 UCFS307-23	35 1 1/4 1 5/16 1 3/8 1 7/16	135	100	11	19	9	16	36	100	49	48	19	M16											31730	18335	UC307 UC307-20 UC307-21 UC307-22 UC307-23	FS307	2,4
UCFS308 UCFS308-24 UCFS308-25	40 1 1/2 1 9/16	150	112	13	19	10	17	40	115	56	52	19	M16															
UCFS309 UCFS309-26 UCFS309-27 UCFS309-28	45 1 3/8 1 11/16 1 3/4	160	125	14	19	11	18	44	125	60	57	22	M16						46455	28020	UC309 UC309-26 UC309-27 UC309-28	FS309	4,0					
UCFS310 UCFS310-29 UCFS310-30 UCFS310-31	50 1 13/16 1 7/8 1 15/16	175	132	16	23	12	19	48	140	67	61	22	M20	58900	36385	UC310 UC310-29 UC310-30 UC310-31	FS310	5,3										
UCFS311 UCFS311-32 UCFS311-33 UCFS311-34 UCFS311-35	55 2 2 1/16 2 1/8 2 3/16	185	140	17	23	13	20	52	150	71	66	26	M20											68020	42750	UC311 UC311-32 UC311-33 UC311-34 UC311-35	FS311	6,2
UCFS312 UCFS312-36 UCFS312-37 UCFS312-38 UCFS312-39	60 2 1/4 2 5/16 2 3/8 2 7/16	195	150	19	23	14	22	56	160	78	71	25	M20						77805	49590	UC312 UC312-36 UC312-37 UC312-38 UC312-39	FS312	7,2					
UCFS313 UCFS313-40 UCFS313-41	65 2 1/2 2 9/16	208	166	15	23	18	22	58	175	78	75	30	M20															
UCFS314 UCFS314-42 UCFS314-43 UCFS314-44	70 2 5/8 2 11/16 2 3/4	223	178	18	25	18	25	61	185	81	78	33	M20	98800	64790	UC314 UC314-42 UC314-43 UC314-44	FS314	11										
UCFS315 UCFS315-45 UCFS315-46 UCFS315-47 UCFS315-48	75 2 13/16 2 7/8 2 9/16 3	236	184	21	25	18	25	66	200	89	82	32	M22															
UCFS316 UCFS316-49 UCFS316-50 UCFS316-51	80 3 1/16 3 1/8 3 3/16	250	196	18	31	20	27	68	210	90	86	34	M27						116850	82365	UC316 UC316-49 UC316-50 UC316-51	FS316	15					
UCFS317 UCFS317-52 UCFS317-53 UCFS317-55	85 3 1/4 3 3/16 3 7/16	260	204	24	31	20	27	74	220	100	96	40	M27	126350	91960	UC317 UC317-52 UC317-53 UC317-55	FS317	17										
UCFS318 UCFS318-55 UCFS318-56	90 3 3/16 3 1/2	280	216	24	35	20	30	76	240	100	96	40	M30											135850	101650	UC318 UC318-55 UC318-56	FS318	21
UCFS319 UCFS319-58 UCFS319-59 UCFS319-60	95 3 3/8 3 11/16 3 3/4	280	228	39	35	20	30	94	250	121	103	41	M30						145350	113050	UC319 UC319-58 UC319-59 UC319-60	FS319	25					
UCFS320 UCFS320-61 UCFS320-62 UCFS320-63 UCFS320-64	100 3 13/16 3 7/8 3 15/16 4	310	242	39	38	20	32	94	260	125	108	42	M33											164350	133950	UC320 UC320-61 UC320-62 UC320-63 UC320-64	FS320	30

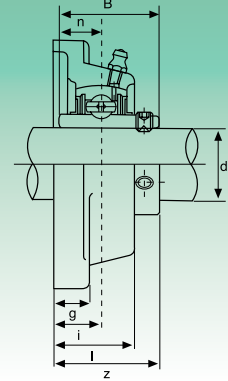
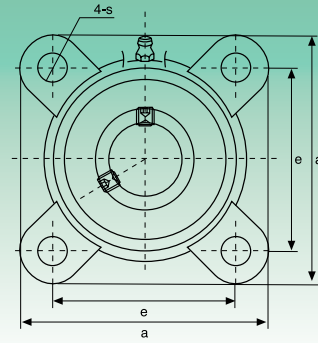

Tipo Type	Dimensioni - Dimensions										Bull. fiss. Bolt Size	Coefficienti di carico (N) Load ratings (N)		Cuscinetto Bearing	Supporto Housing	Peso Weight kg
	d	a	e	i	g	l	s	z	B	n		Dinamico C Dynamic C	Statico C ₀ Static C ₀			
	mm/inch											mm/inch				
UCFX05 UCFX05-13 UCFX05-14 UCFX05-15 UCFX05-16	25 1 ¹³ / ₁₆ 7 ⁷ / ₁₆ 1 ¹⁵ / ₁₆ 1	108	83	18	13	30	12	40,2	38,1	15,9	M10	18525	10735	UCX05 UCX05-13 UCX05-14 UCX05-15 UCX05-16	FX05	1,0
UCFX06 UCFX06-17 UCFX06-18 UCFX06-19 UCFX06-20	30 1 ¹¹ / ₁₆ 1 ¹³ / ₁₆ 1 ¹³ / ₁₆ 1 ¹⁴ / ₁₆	117	92	19	14	34	16	44,4	42,9	17,5	M14	24415	14630	UCX06 UCX06-17 UCX06-18 UCX06-19 UCX06-20	FX06	1,7
UCFX07 UCFX07-21 UCFX07-22 UCFX07-23	35 1 ¹³ / ₁₆ 1 ¹³ / ₁₆ 1 ¹³ / ₁₆	130	102	21	14	38	16	51,2	49,2	19	M14	27645	16910	UCX07 UCX07-21 UCX07-22 UCX07-23	FX07	2,1
UCFX08 UCFX08-24 UCFX08-25	40 1 ¹² / ₁₆ 1 ¹³ / ₁₆	137	105	22	14	40	19	52,2	49,2	19	M16	32395	20235	UCX08 UCX08-24 UCX08-25	FX08	2,4
UCFX09 UCFX09-26 UCFX09-27 UCFX09-28 UCFX09-29	45 1 ¹⁵ / ₁₆ 1 ¹¹ / ₁₆ 1 ¹³ / ₁₆ 1 ¹³ / ₁₆	143	111	23	14	40	19	55,6	51,6	19	M16	33345	22135	UCX09 UCX09-26 UCX09-27 UCX09-28 UCX09-29	FX09	2,5
UCFX10 UCFX10-30 UCFX10-31 UCFX10-32	50 1 ¹⁷ / ₁₆ 1 ¹⁵ / ₁₆ 2	162	130	26	20	44	19	59,4	55,6	22,2	M16	41230	27930	UCX10 UCX10-30 UCX10-31 UCX10-32	FX10	3,9
UCFX11 UCFX11-33 UCFX11-34 UCFX11-35 UCFX11-36 UCFX11-37	55 2 ¹ / ₁₆ 2 ¹ / ₁₆ 2 ³ / ₁₆ 2 ¹ / ₁₆ 2 ⁵ / ₁₆	175	143	29	20	49	19	68,7	65,1	25,4	M16	49780	34390	UCX11 UCX11-33 UCX11-34 UCX11-35 UCX11-36 UCX11-37	FX11	4,9
UCFX12 UCFX12-38 UCFX12-39	60 2 ³ / ₁₆ 2 ⁷ / ₁₆	187	149	34	21	59	19	73,7	65,1	25,4	M16	54340	38095	UCX12 UCX12-38 UCX12-39	FX12	5,2
UCFX13 UCFX13-40 UCFX13-41	65 2 ¹ / ₂ 2 ⁹ / ₁₆	187	149	34	21	59	19	78,4	74,6	30,2	M16	59090	41895	UCX13 UCX13-40 UCX13-41	FX13	5,3
UCFX14 UCFX14-42 UCFX14-43 UCFX14-44	70 2 ⁵ / ₁₆ 2 ¹¹ / ₁₆ 2 ³ / ₄	197	152	37	24	60	23	81,5	77,8	33,3	M20	64030	45885	UCX14 UCX14-42 UCX14-43 UCX14-44	FX14	7,3
UCFX15 UCFX15-45 UCFX15-46 UCFX15-47 UCFX15-48	75 2 ¹³ / ₁₆ 2 ⁷ / ₁₆ 2 ¹⁵ / ₁₆ 3	197	152	40	24	68	23	89,3	82,6	33,3	M20	69065	50350	UCX15 UCX15-45 UCX15-46 UCX15-47 UCX15-48	FX15	8,1
UCFX16 UCFX16-49 UCFX16-50 UCFX16-51 UCFX16-52	80 3 ¹ / ₁₆ 3 ³ / ₁₆ 3 ³ / ₁₆ 3 ³ / ₄	214	171	40	24	70	23	91,6	85,7	34,1	M20	79800	58805	UCX16 UCX16-49 UCX16-50 UCX16-51 UCX16-52	FX16	9,9
UCFX17 UCFX17-53 UCFX17-55	85 3 ³ / ₁₆ 3 ³ / ₁₆	214	171	40	24	70	23	93,3	96	39,7	M20	91295	67925	UCX17 UCX17-53 UCX17-55	FX17	11
UCFX18 UCFX18-56 UCFX18-57	90 3 ⁷ / ₁₆ 3 ¹ / ₂	214	171	45	24	76	23	106,1	104	42,9	M20	103550	77805	UCX18 UCX18-56 UCX18-57	FX18	11
UCFX20 UCFX20-58 UCFX20-59 UCFX20-60 UCFX20-61	100 3 ¹³ / ₁₆ 3 ⁷ / ₁₆ 3 ¹⁵ / ₁₆ 4	268	211	59	31	97	31	127,3	117,5	49,2	M27	126350	99750	UCX20 UCX20-58 UCX20-59 UCX20-60 UCX20-61	FX20	17

UKF2 Serie normale - Standard duty

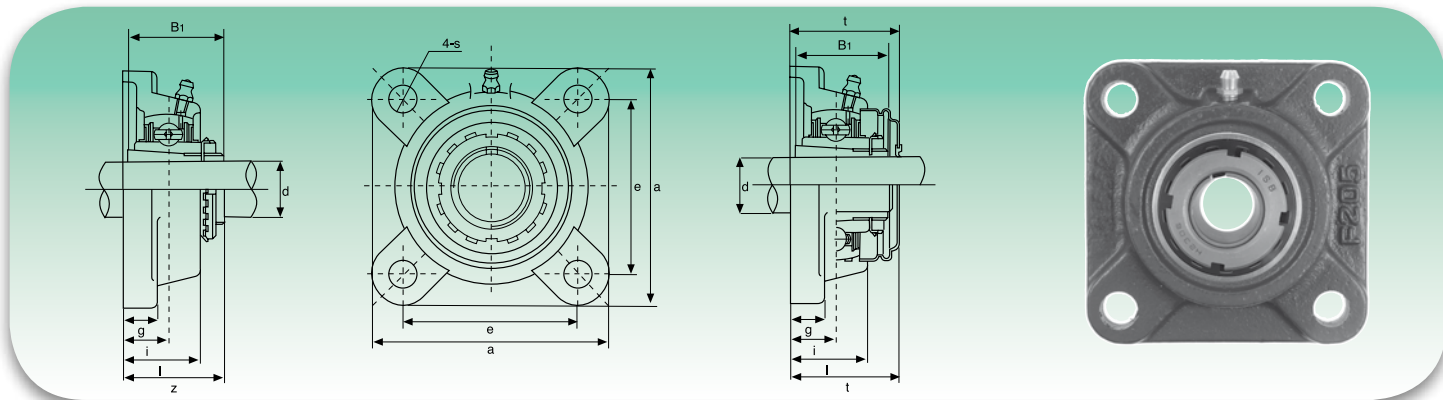

Tipo Type	Dimensioni - Dimensions										Bull. fiss. Bolt Size	Coefficienti di carico (N) Load ratings (N)		Cuscinetto Bearing	Supporto Housing	Peso Weight	
	d	a	e	i	g	l	s	z	t	B ₁		Dinamico C Dynamic C	Statico C ₀ Static C ₀				kg
	mm/inch											mm/inch					
UKF205+H2305	20	95	70	16	14	27	12	35,5	40	35	M10			UK205+H2305	F205	0,85	
UKF205+HE2305	¾	3¾	2¾	⅝	⅜	1⅛	1½	1⅝	1⅞	1⅞	⅜	13300	7457	UK205+HE2305			
UKF206+H2306	25	108	83	18	14	31	12	39	44,5	38	M10			UK206+H2306	F206	1,16	
UKF206+HS2306	⅞	4¼	3⅞	⅝	⅜	1⅞	1½	1⅞	2¼	1¾	⅜	18525	10735	UK206+HS2306			
UKF206+HE2306	1													UK206+HE2306			
UKF207+H2307	30	117	92	19	16	34	14	42,5	48,5	43	M12			UK207+H2307	F207	1,55	
UKF207+HS2307	1⅞	4⅜	3⅞	¾	⅝	1⅞	⅜	1⅞	2⅞	1⅞	⅞	24415	14630	UK207+HS2307			
UKF208+H2308	35	130	102	21	16	36	16	46,5	55,5	46	M14			UK208+H2308	F208	1,94	
UKF208+HE2308	1¼	5⅞	4⅞	⅝	⅝	1⅞	⅝	1⅞	2⅞	1⅞	½	27645	16910	UK208+HE2308			
UKF208+HS2308	1⅜													UK208+HS2308			
UKF209+H2309	40	137	105	22	18	38	16	48,5	56,5	50	M14			UK209+H2309	F209	2,30	
UKF209+HA2309	1⅞											32395	20235	UK209+HA2309			
UKF209+HE2309	1½	5⅞	4⅞	⅝	⅜	1⅞	⅝	1⅞	2⅞	1⅞	½			UK209+HE2309			
UKF209+HS2309	1⅝													UK209+HS2309			
UKF210+H2310	45	143	111	22	18	40	16	50	59,5	55	M14			UK210+H2310	F210	2,59	
UKF210+HS2310	1⅝											33345	22135	UK210+HS2310			
UKF210+HA2310	1⅞	5⅞	4⅞	⅝	⅜	1⅞	⅝	1⅞	2⅞	1⅞	½			UK210+HA2310			
UKF210+HE2310	1¾													UK210+HE2310			
UKF211+H2311	50	162	130	25	20	43	19	54,5	63	59	M16			UK211+H2311	F211	3,46	
UKF211+HS2311	1⅞											41230	27930	UK211+HS2311			
UKF211+HA2311	1⅞	6⅞	5⅞	⅝	⅜	1⅞	¾	2⅞	3⅞	2⅞	⅝			UK211+HA2311			
UKF211+HE2311	2													UK211+HE2311			
UKF212+H2312	55	175	143	29	20	48	19	61	73,5	62	M16			UK212+H2312	F212	4,33	
UKF212+HS2312	2⅞	6⅞	5⅞	1⅞	⅜	1⅞	¾	2⅞	3⅞	2⅞	⅝	49780	34390	UK212+HS2312			
UKF213+H2313	60	187	149	30	22	50	19	64	74,5	65	M16			UK213+H2313	F213	4,90	
UKF213+HA2313	2¾											54340	38095	UK213+HA2313			
UKF213+HE2313	2¼	7⅞	5⅞	1⅞	⅜	1⅞	¾	2⅞	3⅞	2⅞	⅝			UK213+HE2313			
UKF213+HS2313	2⅝													UK213+HS2313			
UKF215+H2315	65	200	159	34	22	56	19	71	83,5	73	M16			UK215+H2315	F215	7,02	
UKF215+HA2315	2⅞											64030	45885	UK215+HA2315			
UKF215+HE2315	2½	7⅞	6⅞	1⅞	⅜	1⅞	¾	2⅞	3⅞	2⅞	⅝			UK215+HE2315			
UKF216+H2316	70	208	165	34	22	58	23	73,5	88,5	78	M20			UK216+H2316	F216	7,76	
UKF216+HA2316	2⅞	8⅞	6½	1⅞	⅜	1⅞	¾	2⅞	3⅞	3⅞	¾	69065	50350	UK216+HA2316			
UKF216+HE2316	2¾													UK216+HE2316			
UKF217+H2317	75	220	175	36	24	63	23	77	92,6	82	M20			UK217+H2317	F217	10,08	
UKF217+HA2317	2⅞	8⅞	6⅞	1⅞	⅜	1⅞	¾	2⅞	3⅞	3⅞	¾	79800	58805	UK217+HA2317			
UKF217+HE2317	3													UK217+HE2317			
UKF218+H2318	80	235	187	40	24	68	23	81,5	101,5	86	M20			UK218+H2318	F218	12,44	
UKF218+HA2318	3⅞	9¼	7⅞	1⅞	⅜	1⅞	¾	2⅞	3⅞	4	¾	91295	67925	UK218+HA2318			

Bussole HA; HE; HS con filettatura in pollici
Inch dimension adapter sleeves HA; HE; HS

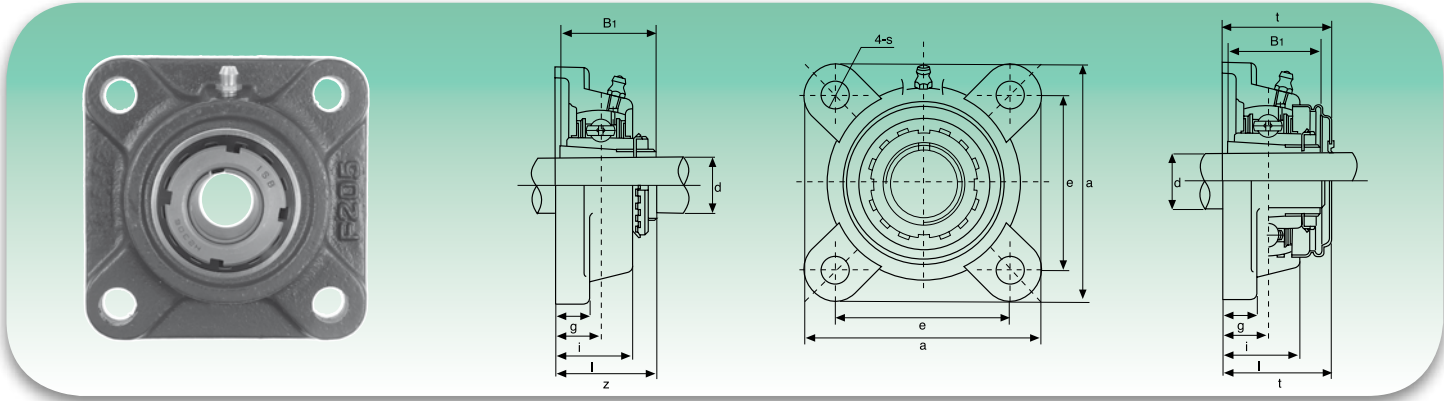
UKF3 Serie pesante - Heavy duty

Tipo Type	Dimensioni - Dimensions									Bull. fiss. Bolt Size	Coefficienti di carico (N) Load ratings (N)		Cuscinetto Bearing	Supporto Housing	Peso Weight kg
	d	a	e	i	g	l	s	z	B ₁		Dinamico C Dynamic C	Statico C ₀ Static C ₀			
	mm/inch										mm/inch				
UKF305+H2305	20	110	80	16	13	29	16	37	35	M14	20140	10355	UK305+H2305	F305	1,4
UKF305+HE2305	¾	4 1/32	3 5/32	5/8	1/2	1 5/32	5/8	1 29/64	1,378	1/2			UK305+HE2305		
UKF306+H2306	25	125	95	18	15	32	16	40,5	38	M14			UK306+H2306	F306	1,9
UKF306+HS2306	7/8										25365	14250	UK306+HS2306		
UKF306+HE2306	1	4 29/32	3 47/64	4 5/64	1 9/32	1 1/4	5/8	2 19/32	1,496	1/2			UK306+HE2306		
UKF307+H2307	30	135	100	20	16	36	19	44,5	43	M16	31730	18335	UK307+H2307	F307	2,3
UKF307+HS2307	1 1/8	5 3/16	3 15/16	2 5/32	5/8	1 13/32	3/4	2 3/4	1,693	5/8			UK307+HS2307		
UKF308+H2308	35	150	112	23	17	40	19	50	46	M16			UK308+H2308	F308	3,1
UKF308+HE2308	1 1/4										38665	22800	UK308+HE2308		
UKF308+HS2308	1 3/8	5 29/32	4 13/32	2 9/32	2 1/2	1 1/16	3/4	2 31/32	1,811	5/8			UK308+HS2308		
UKF309+H2309	40	160	125	25	18	44	19	54,5	50	M16			UK309+H2309	F309	4,1
UKF309+HA2309	1 7/16										46455	28025	UK309+HA2309		
UKF309+HE2309	1 1/2	6 1/16	4 59/64	6 3/64	2 3/32	1 23/32	3/4	2 5/64	1,969	5/8			UK309+HE2309		
UKF309+HS2309	1 5/8												UK309+HS2309		
UKF310+H2310	45	175	132	28	19	48	23	60	55	M20			UK310+H2310	F310	5,1
UKF310+HS2310	1 5/8										58900	36385	UK310+HS2310		
UKF310+HA2310	1 11/16	6 7/8	5 13/64	1 7/64	3/4	1 7/8	2 9/32	2 23/64	2,165	3/4			UK310+HA2310		
UKF310+HE2310	1 3/4												UK310+HE2310		
UKF311+H2311	50	185	140	30	20	52	23	63,5	59	M20			UK311+H2311	F311	5,9
UKF311+HS2311	1 7/8										68020	42750	UK311+HS2311		
UKF311+HA2311	1 15/16	7 9/32	5 33/64	1 3/16	2 5/32	2 1/16	2 9/32	2 1/2	2,323	3/4			UK311+HA2311		
UKF311+HE2311	2												UK311+HE2311		
UKF312+H2312	55	195	150	33	22	56	23	69	62	M20			UK312+H2312	F312	6,8
UKF312+HS2312	2 1/8	7 11/16	5 29/32	1 19/64	7/8	2 7/32	2 9/32	2 23/32	2,441	3/4	77805	49590	UK312+HS2312		
UKF313+H2313	60	208	166	33	22	58	23	71	65	M20			UK313+H2313	F313	7,9
UKF313+HA2313	2 3/16										88065	56905	UK313+HA2313		
UKF313+HE2313	2 1/4	8 3/16	6 17/32	1 19/64	7/8	2 9/32	2 9/32	2 51/64	2,559	3/4			UK313+HE2313		
UKF313+HS2313	2 3/8												UK313+HS2313		
UKF315+H2315	65	236	184	39	25	66	25	81	73	M22			UK315+H2315	F315	11,7
UKF315+HA2315	2 7/16										107350	73340	UK315+HA2315		
UKF315+HE2315	2 1/2	9 9/32	7 1/4	1 17/32	6 3/64	2 19/32	6 3/64	3 3/16	2,874	7/8			UK315+HE2315		
UKF316+H2316	70	250	196	38	27	68	31	83,5	78	M27			UK316+H2316	F316	12,9
UKF316+HA2316	2 11/16										116850	82365	UK316+HA2316		
UKF316+HE2316	2 3/4	9 27/32	7 23/32	1 1/2	1 1/16	2 11/16	1 7/32	3 3/32	3,071	1			UK316+HE2316		
UKF317+H2317	75	260	204	44	27	74	31	92	82	M27			UK317+H2317	F317	15,2
UKF317+HA2317	2 15/16										126350	91960	UK317+HA2317		
UKF317+HS2317	3	10 1/4	8 1/32	1 47/64	1 1/16	2 29/32	3 3/8	3 3/8	3,228	1			UK317+HS2317		
UKF318+H2318	80	280	216	44	30	76	35	93,5	86	M30			UK318+H2318	F318	19
UKF318+HA2318	3 3/16	11 1/32	8 1/2	1 47/64	1 3/16	3	1 3/8	3 1/16	3,386	1 1/8	135850	101650	UK318+HA2318		
UKF319+H2319	85	290	228	59	30	94	35	111	90	M30			UK319+H2319	F319	21,9
UKF319+HA2319	3 5/16	11 13/32	8 33/32	2 21/64	1 3/16	3 11/16	1 3/8	4 3/8	3,543	1 1/8	145350	113050	UK319+HA2319		
UKF320+H2320	90	310	242	59	32	94	38	115	97	M33			UK320+H2320	F320	25,4
UKF320+HA2320	3 7/16	12 7/32	9 17/32	2 21/64	1 1/4	3 11/16	1 1/2	4 17/32	3,814	1 1/4	164350	133950	UK320+HA2320		
UKF322+H2322	100	340	266	60	35	96	41	121	105	M36			UK322+H2322	F322	35,2
UKF322+HA2322	3 15/16	13 3/8	10 15/32	3 23/64	1 3/8	3 25/32	1 39/64	4 49/64	4,134	1 3/8	194750	171000	UK322+HA2322		
UKF324+H2324	110	370	290	65	40	110	41	130	112	M36			UK324+H2324	F324	47,6
UKF324+HA2324	4 3/16	16 5/32	12 19/32	2 9/16	1 1/16	4 11/32	1 39/64	5 1/8	4,410	1 3/8	196650	175750	UK324+HA2324		
UKF326+H2326	115	410	320	65	45	115	41	134	121	M36			UK326+H2326	F326	65,3
UKF326+HA2326	4 7/16	16 5/32	12 19/32	2 9/16	1 25/32	4 17/32	1 39/64	5 9/32	4,764	1 3/8	217550	203300	UK326+HA2326		
UKF328+H2328	125	450	350	75	55	125	41	148	131	M36			UK328+H2328	F328	93,4
UKF328+HA2328	4 15/16	17 23/32	13 29/32	2 61/64	2 9/32	4 29/32	1 39/64	5 53/64	5,158	1 3/8	240350	233700	UK328+HA2328		

Bussole HA; HE; HS con filettatura in pollici
Inch dimension adapter sleeves HA; HE; HS

UKFX Serie media - Medium duty

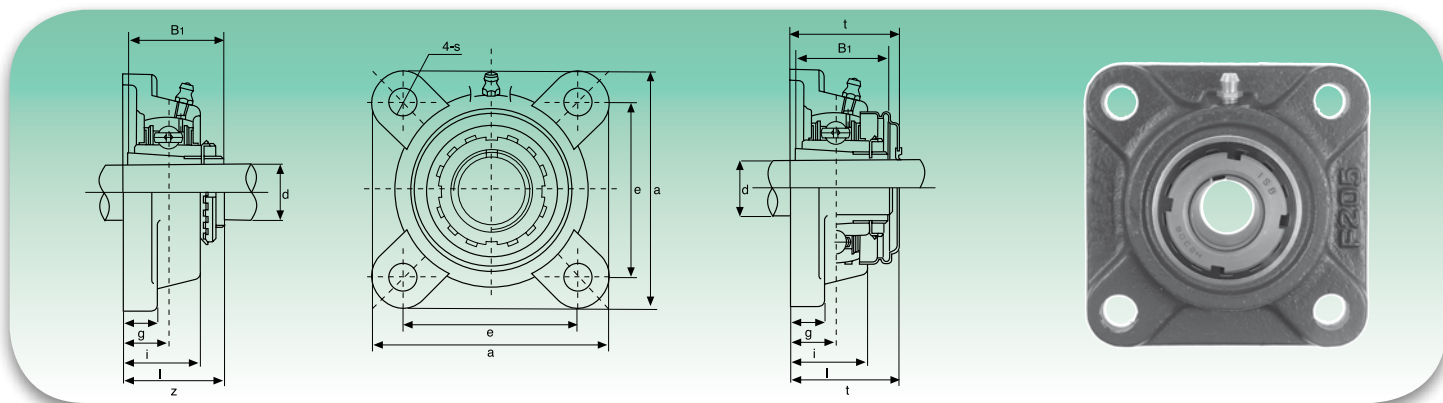

Tipo Type	Dimensioni - Dimensions									Bull. fiss. Bolt Size	Coefficients di carico (N) Load ratings (N)		Cuscinetto Bearing	Supporto Housing	Peso Weight	
	d	a	e	i	g	l	s	z	B ₁		Dinamico C Dynamic C	Statico C ₀ Static C ₀				kg
	mm/inch										mm/inch					
UKFX05+H2305	20	108	83	18	13	30	12	39	35	M10	18525	10735	UKX05+H2305	FX05	1,2	
UKFX05+HE2305	¾	4¼	3 ¹⁷ / ₆₄	4 ⁵ / ₆₄	½	1 ³ / ₁₆	1 ⁵ / ₃₂	1 ¹⁷ / ₃₂	1,378	¾			UKX05+HE2305			
UKFX06+H2306	25	117	92	19	14	34	16	41,5	38	M14	24415	14630	UKX06+H2306	FX06	1,6	
UKFX06+HS2306	7/8												UKX06+HS2306			
UKFX06+HE2306	1	4 ³⁹ / ₆₄	3 ⁵ / ₈	¾	9/16	1 ¹¹ / ₃₂	5/8	1 ⁴¹ / ₆₄	1,496	½			UKX06+HE2306			
UKFX07+H2307	30	130	102	21	14	38	16	45,5	43	M14	27645	16910	UKX07+H2307	FX07	2,0	
UKFX07+HS2307	1 1/8												UKX07+HS2307			
UKFX07+HE2307	1 1/8	5 1/8	4 1/4	5 3/64	9/16	1 1/2	5/8	1 5 1/64	1,693	1/2			UKX07+HE2307			
UKFX08+H2308	35	137	105	22	14	40	19	47,5	46	M16	32395	20235	UKX08+H2308	FX08	2,3	
UKFX08+HE2308	1 1/4												UKX08+HE2308			
UKFX08+HS2308	1 3/8	5 13 3/32	4 3/64	5 5/64	9/16	1 1/16	3/4	1 7/8	1,811	5/8			UKX08+HS2308			
UKFX09+H2309	40	143	111	23	14	40	19	50	50	M16	33345	22135	UKX09+H2309	FX09	2,7	
UKFX09+HA2309	1 5/8												UKX09+HA2309			
UKFX09+HE2309	1 1/2	5 5/8	4 3/8	2 9/32	9/16	1 1/16	3/4	1 3 1/32	1,969	5/8			UKX09+HE2309			
UKFX09+HS2309	1 5/8												UKX09+HS2309			
UKFX10+H2310	45	162	130	26	20	44	19	55,5	55	M16	41230	27930	UKX10+H2310	FX10	3,6	
UKFX10+HS2310	1 5/8												UKX10+HS2310			
UKFX10+HA2310	1 11/16	6 3/8	5 1/8	1 1/2	2 5/32	1 2 3/32	3/4	2 3/16	2,165	5/8			UKX10+HA2310			
UKFX10+HE2310	1 3/4												UKX10+HE2310			
UKFX11+H2311	50	175	143	29	20	49	19	60	59	M16	49780	34390	UKX11+H2311	FX11	4,6	
UKFX11+HS2311	1 5/8												UKX11+HS2311			
UKFX11+HA2311	1 15/16	6 57/64	5 5/8	1 5/64	2 5/32	1 15/16	3/4	2 23/64	2,323	5/8			UKX11+HA2311			
UKFX11+HE2311	2												UKX11+HE2311			
UKFX12+H2312	55	187	149	34	21	59	19	67	62	M16	54340	38095	UKX12+H2312	FX12	5,5	
UKFX12+HS2312	2 1/8	7 23/64	5 55/64	1 11/32	1 3/16	2 5/16	3/4	2 41/64	2,441	5/8			UKX12+HS2312			
UKFX13+H2313	60	187	149	34	21	59	19	68	65	M16	59090	41895	UKX13+H2313	FX13	6,0	
UKFX13+HA2313	2 3/16												UKX13+HA2313			
UKFX13+HE2313	2 1/4	7 23/64	5 55/64	1 11/32	1 3/16	2 5/16	3/4	2 11/16	2,559	5/8			UKX13+HE2313			
UKFX13+HS2313	2 3/8												UKX13+HS2313			
UKFX15+H2315	65	197	152	40	24	68	23	77,5	73	M20	69065	50350	UKX15+H2315	FX15	8,1	
UKFX15+HA2315	2 5/16												UKX15+HA2315			
UKFX15+HE2315	2 1/2	7 3/4	5 63/64	1 37/64	1 5/16	2 11/16	2 9/32	2 3/64	2,874	3/4			UKX15+HE2315			
UKFX16+H2316	70	214	171	40	24	70	23	80	78	M20	79800	58805	UKX16+H2316	FX16	9,5	
UKFX16+HA2316	2 11/16												UKX16+HA2316			
UKFX16+HE2316	2 3/4	8 7/16	6 47/64	1 37/64	1 5/16	2 3/4	2 9/32	3 3/32	3,071	3/4			UKX16+HE2316			
UKFX17+H2317	75	214	171	40	24	70	23	81,5	82	M20	91295	67925	UKX17+H2317	FX17	10,4	
UKFX17+HA2317	2 15/16												UKX17+HA2317			
UKFX17+HE2317	3	8 7/16	6 47/64	1 37/64	1 5/16	2 3/4	2 9/32	3,228	3 3/4	3/4			UKX17+HE2317			
UKFX18+H2318	80	214	171	45	24	76	23	88	86	M20	103550	77805	UKX18+H2318	FX18	11,4	
UKFX18+HA2318	3 3/16												UKX18+HA2318			
UKFX18+HE2318	3 1/2	8 7/16	6 47/64	1 49/64	1 5/16	3	2 9/32	3 15/32	3,386	3/4			UKX18+HE2318			
UKFX20+H2320	90	268	211	59	31	97	31	106	97	M27	126350	99750	UKX20+H2320	FX20	18,4	
UKFX20+HA2330	3 1/2	10 9/16	8 5/16	2 21/64	1 7/32	3 13/32	1 7/32	4 3/64	3,814	1			UKX20+HA2330			

Bussole HA; HE; HS con filettatura in pollici
Inch dimension adapter sleeves HA; HE; HS

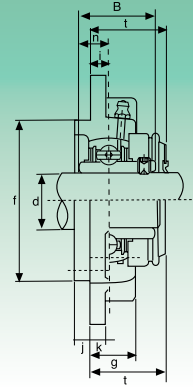
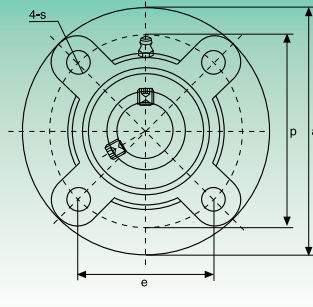
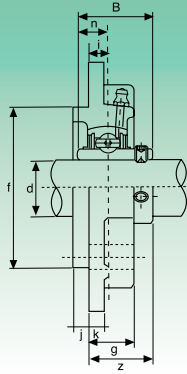

Tipo Type	Dimensioni - Dimensions													Bull. fiss. Bolt Size	Coefficients di carico (N) Load ratings (N)		Cuscinetto Bearing	Supporto Housing	Peso Weight		
	d	a	p	e	i	s	j	k	g	f	z	t	B		n	Dinamico C Dynamic C				Statico C ₀ Static C ₀	kg
	mm/inch														mm/inch						
UCFC201	12	100	78	55,1	10	12	5	7	20,5	62	28,3	32,5	31	12,7	M10	12160	6318	UC201	FC204	0,73	
UCFC201-8	3/4	3 15/16	3 3/4	2 11/64	25/64	1 5/32	13/64	9/32	13/16	2,4409	1 1/8	1 1/32	1,2205	0,500	3/8	12160	6318	UC201-8	FC204	0,72	
UCFC202	15	100	78	55,1	10	12	5	7	20,5	62	28,3	32,5	31	12,7	M10	12160	6318	UC202	FC204	0,72	
UCFC202-9	9/16	3 15/16	3 3/4	2 11/64	25/64	1 5/32	13/64	9/32	13/16	2,4409	1 1/8	1 1/32	1,2205	0,500	3/8	12160	6318	UC202-9	FC204	0,72	
UCFC202-10	5/8	3 15/16	3 3/4	2 11/64	25/64	1 5/32	13/64	9/32	13/16	2,4409	1 1/8	1 1/32	1,2205	0,500	3/8	12160	6318	UC202-10	FC204	0,72	
UCFC203	17	100	78	55,1	10	12	5	7	20,5	62	28,3	32,5	31	12,7	M10	12160	6318	UC203	FC204	0,71	
UCFC203-11	1 1/16	3 15/16	3 3/4	2 11/64	25/64	1 5/32	13/64	9/32	13/16	2,4409	1 1/8	1 1/32	1,2205	0,500	3/8	12160	6318	UC203-11	FC204	0,70	
UCFC204	20	100	78	55,1	10	12	5	7	20,5	62	28,3	32,5	31	12,7	M10	12160	6318	UC204	FC204	0,69	
UCFC204-12	3/4	3 15/16	3 3/4	2 11/64	25/64	1 5/32	13/64	9/32	13/16	2,4409	1 1/8	1 1/32	1,2205	0,500	3/8	12160	6318	UC204-12	FC204	0,69	
UCFC205	25	115	90	63,6	10	12	6	7	21	70	29,8	34	34,1	14,3	M10	13300	7457	UC205	FC205	1,00	
UCFC205-13	1 3/16															13300	7457	UC205-13	FC205	1,04	
UCFC205-14	7/8	4 17/32	3 35/64	2 1/2	25/64	1 5/32	1 5/64	9/32	5 3/64	2,7559	1 11/64	1 11/32	1,3425	0,563	3/8	13300	7457	UC205-14	FC205	1,03	
UCFC205-15	15/16															13300	7457	UC205-15	FC205	1,01	
UCFC205-16	1															13300	7457	UC205-16	FC205	1,00	
UCFC206	30	125	100	70,7	10	12	8	8	23	80	32,2	36,5	38,1	15,9	M10	18525	10735	UC206	FC206	1,30	
UCFC206-17	1 1/16															18525	10735	UC206-17	FC206	1,31	
UCFC206-18	1 1/8	4 59/64	3 15/16	2 25/32	25/64	1 5/32	5/16	5/16	2 9/32	3,1496	1 11/64	1 1/16	1,5000	0,626	3/8	18525	10735	UC206-18	FC206	1,32	
UCFC206-19	1 3/16															18525	10735	UC206-19	FC206	1,30	
UCFC206-20	1 1/4															18525	10735	UC206-20	FC206	1,29	
UCFC207	35	135	110	77,8	11	14	8	9	26	90	36,4	41	42,9	17,5	M12	24415	14630	UC207	FC207	1,81	
UCFC207-20	1 1/4															24415	14630	UC207-20	FC207	1,87	
UCFC207-21	1 3/16	5 5/16	4 21/64	3 1/16	7/16	3 5/64	5/16	23/64	1 1/32	3,5433	1 1/16	1 1/8	1,6890	0,689	7/16	24415	14630	UC207-21	FC207	1,84	
UCFC207-22	1 3/8															24415	14630	UC207-22	FC207	1,81	
UCFC207-23	1 7/16															24415	14630	UC207-23	FC207	1,78	
UCFC208	40	145	120	84,8	11	14	10	9	26	100	41,2	45,5	49,2	19	M12	27645	16910	UC208	FC208	2,14	
UCFC208-24	1 1/2	5 45/64	4 27/32	3 11/32	7/16	3 5/64	2 5/64	23/64	1 1/32	3,9370	1 1/8	1 1/64	1,9370	0,748	7/16	27645	16910	UC208-24	FC208	2,18	
UCFC208-25	1 5/8															27645	16910	UC208-25	FC208	2,15	
UCFC209	45	160	132	93,3	10	16	12	14	26	105	40,2	44,5	49,2	19	M14	32395	20235	UC209	FC209	2,68	
UCFC209-26	1 5/8															32395	20235	UC209-26	FC209	2,78	
UCFC209-27	1 11/16	6 19/64	5 13/64	3 43/64	25/64	5/8	1 5/32	3 5/64	1 1/32	4,1339	1 37/64	1 3/4	1,9370	0,748	1/2	32395	20235	UC209-27	FC209	2,74	
UCFC209-28	1 3/4															32395	20235	UC209-28	FC209	2,70	
UCFC210	50	165	138	97,6	10	16	12	14	28	110	42,6	47,5	51,6	19	M14	33345	22135	UC210	FC210	2,90	
UCFC210-29	1 3/16															33345	22135	UC210-29	FC210	3,02	
UCFC210-30	1 7/8	6 1/2	5 7/16	3 27/32	25/64	5/8	1 5/32	3 5/64	1 7/64	4,3307	1 1/16	1 1/8	2,0315	0,748	1/2	33345	22135	UC210-30	FC210	2,97	
UCFC210-31	1 5/8															33345	22135	UC210-31	FC210	2,92	
UCFC210-32	2															33345	22135	UC210-32	FC210	2,88	
UCFC211	55	185	150	106,1	13	19	12	15	31	125	46,4	51	55,6	22,2	M16	41230	27930	UC211	FC211	4,01	
UCFC211-32	2															41230	27930	UC211-32	FC211	4,16	
UCFC211-33	2 1/16	7 9/32	5 29/32	4 3/16	3 3/64	3/4	1 5/32	1 9/32	1 7/32	4,9213	1 33/64	2 1/64	2,1890	0,874	5/8	41230	27930	UC211-33	FC211	4,10	
UCFC211-34	2 1/8															41230	27930	UC211-34	FC211	4,05	
UCFC211-35	2 3/16															41230	27930	UC211-35	FC211	3,99	
UCFC212	60	195	160	113,1	17	19	12	15	36	135	56,7	61,5	65,1	25,4	M16	49780	34390	UC212	FC212	4,94	
UCFC212-36	2 1/4															49780	34390	UC212-36	FC212	5,07	
UCFC212-37	2 5/16	7 11/16	6 19/64	4 29/64	4 3/64	3/4	1 5/32	1 9/32	1 27/64	5,3150	2 15/64	2 27/64	2,5630	1,000	5/8	49780	34390	UC212-37	FC212	4,99	
UCFC212-38	2 3/8															49780	34390	UC212-38	FC212	4,92	
UCFC212-39	2 7/16															49780	34390	UC212-39	FC212	4,85	
UCFC213	65	205	170	120,2	16	19	14	15	36	145	55,7	60,5	65,1	25,4	M16	54340	38095	UC213	FC213	5,65	
UCFC213-40	2 1/2	8 5/64	6 11/16	4 47/64	5/8	3/4	3 5/64	1 9/32	1 27/64	5,5118	1 3/16	2 23/64	2,5630	1,000	5/8	54340	38095	UC213-40	FC213	5,74	
UCFC213-41	2 5/8															54340	38095	UC213-41	FC213	5,65	
UCFC214	70	215	177	125,1	17	19	14	18	40	150	61,4	-	74,6	30,2	M16	59090	41895	UC214	FC214	6,95	
UCFC214-42	2 5/8															59090	41895	UC214-42	FC214	7,16	
UCFC214-43	2 11/16	8 15/32	6 31/32	4 59/64	4 3/64	3/4	3 5/64	2 3/32	1 37/64	5,9055	1 13/32	-	2,9370	1,189	5/8	59090	41895	UC214-43	FC214	7,06	
UCFC214-44	2 3/4															59090	41895	UC214-44	FC214	6,96	
UCFC215	75	220	184	130,1	18	19	16	18	40	160	62,5	-	77,8	33,3	M16	64030	45885	UC215	FC215	7,56	
UCFC215-45	2 3/16															64030	45885	UC215-45	FC215	7,81	
UCFC215-46	2 7/8	8 31/32	7 1/4	5 1/8	2 3/32	3/4	5/8	2 3/32	1 37/64	6,2992	2 19/32	-	3,0630	1,311	5/8	64030	45885	UC215-46	FC215	7,70	
UCFC215-47	2 5/8															64030	45885	UC215-47	FC215	7,59	
UCFC215-48	3															64030	45885	UC215-48	FC215	7,47	
UCFC216	80	240	200	141,4	18	23	16	18	42	170	67,3	-	82,6	33,3	M20	69065	50350	UC216	FC216	9,15	
UCFC216-49	3 1/16															69065	50350	UC216-49	FC216	9,28	
UCFC216-50	3 1/8	9 29/64	7 7/8	5 5/16	2 3/32	2 9/32	5/8	2 3/32	1 21/32	6,6929	2 21/32	-	3,2520	1,311	3/4	69065	50350	UC216-50	FC216	9,20	
UCFC216-51	3 3/16															69065	50350	UC216-51	FC216	9,07	
UCFC217	85	250	208	147,1	18	23	18	20	45	180	69,6	-	85,7	34,1	M20	79800	58805	UC217	FC217	10,81	
UCFC217-52	3 3/4															79800	58805	UC217-52	FC217	11,03	
UCFC217-53	3 5/8	9 27/32	8 3/16	5 31/64	2 3/32	2 9/32	2 3/32	2 5/32	1 25/32	7,0866	2 3/4	-	3,3740	1,343	3/4	79800	58805	UC217-53	FC217	10,89	
UCFC217-55	3 7/8															79800	58805	UC217-55	FC217	10,60	
UCFC218	90	265	220	155,5	22	23	18	20	50	190	78,3	-	96	39,7	M20	91295	67925	UC218	FC218	12,96	
UCFC218-56	3 1/2	10 7/16	8 21/32	6 1/8	5 5/64	2 9/32	2 3/32														

HCFC2 Serie normale - Standard duty

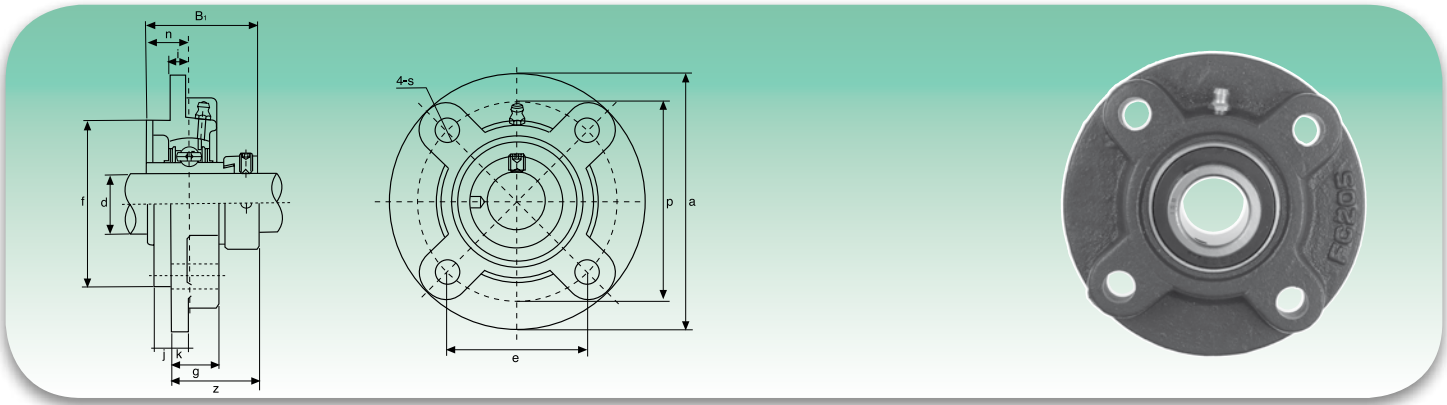

Tipo Type	Dimensioni - Dimensions													Bull. fiss. Bolt Size	Coefficients di carico (N) Load ratings (N)		Cuscinetto Bearing	Supporto Housing	Peso Weight
	d	a	p	e	i	s	j	k	g	f	z	B ₁	n		Dinamico C Dynamic C	Statico C ₀ Static C ₀			
	mm/inch														mm/inch				
HCFC204	12	100	78	55,1	10	12	5	7	20,5	62	36,6	43,7	17,1	M10	12160	6318	HC204	FC204	0,76
HCFC204-12	3/4	3 15/16	3 5/8	2 1/4	25/64	15/32	13/64	9/32	13/16	2,4409	1 1/16	1,720	0,673	3/8			HC204-12		0,76
HCFC205	25	115	90	63,6	10	12	6	7	21	70	36,9	44,4	17,5	M10	13300	7457	HC205	FC205	1,07
HCFC205-13	1 13/16																HC205-13		1,12
HCFC205-14	7/8																HC205-14		1,11
HCFC205-15	15/16	4 17/32	3 35/64	2 1/2	25/64	15/32	15/64	9/32	53/64	2,7559	1 29/64	1,748	0,689	3/8			HC205-15		1,09
HCFC205-16	1																HC205-16		1,07
HCFC206	30	125	100	70,7	10	12	8	8	23	80	40,1	48,4	18,3	M10	18525	10735	HC206	FC206	1,43
HCFC206-17	1 1/16																HC206-17		1,48
HCFC206-18	1 1/8	4 39/64	3 15/16	2 25/32	25/64	15/32	5/16	5/16	29/32	3,1496	1 37/64	1,906	0,720	3/8			HC206-18		1,45
HCFC206-19	1 3/16																HC206-19		1,43
HCFC206-20	1 1/4																HC206-20		1,40
HCFC207	35	135	110	77,8	11	14	8	9	26	90	43,3	51,1	18,8	M12	24415	14630	HC207	FC207	1,93
HCFC207-20	1 1/4																HC207-20		2,00
HCFC207-21	1 5/16	1 5/16	4 21/64	3 1/16	7/16	35/64	5/16	23/64	1 1/32	3,5433	1 45/64	2,012	0,740	7/16			HC207-21		1,96
HCFC207-22	1 3/8																HC207-22		1,93
HCFC207-23	1 7/16																HC207-23		1,87
HCFC208	40	145	120	84,8	11	14	10	9	26	100	45,9	56,3	21,4	M12	27645	16910	HC208	FC208	2,29
HCFC208-24	1 1/2	5 45/64	4 23/32	3 11/32	7/16	35/64	25/64	23/64	1 1/32	3,9370	1 13/16	2,217	0,843	7/16			HC208-24		2,34
HCFC208-25	1 9/16																HC208-25		2,30
HCFC209	45	160	132	93,3	10	16	12	14	26	105	44,9	56,3	21,4	M14	32395	20235	HCF209	FC209	2,85
HCFC209-26	1 5/8																HC209-26		2,96
HCFC209-27	1 11/16	6 19/64	5 13/64	3 43/64	25/64	5/8	15/32	35/64	1 1/32	4,1339	1 49/64	2,217	0,843	1/2			HC209-27		2,91
HCFC209-28	1 3/4																HC209-28		2,87
HCFC210	50	165	138	97,6	10	16	12	14	28	110	48,1	62,7	24,6	M14	33345	22135	HCF210	FC210	3,09
HCFC210-29	1 13/16																HC210-29		3,24
HCFC210-30	1 7/8	6 1/2	5 7/16	3 27/32	25/64	5/8	15/32	35/64	1 7/64	4,3307	1 57/64	2,469	0,969	1/2			HC210-30		3,18
HCFC210-31	1 15/16																HC210-31		3,12
HCFC210-32	2																HC210-32		3,06
HCFC211	55	185	150	106,1	13	19	12	15	31	125	56,6	71,4	27,8	M16	41230	27930	HCF211	FC211	4,22
HCFC211-32	2																HC211-32		4,42
HCFC211-33	2 3/16	7 9/32	5 29/32	4 3/16	33/64	3/4	15/32	19/32	1 7/32	4,9213	2 15/64	2,811	1,094	5/8			HC211-33		4,34
HCFC211-34	2 1/8																HC211-34		4,27
HCFC211-35	2 3/16																HC211-35		4,19
HCFC212	60	195	160	113,1	17	19	12	15	36	135	63,8	77,8	31	M16	49780	34390	HC212	FC212	5,28
HCFC212-36	2 1/4																HC212-36		5,44
HCFC212-37	2 5/16	7 11/16	6 19/64	4 29/64	43/64	3/4	15/32	19/32	1 27/64	5,3150	2 33/64	3,063	1,220	5/8			HC212-37		5,35
HCFC212-38	2 3/8																HC212-38		5,30
HCFC212-39	2 7/16																HC212-39		5,17
HCFC213	65	205	170	120,2	16	19	14	15	36	145	67,6	85,7	34,1	M16	54340	38095	HC213	FC213	6,21
HCFC213-40	2 1/2	8 5/64	6 11/16	4 47/64	5/8	3/4	35/64	19/32	1 27/64	5,5118	2 21/32	3,374	1,343	5/8			HC213-40		6,31
HCFC213-41	2 9/16																HC213-41		6,20
HCFC214	70	215	177	125,1	17	19	14	18	40	150	68,6	85,7	34,1	M16	59090	41895	HC214	FC214	7,45
HCFC214-42	2 3/8																HC214-42		7,69
HCFC214-43	2 11/16	8 15/32	6 31/32	4 59/64	43/64	3/4	35/64	23/32	1 37/64	5,9055	2 45/64	3,374	1,343	5/8			HC214-43		7,58
HCFC214-44	2 3/4																HC214-44		7,46
HCFC215	75	220	184	130,1	18	19	16	18	40	160	72,8	92,1	37,3	M16	64030	45885	HC215	FC215	8,19
HCFC215-45	2 13/16																HC215-45		8,49
HCFC215-46	2 7/8	8 21/32	7 1/4	5 1/8	23/32	3/4	5/8	23/32	1 37/64	6,2992	2 7/8	3,626	1,469	5/8			HC215-46		8,36
HCFC215-47	2 15/16																HC215-47		8,23
HCFC215-48	3																HC215-48		8,09

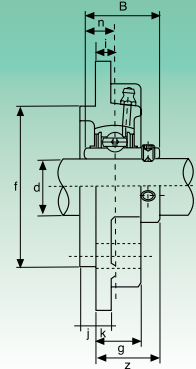
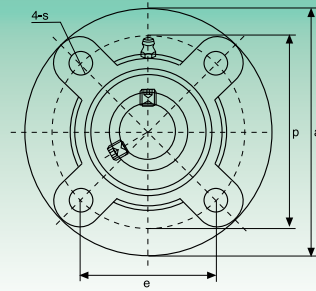
UCFCX Serie media - Medium duty

Tipo Type	Dimensioni - Dimensions													Bull. fiss. Bolt Size	Coefficienti di carico (N) Load ratings (N)		Cuscinetto Bearing	Supporto Housing	Peso Weight	
	d	a	p	e	i	s	j	k	g	f	z	B	n		Dinamico C Dynamic C	Statico C ₀ Static C ₀				kg
	mm/inch														mm/inch					
UCFCX05 UCFCX05-13 UCFCX05-14 UCFCX05-15 UCFCX05-16	25 1 3/16 7/8 1 5/16 1	111 4 3/8	92 3 3/8	65 2 5/8	10 2 5/8	9,5 3/8	6 1 5/8	9,5 3/8	24 1 5/8	76 2,9921	32,2 1 1/32	38,1 1,5000	15,9 0,626	M8 5/16	18525	10735	UCX05 UCX05-13 UCX05-14 UCX05-15 UCX05-16	FCX05	1,2	
UCFCX06 UCFCX06-17 UCFCX06-18 UCFCX06-19 UCFCX06-20	30 1 1/8 1 1/8 1 3/8 1 1/4	127 5	105 4 1/4	74,2 2 9/16	8 5/16	12 1 1/2	9,5 3/8	9,5 3/8	22,5 7/8	85 3,3465	33,4 1 1/16	42,9 1,6890	17,5 0,689	M10 3/8	24415	14630	UCX06 UCX06-17 UCX06-18 UCX06-19 UCX06-20	FCX06	1,5	
UCFCX07 UCFCX07-21 UCFCX07-22 UCFCX07-23	35 1 3/8 1 3/8 1 7/8	133 5 1/4	111 4 3/8	78,5 3 1/2	9 2 3/4	12 1 1/2	11 7/16	11 7/16	26 1 1/2	92 3,6220	39,2 1 1/32	49,2 1,9370	19 0,748	M10 3/8	27645	16910	UCX07 UCX07-21 UCX07-22 UCX07-23	FCX07	1,9	
UCFCX08 UCFCX08-24 UCFCX08-25	40 1 1/2 1 1/2	133 5 1/4	111 4 3/8	78,5 3 1/2	9 2 3/4	12 1 1/2	11 7/16	11 7/16	26 1 1/2	92 3,6220	39,2 1 1/32	49,2 1,9370	19 0,748	M10 3/8	32395	20235	UCX08 UCX08-24 UCX08-25	FCX08	2,0	
UCFCX09 UCFCX09-26 UCFCX09-27 UCFCX09-28 UCFCX09-29	45 1 7/8 1 7/8 1 3/4 1 3/4	155 6 1/2	130 5 1/8	91,9 3 5/8	8 5/16	14 3 5/8	12 1 1/2	11 7/16	25 6 3/4	108 4,2520	40,6 1 1/32	51,6 2,0315	19 0,748	M12 7/16	33345	22135	UCX09 UCX09-26 UCX09-27 UCX09-28 UCX09-29	FCX09	2,6	
UCFCX10 UCFCX10-30 UCFCX10-31 UCFCX10-32	50 1 7/8 1 13/16 2	162 6 3/8	136 5 23/64	96,2 3 25/32	7 9/32	14 3 5/8	16 5/8	11 7/16	25 6 3/4	118 4,6457	40,4 1 1/32	55,6 2,1890	22,2 0,874	M12 7/16	41230	27930	UCX10 UCX10-30 UCX10-31 UCX10-32	FCX10	3,2	
UCFCX11 UCFCX11-33 UCFCX11-34 UCFCX11-35 UCFCX11-36 UCFCX11-37	55 2 1/8 2 1/8 2 3/8 2 1/4 2 3/8	180 7 1/2	152 5 63/64	107,5 4 15/64	4 5/32	16 5/8	22 5 5/8	13 1/2	26 1 1/2	127 5,0000	43,7 1 23/32	65,1 2,5630	25,4 1,000	M14 1/2	49780	34390	UCX11 UCX11-33 UCX11-34 UCX11-35 UCX11-36 UCX11-37	FCX11	4,3	
UCFCX12 UCFCX12-38 UCFCX12-39	60 2 3/8 2 7/16	194 7 7/8	165 6 1/2	116,7 4 19/32	11 7/16	16 5/8	20 2 5/32	14 9/16	33 1 1/16	140 5,5118	50,7 2	65,1 2,5630	25,4 1,000	M14 1/2	54340	38095	UCX12 UCX12-38 UCX12-39	FCX12	5,3	
UCFCX13 UCFCX13-40 UCFCX13-41	65 2 1/2 2 9/16	194 7 7/8	165 6 1/2	116,7 4 19/32	11 7/16	16 5/8	20 2 5/32	14 9/16	33 1 1/16	140 5,5118	55,4 2 1/16	74,6 2,9370	30,2 1,189	M14 1/2	59090	41895	UCX13 UCX13-40 UCX13-41	FCX13	5,7	
UCFCX14 UCFCX14-42 UCFCX14-43 UCFCX14-44	70 2 3/8 2 1/16 2 3/4	222 8 3/4	190 7 3/8	134,3 5 1/2	14 3 5/8	19 3/4	20 2 5/32	14 9/16	36 1 13/32	164 6,4567	58,5 2 1/8	77,8 3,0630	33,3 1,311	M16 5/8	64030	45885	UCX14 UCX14-42 UCX14-43 UCX14-44	FCX14	7,3	
UCFCX15 UCFCX15-45 UCFCX15-46 UCFCX15-47 UCFCX15-48	75 2 13/16 2 7/8 2 15/16 3	222 8 3/4	190 7 3/8	134,3 5 1/2	12 1 5/8	19 3/4	22 5 5/8	16 5/8	35 1 3/8	164 6,4567	61,3 2 13/32	82,6 3,2520	33,3 1,311	M16 5/8	69065	50350	UCX15 UCX15-45 UCX15-46 UCX15-47 UCX15-48	FCX15	8	
UCFCX16 UCFCX16-49 UCFCX16-50 UCFCX16-51 UCFCX16-52	80 3 1/16 3 1/8 3 3/16 3 1/4	260 10 1/4	219 8 5/8	154,8 6 1/2	10 2 5/8	23 2 9/32	25 6 3/4	19 3/4	36 1 13/32	186 7,3228	61,6 2 1/8	85,7 3,3740	34,1 1,343	M20 3/4	79800	58805	UCX16 UCX16-49 UCX16-50 UCX16-51 UCX16-52	FCX16	11,3	
UCFCX17 UCFCX17-53 UCFCX17-55	85 3 3/16 3 7/16	260 10 1/4	219 8 5/8	154,8 6 1/2	10 2 5/8	23 2 9/32	25 6 3/4	19 3/4	36 1 13/32	186 7,3228	66,3 2 5/8	96 3,7795	39,7 1,5630	M20 3/4	91295	67925	UCX17 UCX17-53 UCX17-55	FCX17	12,9	
UCFCX18 UCFCX18-56 UCFCX18-57	90 3 7/16 3 1/2	260 10 1/4	219 8 5/8	154,8 6 1/2	12 1 5/8	23 2 9/32	28 1 7/8	19 -	43 1 11/16	186 7,3228	73,1 -	104 4,0945	42,9 1,689	M20 3/4	103550	77805	UCX18 UCX18-56 UCX18-57	FCX18	12	
UCFCX20 UCFCX20-58 UCFCX20-59 UCFCX20-60 UCFCX20-61	100 3 13/16 3 7/8 3 15/16 4	276 10 7/8	238 9 3/8	168,3 6 5/8	22 5 5/8	23 2 9/32	28 1 7/8	22 -	66 2 13/32	206 8,1102	90,3 -	117,5 4,6260	49,2 1,937	M20 3/4	126350	99750	UCX20 UCX20-58 UCX20-59 UCX20-60 UCX20-61	FCX20	16	

UKFC2 Serie normale - Standard duty

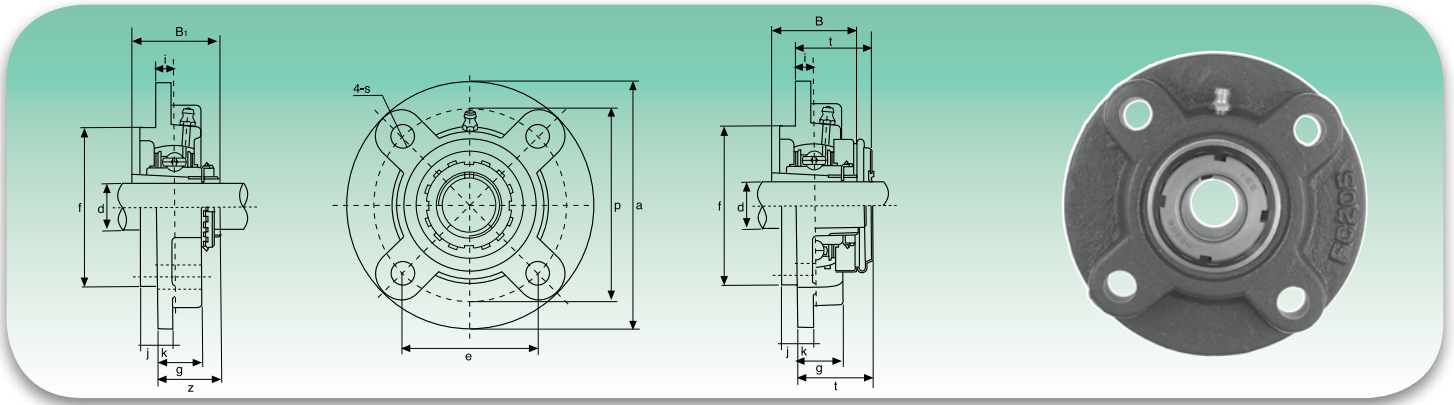

Tipo Type	Dimensioni - Dimensions														Bull. fiss. Bolt Size	Coefficients di carico (N) Load ratings (N)		Cuscinetto Bearing	Supporto Housing	Peso Weight
	d	a	p	e	i	s	j	k	g	f	z	t	B ₁	Dinamico C Dynamic C _d		Statico C ₀ Static C ₀	kg			
	mm/inch															mm/inch				
UKFC205+H2305	20	115	90	63,6	10	12	6	7	21	70	29,5	34	35	M10	13300	7457	UK205+H2305	FC205	1,05	
UKFC205+HE2305	3/4	4 17/32	3 35/64	2 1/2	1 5/64	1 1/32	1 5/64	9/32	5 3/64	2,7559	1 1/32	1 11/32	1,378	3/8			UK205+HE2305			
UKFC206+H2306	25	125	100	70,7	10	12	8	8	23	80	31	36,5	38	M10	18525	10735	UK206+H2306	FC206	1,34	
UKFC206+HS2306	7/8	4 59/64	3 15/16	2 25/32	2 5/64	1 1/32	5/16	5/16	2 29/32	3,1496	1 1/32	1 7/16	1,496	3/8			UK206+HS2306			
UKFC206+HE2306	1																UK206+HE2306			
UKFC207+H2307	30	135	110	77,8	11	14	8	9	26	90	33,5	41	43	M12	24415	14630	UK207+H2307	FC207	1,90	
UKFC207+HS2307	1 1/8	5 3/8	4 21/64	3 1/8	7/16	3 3/64	5/16	2 3/64	1 1/32	3,5433	1 1/16	1 1/8	1,693	7/16			UK207+HS2307			
UKFC208+H2308	35	145	120	84,8	11	14	10	9	26	100	35,5	45,5	46	M12	27645	16910	UK208+H2308	FC208	2,24	
UKFC208+HE2308	1 1/4																UK208+HE2308			
UKFC208+HS2308	1 3/8	5 49/64	4 23/32	3 11/32	7/16	3 3/64	2 5/64	2 3/64	1 1/32	3,9370	1 25/64	1 5/64	1,811	7/16			UK208+HS2308			
UKFC209+H2309	40	160	132	93,3	10	16	12	14	26	105	36	44,5	50	M14	32395	20235	UK209+H2309	PFC209	2,83	
UKFC209+HA2309	1 7/16																UK209+HA2309			
UKFC209+HE2309	1 1/2	6 1/64	5 13/64	3 43/64	2 5/64	5/8	1 1/32	3 3/64	1 1/32	4,1339	1 27/64	1 3/4	1,969	1/2			UK209+HE2309			
UKFC209+HS2309	1 5/8																UK209+HS2309			
UKFC210+H2310	45	165	138	97,6	10	16	12	14	28	110	37,5	47,5	55	M14	33345	22135	UK210+H2310	FC210	3,07	
UKFC210+HS2310	1 5/8																UK210+HS2310			
UKFC210+HA2310	1 11/16	6 1/2	5 7/16	3 27/32	2 5/64	5/8	1 1/32	3 3/64	1 1/64	4,3307	1 15/32	1 7/8	2,165	1/2			UK210+HA2310			
UKFC210+HE2310	1 3/4																UK210+HE2310			
UKFC211+H2311	50	185	150	106,1	13	19	12	15	31	125	41,5	51	59	M16	41230	27930	UK211+H2311	FC211	4,16	
UKFC211+HS2311	1 7/8																UK211+HS2311			
UKFC211+HA2311	1 15/16	7 3/32	5 29/32	4 3/16	3 3/64	3/4	1 1/32	1 19/32	1 1/32	4,9213	1 41/64	2 1/64	2,323	5/8			UK211+HA2311			
UKFC211+HE2311	2																UK211+HE2311			
UKFC212+H2312	55	195	160	113,1	17	19	12	15	36	135	48	61,5	62	M16	49780	34390	UK212+H2312	FC212	4,99	
UKFC212+HS2312	2 1/8	7 11/16	6 19/64	4 29/64	4 3/64	3/4	1 1/32	1 19/32	1 27/64	5,3150	1 57/64	2 27/64	2,441	5/8			UK212+HS2312			
UKFC213+H2313	60	205	170	120,2	16	19	14	15	36	145	49	60,5	65	M16	54340	38095	UK213+H2313	FC213	5,56	
UKFC213+HA2313	2 3/16																UK213+HA2313			
UKFC213+HE2313	2 1/4	8 5/64	6 11/16	4 47/64	5/8	3/4	3 3/64	1 19/32	1 27/64	5,5118	1 15/16	2 25/64	2,559	5/8			UK213+HE2313			
UKFC213+HS2313	2 3/8																UK213+HS2313			
UKFC215+H2315	65	220	184	130,1	18	19	16	18	40	160	53,5	-	73	M16	64030	45885	UK215+H2315	FC215	7,67	
UKFC215+HA2315	2 7/16																UK215+HA2315			
UKFC215+HE2315	2 1/2	8 1/32	7 1/4	5 1/8	2 3/32	3/4	5/8	2 3/32	1 37/64	6,2992	2 7/64	-	2,874	5/8			UK215+HE2315			
UKFC216+H2316	70	240	200	141,4	18	23	16	18	42	170	57	-	78	M20	69065	50350	UK216+H2316	FC216	9,41	
UKFC216+HA2316	2 11/16																UK216+HA2316			
UKFC216+HE2316	2 3/4	9 29/64	7 7/8	5 9/16	2 3/32	2 9/32	5/8	2 3/32	1 21/32	6,6929	2 1/4	-	3,071	3/4			UK216+HE2316			
UKFC217+H2317	75	250	208	147,1	18	23	18	20	45	180	59	-	82	M20	79800	58805	UK217+H2317	FC217	11,23	
UKFC217+HA2317	2 5/16																UK217+HA2317			
UKFC217+HE2317	3	9 27/32	8 3/16	5 51/64	2 3/32	2 9/32	2 3/32	2 5/32	1 25/32	7,0866	2 1/64	-	3,228	3/4			UK217+HE2317			
UKFC218+H2318	80	265	220	155,5	22	23	18	20	50	190	64,5	-	86	M20	91295	67925	UK218+H2318	FC218	13,34	
UKFC218+HA2318	3 3/16	10 7/16	8 21/32	6 1/8	5 5/64	2 9/32	2 3/32	2 5/32	1 31/32	7,4803	3 35/64	-	3,386	3/4			UK218+HA2318			

Bussole HA; HE; HS con filettatura in pollici
Inch dimension adapter sleeves HA; HE; HS

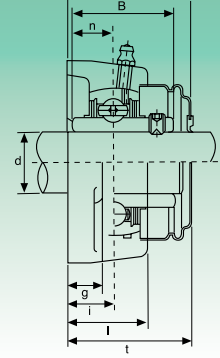
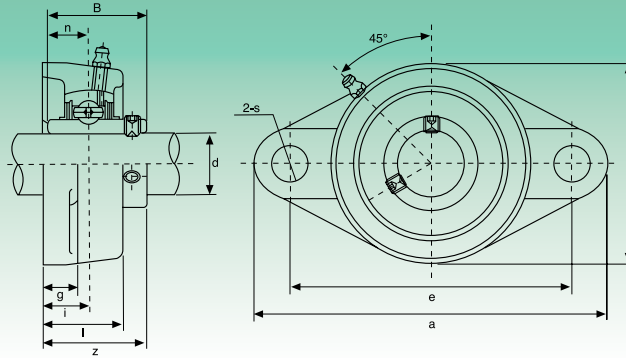

Tipo Type	Dimensioni - Dimensions												Bull. fiss. Bolt Size	Coefficients di carico (N) Load ratings (N)		Cuscinetto Bearing	Supporto Housing	Peso Weight
	d	a	e	i	g	l	s	b	z	t	B	n		Dinamico C Dynamic C	Statico C ₀ Static C ₀			
	mm/inch													mm/inch				
UCFL201 UCFL201-8	12 3/4	113 4 7/16	90 3 35/64	15 1 1/32	11 7/16	25,5 1	12 1 1/32	60 2 3/8	33,3 1 1/16	37,5 1 3/8	31 1,2205	12,7 0,500	M10 3/8	12160	6318	UC201 UC201-8	FL204	0,45 0,44
UCFL202 UCFL202-9 UCFL202-10	15 9/16 5/8	113 4 7/16	90 3 35/64	15 1 1/32	11 7/16	25,5 1	12 1 1/32	60 2 3/8	33,3 1 1/16	37,5 1 3/8	31 1,2205	12,7 0,500	M10 3/8	12160	6318	UC202 UC202-9 UC202-10	FL204	0,44 0,44 0,44
UCFL203 UCFL203-11	17 1 1/16	113 4 7/16	90 3 35/64	15 1 1/32	11 7/16	25,5 1	12 1 1/32	60 2 3/8	33,3 1 1/16	37,5 1 3/8	31 1,2205	12,7 0,500	M10 3/8	12160	6318	UC203 UC203-11	FL204	0,43 0,42
UCFL204 UCFL204-12	20 3/4	113 4 7/16	90 3 35/64	15 1 1/32	11 7/16	25,5 1	12 1 1/32	60 2 3/8	33,3 1 1/16	37,5 1 3/8	31 1,2205	12,7 0,500	M10 3/8	12160	6318	UC204 UC204-12	FL204	0,41 0,41
UCFL205 UCFL205-13 UCFL205-14 UCFL205-15 UCFL205-16	25 1 3/16 7/8 1 1/16 1	130 5 1/8	99 3 5/8	16 5/8	13 1/2	27 1 1/16	16 3/8	68 2 1/16	35,8 1 1/32	40 1 1/8	34,1 1,3425	14,3 0,563	M14 1/2	13300	7457	UC205 UC205-13 UC205-14 UC205-15 UC205-16	FL205	0,58 0,62 0,61 0,59 0,58
UCFL206 UCFL206-17 UCFL206-18 UCFL206-19 UCFL206-20	30 1 1/16 1 1/8 1 3/16 1 1/4	148 5 13/16	117 4 3/8	18 4 5/16	13 1/2	31 1 1/32	16 5/8	80 3 1/2	40,2 1 1/32	44,5 1 3/4	38,1 1,5000	15,9 0,626	M14 1/2	18525	10735	UC206 UC206-17 UC206-18 UC206-19 UC206-20	FL206	0,86 0,89 0,88 0,86 0,85
UCFL207 UCFL207-20 UCFL207-21 UCFL207-22 UCFL207-23	35 1 1/4 1 5/16 1 3/8 1 7/16	161 6 1/32	130 5 1/8	19 3/4	14 3 5/16	34 1 1/32	16 5/8	90 3 3/8	44,4 1 3/4	48,5 1 29/32	42,9 1,6890	17,5 0,689	M14 1/2	24415	14630	UC207 UC207-20 UC207-21 UC207-22 UC207-23	FL207	1,08 1,14 1,11 1,08 1,05
UCFL208 UCFL208-24 UCFL208-25	40 1 1/2 1 1/16	175 6 7/8	144 5 43/64	21 53/64	14 3 5/16	36 1 1/32	16 5/8	100 3 15/16	51,2 2 1/16	55,5 2 1/8	49,2 1,9370	19 0,748	M14 1/2	27645	16910	UC208 UC208-24 UC208-25	FL208	1,44 1,48 1,45
UCFL209 UCFL209-26 UCFL209-27 UCFL209-28	45 1 3/8 1 11/16 1 3/4	188 7 1/32	148 5 53/64	22 5 5/16	15 1 1/32	38 1 1/2	19 3/4	108 4 1/4	52,2 2 1/16	56,5 2 1/8	49,2 1,9370	19 0,748	M16 5/8	32395	20235	UC209 UC209-26 UC209-27 UC209-28	FL209	1,74 1,84 1,80 1,76
UCFL210 UCFL210-29 UCFL210-30 UCFL210-31 UCFL210-32	50 1 13/16 1 7/8 1 15/16 2	197 7 3/4	157 6 3/16	22 5 5/16	15 1 1/32	40 1 37/64	19 3/4	115 4 17/32	54,6 2 1/8	59,5 2 1/16	51,6 2,0315	19 0,748	M16 5/8	33345	22135	UC210 UC210-29 UC210-30 UC210-31 UC210-32	FL210	2,10 2,22 2,17 2,12 2,08
UCFL211 UCFL211-32 UCFL211-33 UCFL211-34 UCFL211-35	55 2 2 1/16 2 1/8 2 3/16	224 8 13/16	184 7 1/4	25 6 3/16	18 2 3/32	43 1 11/16	19 3/4	130 5 1/8	58,4 2 1/8	63 2 1/2	55,6 2,1890	22,2 0,874	M16 5/8	41230	27930	UC211 UC211-32 UC211-33 UC211-34 UC211-35	FL211	2,91 3,06 3,00 2,95 2,89
UCFL212 UCFL212-36 UCFL212-37 UCFL212-38 UCFL212-39	60 2 1/4 2 5/16 2 3/8 2 7/16	250 9 27/32	202 7 61/64	29 1 9/16	18 2 3/32	48 1 7/8	23 2 9/32	140 5 1/2	68,7 2 23/32	73,5 2 57/64	65,1 2,5630	25,4 1,000	M20 3/4	49780	34390	UC212 UC212-36 UC212-37 UC212-38 UC212-39	FL212	3,74 3,87 3,79 3,72 3,65
UCFL213 UCFL213-40 UCFL213-41	65 2 1/2 2 9/16	258 10 5/32	210 8 17/64	30 1 1/16	22 7/8	50 1 1/32	23 2 9/32	155 6 3/32	69,7 2 3/4	74,5 2 15/16	65,1 2,5630	25,4 1,000	M20 3/4	54340	38095	UC213 UC213-40 UC213-41	FL213	4,57 4,66 4,57
UCFL214 UCFL214-42 UCFL214-43 UCFL214-44	70 2 5/8 2 11/16 2 3/4	265 10 7/16	216 8 1/2	31 1 7/32	22 7/8	54 2 1/8	23 2 9/32	160 6 5/16	75,4 2 3/32	- 2,9370	74,6 1,189	30,2 1,189	M20 3/4	59090	41895	UC214 UC214-42 UC214-43 UC214-44	FL214	5,11 5,32 5,22 5,12
UCFL215 UCFL215-45 UCFL215-46 UCFL215-47 UCFL215-48	75 2 13/16 2 7/8 2 15/16 3	275 10 13/16	225 8 55/64	34 1 11/32	22 7/8	56 2 1/32	23 2 9/32	165 6 1/2	78,5 3 3/32	- 3,0630	77,8 1,311	33,3 1,311	M20 3/4	64030	45885	UC215 UC215-45 UC215-46 UC215-47 UC215-48	FL215	5,37 5,62 5,51 5,40 5,28
UCFL216 UCFL216-49 UCFL216-50 UCFL216-51	80 3 1/16 3 3/8 3 1/2	290 11 13/32	233 9 11/64	34 1 11/32	22 7/8	58 2 9/32	25 2 3/32	180 7 3/32	83,3 3 3/32	- 3,2520	82,6 1,311	33,3 1,311	M22 7/8	69065	50350	UC216 UC216-49 UC216-50 UC216-51	FL216	7,20 7,38 7,25 7,12
UCFL217 UCFL217-52 UCFL217-53 UCFL217-55	85 3 3/4 3 3/8 3 3/16	305 12	248 9 9/64	36 1 27/64	24 1 1/16	63 2 1/32	25 2 3/32	190 7 1/32	87,6 3 1/16	- 3,3740	85,7 1,343	34,1 1,343	M22 7/8	79800	58805	UC217 UC217-52 UC217-53 UC217-55	FL217	8,61 8,83 8,69 8,40
UCFL218 UCFL218-56	90 3 1/2	320 12 19/32	265 10 7/16	40 1 37/64	24 1 5/16	68 2 11/16	25 2 1/16	205 8 1/16	96,3 3 29/32	- 3,7795	96 1,5630	39,7 1,5630	M22 7/8	91295	67925	UC218 UC218-56	FL218	10,51 10,62

Disponibile in acciaio inox Supporto: AISI 304 - Cuscinetto: AISI 440C o 420C - Available stainless steel Housing: AISI 304 - Bearing: AISI 440C or 420C
Disponibile su richiesta con cuscinetto SA (SAFL) - Available under request with SA bearing (SAFL)

HCFL2 Serie normale - Standard duty

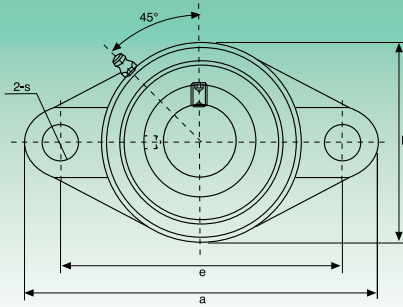
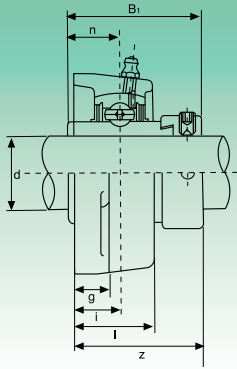

Tipo Type	Dimensioni - Dimensions											Bull. fiss. Bolt Size	Coefficienti di carico (N) Load ratings (N)		Cuscinetto Bearing	Supporto Housing	Peso Weight	
	d	a	e	i	g	l	s	b	z	B ₁	n		Dinamico C Dynamic C	Statico C ₀ Static C ₀				kg
	mm/inch												mm/inch					
HCFL204	20	113	90	15	11	25,5	12	60	41,6	43,7	17,1	M10	12160	6318	HC204	FL204	0,48	
HCFL204-12	¾	4 7/16	3 3/8	1 9/32	7/16	1	1 15/32	2 3/8	1 4/64	1,720	0,673	¾						0,48
HCFL205	25	130	99	16	13	27	16	68	42,9	44,4	17,5	M14	13300	7457	HC205	FL205	0,65	
HCFL205-13	1 13/16																	0,70
HCFL205-14	7/8	5 1/8	3 5/8	5/8	1/2	1 1/16	5/8	2 1/16	1 1/16	1,748	0,689	1/2						0,69
HCFL205-15	1 1/16																	0,67
HCFL205-16	1																	0,65
HCFL206	30	148	117	18	13	31	16	80	48,1	48,4	18,3	M14			18525		10735	HC206
HCFL206-17	1 1/16															1,04		
HCFL206-18	1 1/8	5 13/16	4 3/8	4 5/8	1/2	1 7/32	5/8	3 5/32	1 5/16	1,906	0,720	1/2				1,01		
HCFL206-19	1 3/16															0,99		
HCFL206-20	1 1/4															0,96		
HCFL207	35	161	130	19	14	34	16	90	51,3	51,1	18,8	M14	24415	14630	HC207	FL207	1,20	
HCFL207-20	1 1/4																	1,27
HCFL207-21	1 3/16	6 1/32	5 1/8	3/4	3 5/8	1 11/32	5/8	3 35/64	2 1/4	2,012	0,740	1/2						1,23
HCFL207-22	1 3/8																	1,20
HCFL207-23	1 7/16																	1,17
HCFL208	40	175	144	21	14	36	16	100	55,9	56,3	21,4	M14	27645	16910	HC208	FL208	1,59	
HCFL208-24	1 1/2	6 7/8	5 3/4	5 3/8	3 5/8	1 13/32	5/8	3 13/16	2 3/8	2,217	0,843	1/2						1,64
HCFL208-25	1 1/16																	1,60
HCFL209	45	188	148	22	15	38	19	108	56,9	56,3	21,4	M14	32395	20235	HCF209	FL209	1,91	
HCFL209-26	1 5/8																	2,02
HCFL209-27	1 11/16	7 13/32	5 3/8	5 5/8	1 9/32	1 1/2	3/4	4 1/4	2 1/8	2,217	0,843	1/2						1,97
HCFL209-28	1 3/4																	1,93
HCFL210	50	197	157	22	15	40	19	115	60,1	62,7	24,6	M16	33345	22135	HCF210	FL210	2,29	
HCFL210-29	1 13/16																	2,44
HCFL210-30	1 7/8	7 3/4	6 1/16	5 5/8	1 9/32	1 37/64	3/4	4 17/32	2 23/64	2,469	0,969	5/8						2,38
HCFL210-31	1 15/16																	2,32
HCFL210-32	2														2,26			
HCFL211	55	224	184	25	18	43	19	130	68,6	71,4	27,8	M16	41230	27930	HCF211	FL211	3,12	
HCFL211-32	2																	3,32
HCFL211-33	2 3/16	8 13/16	7 1/4	6 3/8	2 3/32	1 11/16	3/4	5 1/8	2 4/8	2,811	1,094	5/8						3,24
HCFL211-34	2 1/8																	3,17
HCFL211-35	2 3/16																	3,09
HCFL212	60	250	202	29	18	48	23	140	75,8	77,8	31	M20	49780	34390	HC212	FL212	4,08	
HCFL212-36	2 1/4																	4,24
HCFL212-37	2 5/16	9 27/32	7 9/16	1 1/4	2 3/32	1 7/8	2 9/32	5 1/2	2 53/64	3,063	1,220	3/4						4,15
HCFL212-38	2 3/8																	4,10
HCFL212-39	2 7/16																	3,97
HCFL213	65	258	210	30	22	50	23	155	81,6	85,7	34,1	M20	54340	38095	HC213	FL213	5,13	
HCFL213-40	2 1/2	10 5/32	8 1/8	1 3/16	7/8	1 31/32	2 9/32	6 3/32	3 3/32	3,374	1,343	3/4						5,23
HCFL213-41	2 9/16																	5,12
HCFL214	70	265	216	31	22	54	23	160	82,6	85,7	34,1	M20	59090	41895	HC214	FL214	5,61	
HCFL214-42	2 3/8																	5,85
HCFL214-43	2 11/16	10 7/16	8 1/2	1 7/32	7/8	2 1/8	2 9/32	6 5/16	3 1/4	3,374	1,343	3/4						5,74
HCFL214-44	2 3/4																	5,62
HCFL215	75	275	225	34	22	56	23	165	88,8	92,1	37,3	M20	64030	45885	HC215	FL215	6,00	
HCFL215-45	2 13/16																	6,30
HCFL215-46	2 7/8	10 13/16	8 5/8	1 11/32	7/8	2 7/32	2 9/32	6 1/2	3 1/2	3,626	1,426	3/4						6,17
HCFL215-47	2 15/16																	6,04
HCFL215-48	3																	5,90

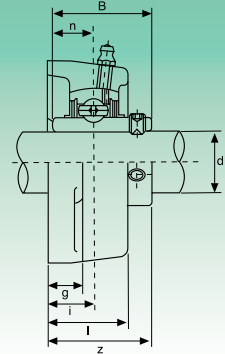
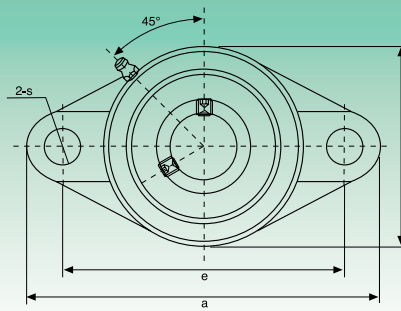

Tipo Type	Dimensioni - Dimensions											Bull. fiss. Bolt Size	Coefficients di carico (N) Load ratings (N)		Cuscinetto Bearing	Supporto Housing	Peso Weight kg
	d	a	e	i	g	l	s	b	z	B	n		Dinamico C Dynamic C	Statico C ₀ Static C ₀			
	mm/inch												mm/inch				
UCFL305 UCFL305-13 UCFL305-14 UCFL305-15 UCFL305-16	25 1 ¹³ / ₁₆	150	113	16	13	29	19	80	39	38	15	M16			UC305 UC305-13 UC305-14 UC305-15 UC305-16	FL305	1,1
UCFL306 UCFL306-17 UCFL306-18 UCFL306-19	30 1 ¹ / ₁₆	180	134	18	15	32	23	90	44	43	17	M20			UC306 UC306-17 UC306-18 UC306-19	FL306	1,5
UCFL307 UCFL307-20 UCFL307-21 UCFL307-22 UCFL307-23	35 1 ¹ / ₄	185	141	20	16	36	23	100	49	48	19	M20			UC307 UC307-20 UC307-21 UC307-22 UC307-23	FL307	1,9
UCFL308 UCFL308-24 UCFL308-25	40 1 ¹ / ₂	200	158	23	17	40	23	112	56	52	19	M20			UC308 UC308-24 UC308-25	FL308	2,5
UCFL309 UCFL309-26 UCFL309-27 UCFL309-28	45 1 ⁵ / ₁₆	230	177	25	18	44	25	125	60	57	22	M22			UC309 UC309-26 UC309-27 UC309-28	FL309	3,4
UCFL310 UCFL310-29 UCFL310-30 UCFL310-31	50 1 ³ / ₁₆	240	187	28	19	48	25	140	67	61	22	M22			UC310 UC310-29 UC310-30 UC310-31	FL310	4,4
UCFL311 UCFL311-32 UCFL311-33 UCFL311-34 UCFL311-35	55 2	250	198	30	20	52	25	150	71	66	25	M22			UC311 UC311-32 UC311-33 UC311-34 UC311-35	FL311	5,1
UCFL312 UCFL312-36 UCFL312-37 UCFL312-38 UCFL312-39	60 2 ¹ / ₄	270	212	33	22	56	31	160	78	71	26	M27			UC312 UC312-36 UC312-37 UC312-38 UC312-39	FL312	6,1
UCFL313 UCFL313-40 UCFL313-41	65 2 ¹ / ₂	295	240	33	25	58	31	175	78	75	30	M27			UC313 UC313-40 UC313-41	FL313	7,8
UCFL314 UCFL314-42 UCFL314-43 UCFL314-44	70 2 ⁵ / ₁₆	315	250	36	28	61	35	185	81	78	33	M30			UC314 UC314-42 UC314-43 UC314-44	FL314	9,0
UCFL315 UCFL315-45 UCFL315-46 UCFL315-47 UCFL315-48	75 2 ¹ / ₁₆	320	260	39	30	66	35	195	89	82	32	M30			UC315 UC315-45 UC315-46 UC315-47 UC315-48	FL315	10
UCFL316 UCFL316-49 UCFL316-50 UCFL316-51	80 3 ¹ / ₁₆	355	285	38	32	68	38	210	90	86	34	M33			UC316 UC316-49 UC316-50 UC316-51	FL316	13
UCFL317 UCFL317-52 UCFL317-53 UCFL317-55	85 3 ¹ / ₄	370	300	44	32	74	38	220	100	96	40	M33			UC317 UC317-52 UC317-53 UC317-55	FL317	15
UCFL318 UCFL318-55 UCFL318-56	90 3 ³ / ₁₆	385	315	44	36	76	38	235	100	96	40	M33			UC318 UC318-55 UC318-56	FL318	18
UCFL319 UCFL319-58 UCFL319-59 UCFL319-60	95 3 ⁵ / ₁₆	405	330	59	40	94	41	250	121	103	41	M36			UC319 UC319-58 UC319-59 UC319-60	FL319	22
UCFL320 UCFL320-61 UCFL320-62 UCFL320-63 UCFL320-64	100 3 ¹³ / ₁₆	440	360	59	40	94	44	270	125	108	42	M39			UC320 UC320-61 UC320-62 UC320-63 UC320-64	FL320	27
UCFL322 -	110 18 ¹ / ₂	470	390	60	42	96	44	300	131	117	46	M39			UC322	FL322	33
UCFL324 -	120 20 ¹ / ₂	520	430	65	48	110	47	330	140	126	51	M42			UC324	FL324	48
UCFL326 -	130 21 ¹ / ₂	550	460	65	50	115	47	360	146	135	54	M42			UC326	FL326	58
UCFL328 -	140 23 ³ / ₈	600	500	75	60	125	51	400	161	145	59	M45			UC328	FL328	81

UCFLX Serie media - Medium duty

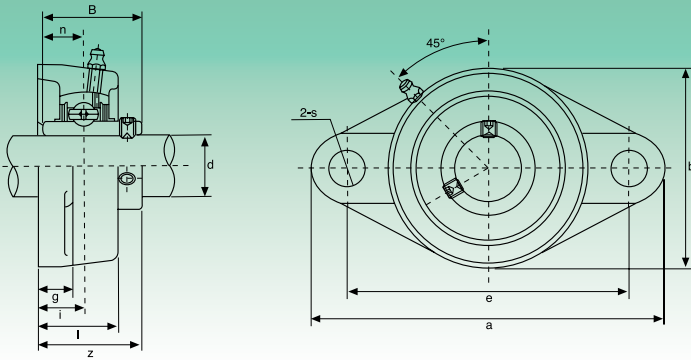

Tipo Type	Dimensioni - Dimensions											Bull. fiss. Bolt Size	Coefficients di carico (N) Load ratings (N)		Cuscinetto Bearing	Supporto Housing	Peso Weight kg
	d	a	e	i	g	l	s	b	z	B	n		Dinamico C Dynamic C	Statico C ₀ Static C ₀			
	mm/inch												mm/inch				
UCFLX05	25	141	117	18	13	30	12	83	40,2	38,1	15,9	M10			UCX05		
UCFLX05-13	1 ³ / ₁₆														UCX05-13		
UCFLX05-14	7 ⁸ / ₁₆														UCX05-14	FLX05	1,0
UCFLX05-15	1 ⁵ / ₁₆	5 ⁹ / ₁₆	4 ³ / ₁₆	4 ⁵ / ₁₆	1 ¹ / ₂	1 ³ / ₁₆	1 ⁵ / ₁₆	3 ⁹ / ₁₆	1 ³⁷ / ₆₄	1,5000	0,626	3 ⁸ / ₁₆	18525	10735	UCX05-15		
UCFLX05-16	1														UCX05-16		
UCFLX06	30	156	130	19	15	34	16	95	44,4	42,9	17,5	M14			UCX06		
UCFLX06-17	1 ¹ / ₁₆														UCX06-17		
UCFLX06-18	1 ¹ / ₈														UCX06-18	FLX06	1,5
UCFLX06-19	1 ³ / ₁₆	6 ⁵ / ₁₆	5 ¹ / ₈	3 ⁴ / ₁₆	1 ⁹ / ₁₆	1 ¹¹ / ₁₆	5 ⁸ / ₁₆	3 ³ / ₄	1 ³ / ₄	1,6890	0,689	1 ¹ / ₂	24415	14630	UCX06-19		
UCFLX06-20	1 ¹ / ₄														UCX06-20		
UCFLX07	35	171	144	21	16	38	16	105	51,2	49,2	19	M14			UCX07		
UCFLX07-21	1 ⁵ / ₁₆														UCX07-21		
UCFLX07-22	1 ³ / ₈	6 ²³ / ₃₂	5 ⁴³ / ₆₄	5 ³ / ₁₆	5 ⁸ / ₁₆	1 ¹ / ₂	5 ⁸ / ₁₆	4 ¹ / ₈	2 ¹ / ₆₄	1,9370	0,748	1 ¹ / ₂	27645	16910	UCX07-22	FLX07	2,0
UCFLX07-23	1 ⁷ / ₁₆														UCX07-23		
UCFLX08	40	179	148	22	16	40	16	111	52,2	49,2	19	M14			UCX08		
UCFLX08-24	1 ¹ / ₂														UCX08-24	FLX08	2,2
UCFLX08-25	1 ⁹ / ₁₆	7 ¹ / ₁₆	5 ⁵³ / ₆₄	5 ⁵ / ₁₆	5 ⁸ / ₁₆	1 ³⁷ / ₆₄	5 ⁸ / ₁₆	4 ³ / ₈	2 ¹ / ₁₆	1,9370	0,748	1 ¹ / ₂	32395	20235	UCX08-25		
UCFLX09	45	189	157	23	16	40	16	116	55,6	51,6	19	M14			UCX09		
UCFLX09-26	1 ⁵ / ₈														UCX09-26		
UCFLX09-27	1 ¹¹ / ₁₆														UCX09-27	FLX09	2,4
UCFLX09-28	1 ³ / ₄														UCX09-28		
UCFLX09-29	1 ¹³ / ₁₆	7 ⁷ / ₁₆	6 ³ / ₁₆	2 ⁹ / ₁₆	5 ⁸ / ₁₆	1 ³⁷ / ₆₄	5 ⁸ / ₁₆	4 ⁹ / ₁₆	2 ³ / ₁₆	2,0315	0,748	1 ¹ / ₂	33345	22135	UCX09-29		
UCFLX10	50	216	184	26	18	44	19	133	59,4	55,6	22,2	M16			UCX10		
UCFLX10-30	1 ⁷ / ₈														UCX10-30		
UCFLX10-31	1 ¹⁵ / ₁₆	8 ¹ / ₂	7 ¹ / ₄	1 ¹ / ₁₆	2 ³ / ₁₆	1 ²³ / ₁₆	3 ⁴ / ₁₆	5 ¹ / ₄	2 ¹¹ / ₁₆	2,1890	0,874	5 ⁸ / ₁₆	41230	27930	UCX10-31	FLX10	3,4
UCFLX10-32	2														UCX10-32		

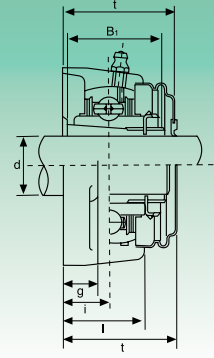
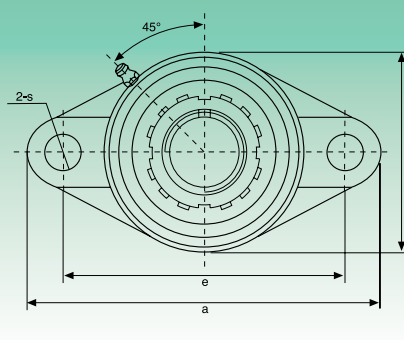
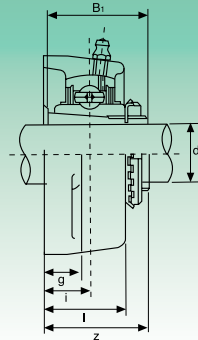
UKFL2 Serie normale - Standard duty

Tipo Type	Dimensioni - Dimensions											Bull. fiss. Bolt Size	Coefficients di carico (N) Load ratings (N)		Cuscinetto Bearing	Supporto Housing	Peso Weight	
	d	a	e	i	g	l	s	b	z	t	B ₁		Dinamico C Dynamic C	Statico C ₀ Static C ₀				kg
	mm/inch												mm/inch					
UKFL205+H2305	20	130	99	16	13	27	16	68	35,5	40	35	M14	13300	7457	UK205+H2305	FL205	0,63	
UKFL205+HE2305	¾	5 1/8	3 7/8	5/8	1/2	1 1/16	5/8	2 11/16	1 25/64	1 1/16	1,378	1/2			UK205+HE2305			
UKFL206+H2306	25	148	117	18	13	31	16	80	39	44,5	38	M14	18525	10735	UK206+H2306	FL206	0,90	
UKFL206+HS2306	7/8	5 3/16	4 3/8	45/64	1/2	1 7/32	5/8	3 3/32	1 17/32	1 3/4	1,496	1/2			UK206+HS2306			
UKFL206+HE2306	1														UK206+HE2306			
UKFL207+H2307	30	161	130	19	14	34	16	90	42,5	48,5	43	M14	24415	14630	UK207+H2307	FL207	1,17	
UKFL207+HS2307	1 1/8	6 11/32	5 1/8	3/4	3/8	1 11/32	5/8	3 35/64	1 43/64	1 29/32	1,693	1/2			UK207+HS2307			
UKFL208+H2308	35	175	144	21	14	36	16	100	46,5	55,5	46	M14	27645	16910	UK208+H2308	FL208	1,54	
UKFL208+HE2308	1 1/4	6 7/8	5 43/64	53/64	3/8	1 13/32	5/8	3 15/16	1 53/64	2 3/16	1,811	1/2			UK208+HE2308			
UKFL208+HS2308	1 3/8														UK208+HS2308			
UKFL209+H2309	40	188	148	22	15	38	19	108	48,5	56,5	50	M16	32395	20235	UK209+H2309	FL209	1,89	
UKFL209+HA2309	1 7/16																	
UKFL209+HE2309	1 1/2	7 13/32	5 53/64	55/64	1 1/32	1 1/2	3/4	4 1/4	1 29/32	2 7/32	1,969	5/8			UK209+HE2309			
UKFL209+HS2309	1 5/8														UK209+HS2309			
UKFL210+H2310	45	197	157	22	15	40	19	115	50	59,5	55	M16	33345	22135	UK210+H2310	FL210	2,27	
UKFL210+HS2310	1 5/8																	
UKFL210+HA2310	1 11/16	7 3/4	6 3/16	53/64	1 1/32	1 37/64	3/4	4 17/32	1 31/32	2 11/32	2,165	5/8			UK210+HA2310			
UKFL210+HE2310	1 3/4														UK210+HE2310			
UKFL211+H2311	50	224	184	25	18	43	19	130	54,5	63	59	M16	41230	27930	UK211+H2311	FL211	3,06	
UKFL211+HS2311	1 7/8																	
UKFL211+HA2311	1 5/16	8 3/16	7 1/4	63/64	23/32	1 11/16	3/4	5 3/8	2 3/4	2 15/32	2,323	5/8			UK211+HA2311			
UKFL211+HE2311	2														UK211+HE2311			
UKFL212+H2312	55	250	202	29	18	48	23	140	61	73,5	62	M20	49780	34390	UK212+H2312	FL212	3,79	
UKFL212+HS2312	2 1/8	9 27/32	7 5/8	1 1/64	23/32	1 7/8	2 1/32	5 1/2	2 13/32	2 57/64	2,441	3/4						
UKFL213+H2313	60	258	210	30	22	50	23	155	64	74,5	65	M20	54340	38095	UK213+H2313	FL213	4,48	
UKFL213+HA2313	2 3/16																	
UKFL213+HE2313	2 1/4	10 5/32	8 7/16	1 3/16	7/8	1 31/32	2 1/32	6 3/64	2 33/64	2 15/16	2,559	3/4			UK213+HE2313			
UKFL213+HS2313	2 5/8														UK213+HS2313			
UKFL215+H2315	65	275	225	34	22	56	23	165	71	-	73	M20	64030	45885	UK215+H2315	FL215	5,48	
UKFL215+HA2315	2 5/16																	
UKFL215+HE2315	2 1/2	10 3/16	8 5/8	1 11/32	7/8	2 7/32	2 1/32	6 1/2	2 51/64	-	2,874	3/4			UK215+HE2315			
UKFL216+H2316	70	290	233	34	22	58	25	180	73,5	-	78	M22	69065	50350	UK216+H2316	FL216	7,46	
UKFL216+HA2316	2 11/16																	
UKFL216+HE2316	2 3/4	11 13/32	9 11/64	1 11/32	7/8	2 29/32	63/64	7 3/32	2 57/64	-	3,071	7/8			UK216+HE2316			
UKFL217+H2317	75	305	248	36	24	63	25	190	77	-	82	M22	79800	58805	UK217+H2317	FL217	9,03	
UKFL217+HA2317	2 15/16																	
UKFL217+HE2317	3	12	9 49/64	1 27/64	1 1/16	2 15/32	63/64	7 15/32	3 1/32	-	3,228	7/8			UK217+HE2317			
UKFL218+H2318	80	320	265	40	24	68	25	205	81,5	-	86	M22	91295	67925	UK218+H2318	FL218	10,89	
UKFL218+HA2318	3 3/16	12 19/32	10 7/16	1 37/64	1 1/16	2 11/16	63/64	8 1/16	3 13/64	-	3,386	7/8						

Bussole HA; HE; HS con filettatura in pollici
Inch dimension adapter sleeves HA; HE; HS

UKFLX Serie media - Medium duty

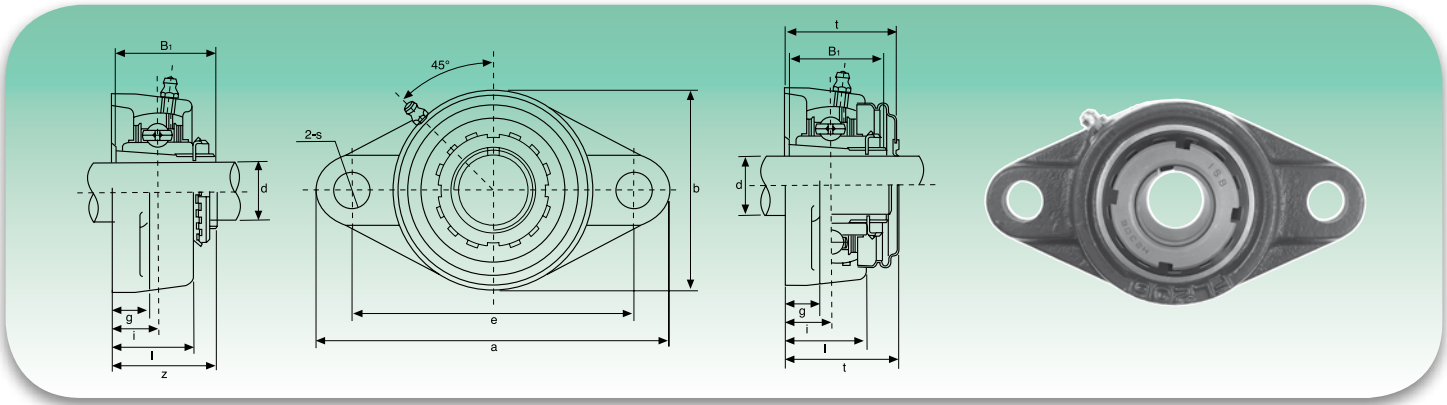

Tipo Type	Dimensioni - Dimensions										Bull. fiss. Bolt Size	Coefficienti di carico (N) Load ratings (N)		Cuscinetto Bearing	Supporto Housing	Peso Weight	
	d	a	e	i	g	l	s	b	z	B ₁		Dinamico C Dynamic C	Statico C ₀ Static C ₀				kg
	mm/inch											mm/inch					
UKFLX05+H2305	20	141	117	18	13	30	12	83	39	35	M10	18525	10735	UKX05+H2305	FLX05	1,0	
UKFLX05+HE2305	3/4	5 5/16	4 39/64	4 5/64	1/2	1 3/16	1 1/32	3 3/32	1 11/32	1,378	3/8			UKX05+HE2305			
UKFLX06+H2306	25	156	130	19	15	34	16	95	41,5	38	M14	24415	14630	UKX06+H2306	FLX06	1,5	
UKFLX06+HS2306	7/8	6 5/32	5 1/8	3/4	1 9/32	1 11/32	5/8	3 3/4	1 41/64	1,496	1/2			UKX06+HS2306			
UKFLX06+HE2306	1													UKX06+HE2306			
UKFLX07+H2307	30	171	144	21	16	38	16	105	45,5	43	M14	27645	16910	UKX07+H2307	FLX07	1,8	
UKFLX07+HS2307	1 1/8	6 23/32	5 43/64	5 3/64	5/8	1 1/2	5/8	4 1/8	1 51/64	1,693	1/2			UKX07+HS2307			
UKFLX08+H2308	35	179	148	22	16	40	16	111	47,5	46	M14	32395	20235	UKX08+H2308	FLX08	2,1	
UKFLX08+HE2308	1 1/4	7 1/16	5 53/64	5 5/64	5/8	1 9/16	5/8	4 3/8	1 7/8	1,811	1/2			UKX08+HE2308			
UKFLX08+HS2308	1 3/8													UKX08+HS2308			
UKFLX09+H2309	40	189	157	23	16	40	16	116	50	50	M14	33345	22135	UKX09+H2309	FLX09	2,5	
UKFLX09+HA2309	1 1/16	7 7/16	6 3/16	2 9/32	5/8	1 37/64	5/8	4 9/16	1 31/32	1,969	1/2			UKX09+HA2309			
UKFLX09+HE2309	1 1/2													UKX09+HE2309			
UKFLX09+HS2309	1 5/8													UKX09+HS2309			
UKFLX10+H2310	45	216	184	26	18	44	19	133	55,5	55	M16	41230	27930	UKX10+H2310	FLX10	3,7	
UKFLX10+HS2310	1 5/8	8 1/2	7 1/4	1 1/32	2 3/32	1 23/32	3/4	5 1/4	2 3/16	2,165	5/8			UKX10+HS2310			
UKFLX10+HA2310	1 11/16													UKX10+HA2310			
UKFLX10+HE2310	1 3/4													UKX10+HE2310			

Bussole HA; HE; HS con filettatura in pollici
Inch dimension adapter sleeves HA; HE; HS

HCT2 Serie normale - Normal duty

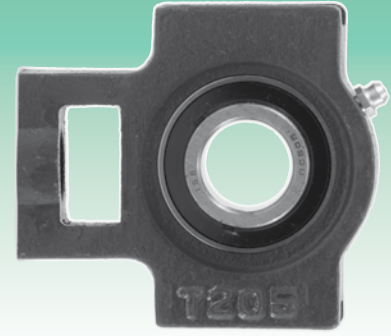
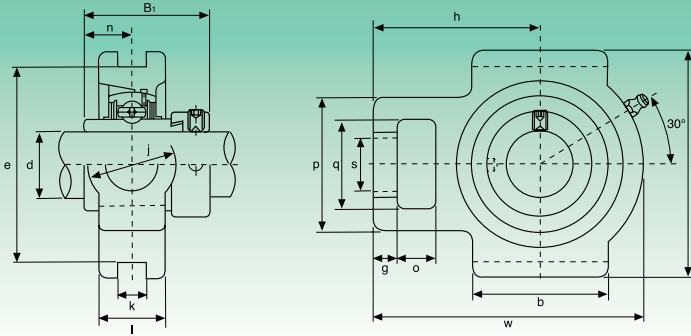

Tipo Type	Dimensioni - Dimensions																Coefficients di carico (N) Load ratings (N)		Cuscinetto Bearing	Supporto Housing	Peso Weight
	d	o	g	p	q	s	b	k	e	a	w	j	i	h	B ₁	n	Dinamico C Dynamic C ₀	Statico C ₀ Static C ₀			
	mm/inch																				
HCT204	20																12160	6318	HC204	T204	0,83
HCT204-12	3/4	5/8	25/64	1 1/16	1 1/4	3/4	2 1/64	15/32	2 63/64	3 1/2	3 11/16	1 1/4	15/16	2 13/32	1,720	0,673			HC204-12		0,83
HCT205	25	16	10	51	32	19	51	12	76	89	97	32	24	62	44,4	17,5	13300	7457	HC205	T205	0,88
HCT205-13	13/16																		HC205-13		0,93
HCT205-14	7/8																		HC205-14		0,92
HCT205-15	15/16	5/8	25/64	1 1/16	1 1/4	3/4	2 1/64	15/32	2 63/64	3 1/2	3 13/16	1 1/4	15/16	2 7/16	1,748	0,689			HC205-15		0,90
HCT205-16	1																		HC205-16		0,88
HCT206	30	16	10	56	37	22	57	12	89	102	113	37	28	70	48,4	18,3			18525		10735
HCT206-17	1 1/16																HC206-17	1,40			
HCT206-18	1 1/8																HC206-18	1,37			
HCT206-19	1 3/16	5/8	25/64	2 7/32	1 29/64	5/64	2 1/4	15/32	3 1/2	4 1/64	4 29/64	1 29/64	1 3/32	2 3/4	1,906	0,720	HC206-19	1,35			
HCT206-20	1 1/4																HC206-20	1,32			
HCT207	35	16	13	64	37	22	64	12	89	102	129	37	30	78	51,1	18,8	24415	14630	HC207	T207	1,56
HCT207-20	1 1/4																		HC207-20		1,63
HCT207-21	1 5/16																		HC207-21		1,59
HCT207-22	1 3/8	5/8	33/64	2 33/64	1 29/64	5/64	2 33/64	15/32	3 1/2	4 1/64	5 5/64	1 29/64	1 3/16	3 5/64	2,012	0,740			HC207-22		1,56
HCT207-23	1 7/16																		HC207-23		1,53
HCT208	40	19	16	83	49	29	83	16	102	114	144	49	35	89	56,3	21,4	27645	16910	HC208	T208	2,55
HCT208-24	1 1/2																		HC208-24		2,60
HCT208-25	1 9/16	3/4	5/8	3 17/64	1 15/16	1 9/64	3 17/64	5/8	4 1/64	4 31/64	5 43/64	1 15/16	1 3/8	3 1/2	2,217	0,843			HC208-25		2,56
HCT209	45	19	16	83	49	29	83	16	102	117	144	49	35	87	56,3	21,4	32395	20235	HCF209	T209	2,53
HCT209-26	1 5/8																		HC209-26		2,64
HCT209-27	1 11/16	3/4	5/8	3 17/64	1 15/16	1 9/64	3 17/64	5/8	4 1/64	4 39/64	5 43/64	1 15/16	1 3/8	3 27/64	2,217	0,843			HC209-27		2,59
HCT209-28	1 3/4																		HC209-28		2,55
HCT210	50	19	16	83	49	29	86	16	102	117	149	49	35	90	6,7	24,6	33345	22135	HCF210	T210	2,62
HCT210-29	1 13/16																		HC210-29		2,77
HCT210-30	1 7/8																		HC210-30		2,71
HCT210-31	1 15/16	3/4	5/8	3 17/64	1 15/16	1 9/64	3 25/64	5/8	4 1/64	4 39/64	5 55/64	1 15/16	1 3/8	3 39/64	2,469	0,969			HC210-31		2,65
HCT210-32	2																HC210-32	2,59			
HCT211	55	25	19	102	64	35	95	22	130	146	171	64	41	106	71,4	27,8	41230	27930	HCF211	T211	4,32
HCT211-32	2																		HC211-32		4,52
HCT211-33	2 1/8																		HC211-33		4,44
HCT211-34	2 1/8	63/64	3/4	4 1/64	2 1/32	1 3/8	3 3/4	55/64	5 1/8	5 3/4	6 47/64	2 33/64	1 3/8	4 11/64	2,811	1,094			HC211-34		4,37
HCT211-35	2 3/16																		HC211-35		4,29
HCT212	60	32	19	102	64	35	102	22	130	146	194	64	46	119	77,8	31	49780	34390	HC212	T212	5,31
HCT212-36	2 1/4																		HC212-36		5,47
HCT212-37	2 5/16																		HC212-37		5,38
HCT212-38	2 3/8	1 17/64	3/4	4 1/64	2 1/32	1 3/8	4 1/64	55/64	5 1/8	5 3/4	7 41/64	2 33/64	1 13/16	4 11/16	3,063	1,220			HC212-38		5,33
HCT212-39	2 7/16																		HC212-39		5,20
HCT213	65	32	21	111	70	41	121	26	151	167	224	70	51	137	85,7	34,1	54340	38095	HC213	T213	7,21
HCT213-40	2 1/2																		HC213-40		7,31
HCT213-41	2 9/16	1 17/64	53/64	4 3/8	2 3/4	1 39/64	4 49/64	1 1/32	5 15/16	6 37/64	8 13/16	2 3/4	2	5 25/64	3,374	1,343			HC213-41		7,20
HCT214	70	32	21	111	70	41	121	26	151	167	224	70	46	137	85,7	34,1	59090	41895	HC214	T214	7,55
HCT214-42	2 3/8																		HC214-42		7,79
HCT214-43	2 11/16	1 17/64	53/64	4 3/8	2 3/4	1 39/64	4 49/64	1 1/32	5 15/16	6 37/64	8 13/16	2 3/4	1 13/16	5 25/64	3,374	1,343			HC214-43		7,68
HCT214-44	2 3/4																		HC214-44		7,56
HCT215	75	32	21	111	70	41	121	26	151	167	232	70	48	140	92,1	37,3	64030	45885	HC215	T215	8,04
HCT215-45	2 13/16																		HC215-45		8,34
HCT215-46	2 7/8																		HC215-46		8,21
HCT215-47	2 15/16	1 17/64	53/64	4 3/8	2 3/4	1 39/64	4 49/64	1 1/32	5 15/16	6 37/64	9 9/64	2 3/4	1 57/64	5 33/64	3,626	1,426			HC215-47		8,08
HCT215-48	3																		HC215-48		7,94

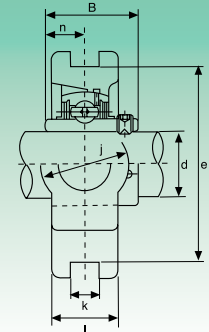
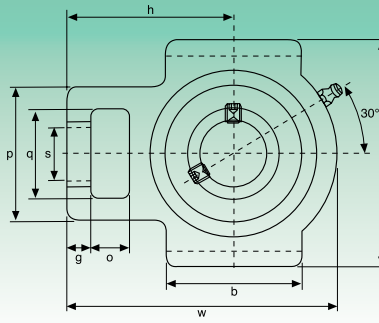
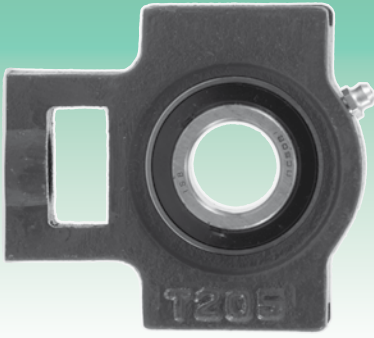

Tipo Type	Dimensioni - Dimensions															Coefficients di carico (N) Load ratings (N)		Cuscinetto Bearing	Supporto Housing	Peso Weight	
	d	o	g	p	q	s	b	k	e	a	w	j	l	h	B	n	Dinamico C Dynamic C				Statico C _o Static C _o
	mm/inch																				
UCT305 UCT305-13 UCT305-14 UCT305-15 UCT305-16	25 1 13/16	16 5/8	14 9/16	62 2 1/2	36 1 1/2	26 1 1/2	65 2 5/8	12 0,472	80 3 1/2	89 3 1/2	122 4 13/16	36 1 1/2	26 1 1/2	76 3	38 1,4961	15 0,591	20140	10355	UC305 UC305-13 UC305-14 UC305-15 UC305-16	T305	1,4
UCT306 UCT306-17 UCT306-18 UCT306-19	30 1 1/16	18 3/4	16 5/8	70 2 3/4	41 1 5/8	28 1 3/4	74 2 29/32	16 0,630	90 3 5/16	100 3 1/8	137 5 1/8	41 1 5/8	28 1 1/4	85 3 1/8	43 1,6929	17 0,669	25365	14250	UC306 UC306-17 UC306-18 UC306-19	T306	1,8
UCT307 UCT307-20 UCT307-21 UCT307-22 UCT307-23	35 1 1/4	20 1 1/16	17 25/32	75 4 3/64	45 2 1/16	30 1 29/32	80 1 3/16	16 2 5/32	100 0,630	111 3 1/16	150 4 3/8	45 5 29/32	32 1 29/32	94 1 1/4	48 3 1/16	19 1,8898	31730	18335	UC307 UC307-20 UC307-21 UC307-22 UC307-23	T307	2,4
UCT308 UCT308-24 UCT308-25	40 1 1/2	22 7/8	19 3/4	83 3 1/64	50 1 3/32	32 1 1/4	89 3 1/2	18 0,709	112 4 1/32	124 4 7/8	162 6 3/8	50 1 29/32	34 1 1/2	100 3 1/8	52 2,0472	19 0,748	38665	22800	UC308 UC308-24 UC308-25	T308	3,0
UCT309 UCT309-26 UCT309-27 UCT309-28	45 1 3/8	24 1 1/16	20 1 5/16	90 2 5/32	55 3 1/32	34 2 5/32	97 1 1/2	18 0,709	125 4 5/64	138 5 1/8	178 7	55 2 5/32	38 1 1/2	110 4 1/32	57 2,2441	22 0,866	46455	28025	UC309 UC309-26 UC309-27 UC309-28	T309	4,0
UCT310 UCT310-29 UCT310-30 UCT310-31	50 1 13/16	27 1 1/8	22 7/8	98 3 27/32	61 2 1/32	37 1 1/2	106 4 3/8	20 0,787	140 5 3/64	151 5 1/8	192 7 3/8	61 2 1/32	40 1 5/8	118 4 29/32	61 2,4016	22 0,866	58900	36385	UC310 UC310-29 UC310-30 UC310-31	T310	5,0
UCT311 UCT311-32 UCT311-33 UCT311-34 UCT311-35	55 2	29 2 1/16	23 2 1/8	105 4 1/8	66 2 1/32	39 1 17/32	115 4 17/32	22 0,866	150 5 29/32	163 6 1/32	207 8 5/32	66 2 1/32	44 1 23/32	127 5	66 2,5984	25 0,984	68020	42750	UC311 UC311-32 UC311-33 UC311-34 UC311-35	T311	6,4
UCT312 UCT312-36 UCT312-37 UCT312-38 UCT312-39	60 2 1/4	31 1 7/32	25 3 1/32	113 4 1/16	71 2 29/32	41 1 5/8	123 4 27/32	22 0,866	170 6 1/64	190 7	238 8 29/32	80 2 29/32	50 1 13/16	146 5 5/16	75 2,7953	30 1,024	77805	49590	UC312 UC312-36 UC312-37 UC312-38 UC312-39	T312	7,6
UCT313 UCT313-40 UCT313-41	65 2 1/2	32 1 17/64	27 1 1/16	116 4 9/16	70 2 3/4	43 1 11/16	134 5 9/32	26 1,024	170 6 1/16	190 7 1/8	238 9 3/8	80 3 3/32	50 1 13/16	146 5 3/4	75 2,9528	30 1,181	88065	56905	UC313 UC313-40 UC313-41	T313	9,7
UCT314 UCT314-42 UCT314-43 UCT314-44	70 2 3/8	36 2 1/8	27 1 13/32	130 5 1/8	85 3 1/32	46 1 13/16	140 5 1/2	26 1,024	180 7 3/32	202 7 1/8	252 9 29/32	90 3 1/32	52 2 1/8	155 6 3/32	78 3,2283	33 1,299	98800	64790	UC314 UC314-42 UC314-43 UC314-44	T314	11
UCT315 UCT315-45 UCT315-46 UCT315-47 UCT315-48	75 2 13/16	36 2 7/8	27 1 13/32	132 5 1/8	85 3 1/32	46 1 13/16	150 5 29/32	26 1,024	192 7 7/8	216 8 1/2	262 10 1/8	90 3 1/32	55 2 5/32	160 6 5/16	82 3,2283	32 1,260	107350	73340	UC315 UC315-45 UC315-46 UC315-47 UC315-48	T315	14
UCT316 UCT316-49 UCT316-50 UCT316-51	80 3 1/16	42 1 29/32	30 1 3/16	150 5 29/32	98 3 27/32	53 2 3/32	160 6 5/16	30 1,181	204 8 1/32	230 9 1/8	282 11 1/32	102 4 1/32	60 2 3/8	174 6 27/32	86 3,2283	34 1,260	116850	82365	UC316 UC316-49 UC316-50 UC316-51	T316	16
UCT317 UCT317-52 UCT317-53 UCT317-55	85 3 3/4	42 1 29/32	32 1 1/4	152 5 3/32	98 3 27/32	53 2 3/32	170 6 1/16	32 1,260	214 8 27/64	240 9 7/16	298 11 23/32	102 4 1/32	64 2 17/32	183 7 7/32	96 3,7795	40 1,575	126350	91960	UC317 UC317-52 UC317-53 UC317-55	T317	20
UCT318 UCT318-55 UCT318-56	90 3 3/16	46 1 13/16	32 1 1/4	160 6 5/16	106 4 3/16	57 2 1/4	175 6 7/8	32 1,260	228 8 3/32	255 10 1/32	312 12 29/32	110 4 1/32	66 2 19/32	192 7 7/16	96 3,7795	40 1,575	135850	101650	UC318 UC318-55 UC318-56	T318	22
UCT319 UCT319-58 UCT319-59 UCT319-60	95 3 3/8	46 3 1/16	33 1 1/16	165 6 1/2	106 4 3/16	57 2 1/4	180 7 3/32	35 1,378	240 9 9/64	270 10 5/8	322 12 1/16	110 4 1/32	72 2 27/32	197 7 3/4	103 4,0551	41 1,614	145350	113050	UC319 UC319-58 UC319-59 UC319-60	T319	24
UCT320 UCT320-61 UCT320-62 UCT320-63 UCT320-64	100 3 13/16	48 1 7/8	34 1 1/32	175 6 7/8	115 4 17/32	59 2 5/16	200 7 7/8	35 1,378	260 10 15/64	290 11 13/32	345 13 19/32	120 4 29/32	75 2 1/16	210 8 9/32	108 4,2520	42 1,654	164350	133950	UC320 UC320-61 UC320-62 UC320-63 UC320-64	T320	32
UCT322	110 -	52 2 1/16	38 1 1/2	185 7 9/32	125 4 29/32	65 2 5/16	215 8 15/32	38 1,496	285 11 7/32	320 12 19/32	385 15 5/32	130 5 1/8	80 3 3/32	235 9 1/4	117 4,6063	46 1,8110	194750	171000	UC322	T322	40
UCT324	120 -	60 2 3/8	42 1 29/32	210 8 9/32	140 2 3/4	70 5 1/2	230 9 1/16	45 1,772	320 12 19/32	355 13 33/32	432 17 5/2	140 5 1/2	90 3 1/32	267 10 1/2	126 4,9606	51 2,0079	196650	175750	UC324	T324	55
UCT326	130 -	65 2 1/16	45 1 29/32	220 8 29/32	150 5 29/32	75 2 62/64	240 9 9/16	50 1,969	350 13 29/32	385 15 5/32	465 18 5/8	150 5 29/32	100 3 1/16	285 1 7/32	135 5,3150	54 2,1260	217550	203300	UC326	T326	69
UCT328	140 -	70 2 3/4	50 1 3/32	230 9 1/16	160 6 5/16	80 3 3/32	255 10 1/32	50 1,969	380 14 61/63	415 16 1/32	515 20 29/32	155 6 3/32	100 3 1/16	315 12 13/32	145 5,7086	59 2,3228	240350	233700	UC328	T328	84

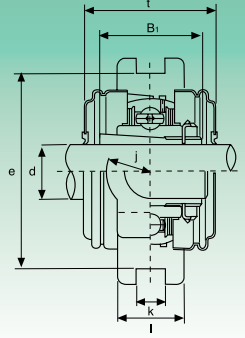
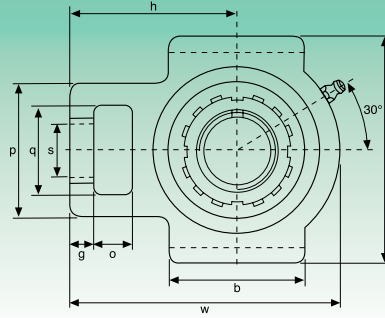
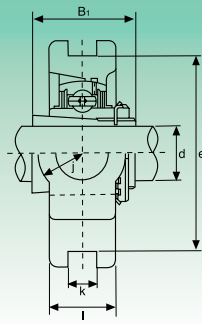
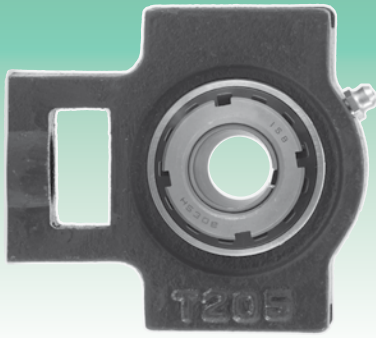
UKT2 Serie normale - Standard duty

Tipo Type	Dimensioni - Dimensions																Coefficienti di carico (N) Load ratings (N)		Cuscinetto Bearing	Supporto Housing	Peso Weight
	d	o	g	p	q	s	b	k	e	a	w	j	l	h	t	B ₁	Dinamico C Dynamic C _o	Statico C _o Static C _o			
	mm/inch																				
UKT205+H2305	20	16	10	51	32	19	51	12	76	89	97	32	24	62	48	35	13300	7457	UK205+H2305	T205	0,86
UKT205+HE2305	3/4	5/8	25/64	1 1/4	1 1/4	3/4	2 1/4	1 5/32	2 9/64	3 1/2	3 13/16	1 1/4	1 5/16	2 7/16	1 7/8	1,378		UK205+HE2305			
UKT206+H2306	25	16	10	56	37	22	57	12	89	102	113	37	28	70	53	38	18525	10735	UK206+H2306	T206	1,26
UKT206+HS2306	7/8	5/8	25/64	2 1/8	1 5/8	5/8	2 1/4	1 5/32	3 1/2	4 1/4	4 29/64	1 29/64	1 3/32	2 3/4	2 3/32	1,496		UK206+HS2306			
UKT206+HE2306	1																	UK206+HE2306			
UKT207+H2307	30	16	13	64	37	22	64	12	89	102	129	37	30	78	59,5	43	24415	14630	UK207+H2307	T207	2,50
UKT207+HS2307	1 1/8	5/8	33/64	2 3/8	1 5/8	5/8	2 3/8	1 5/32	3 1/2	4 1/4	5 5/64	1 29/64	1 3/16	3 3/64	2 1 1/2	1,693		UK207+HS2307			
UKT208+H2308	35	19	16	83	49	29	83	16	102	114	144	49	35	89	69	46	27645	16910	UK208+H2308	T208	2,50
UKT208+HE2308	1 1/4	3/4	5/8	3 1/4	1 5/8	1 3/4	3 1/4	5/8	4 1/4	4 3/8	5 43/64	1 15/16	1 3/8	3 1/2	2 23/32	1,811		UK208+HE2308			
UKT208+HS2308	1 3/8																	UK208+HS2308			
UKT209+H2309	40	19	16	83	49	29	83	16	102	117	144	49	35	87	69	50	32395	20235	UK209+H2309	T209	2,51
UKT209+HA2309	1 7/8																	UK209+HA2309			
UKT209+HE2309	1 1/2	3/4	5/8	3 1/4	1 5/8	1 3/4	3 1/4	5/8	4 1/4	4 3/8	5 43/64	1 15/16	1 3/8	3 27/64	2 23/32	1,969		UK209+HE2309			
UKT209+HS2309	1 5/8																	UK209+HS2309			
UKT210+H2310	45	19	16	83	49	29	86	16	102	117	149	49	35	90	74,5	55	33345	22135	UK210+H2310	T210	2,60
UKT210+HS2310	1 5/8																	UK210+HS2310			
UKT210+HA2310	1 11/16	3/4	5/8	3 1/4	1 5/8	1 3/4	3 25/64	5/8	4 1/4	4 39/64	5 25/64	1 15/16	1 3/8	3 39/64	2 15/16	2,165		UK210+HA2310			
UKT210+HE2310	1 3/4																	UK210+HE2310			
UKT211+H2311	50	25	19	102	64	35	95	22	130	146	171	64	41	106	76	59	41230	27930	UK211+H2311	T211	4,26
UKT211+HS2311	1 7/8																	UK211+HS2311			
UKT211+HA2311	1 5/8	63/64	3/4	4 1/4	2 1/2	1 3/8	3 3/4	55/64	5 1/8	5 3/4	6 47/64	2 23/64	1 5/8	4 1/64	3	2,323		UK211+HA2311			
UKT211+HE2311	2																	UK211+HE2311			
UKT212+H2312	55	32	19	102	64	35	102	22	130	146	194	64	46	119	89	62	49780	34390	UK212+H2312	T212	5,02
UKT212+HS2312	2 1/8	1 17/64	3/4	4 1/4	2 1/2	1 3/8	4 1/4	55/64	5 1/8	5 3/4	7 41/64	2 23/64	1 13/16	4 11/16	3 1/2	2,441		UK212+HS2312			
UKT213+H2313	60	32	21	111	70	41	121	26	151	167	224	70	51	137	89	65	54340	38095	UK213+H2313	T213	6,56
UKT213+HA2313	2 3/8																	UK213+HA2313			
UKT213+HE2313	2 1/4	1 17/64	53/64	4 3/8	2 3/4	1 39/64	4 49/64	1 1/2	5 1/16	6 37/64	8 13/16	2 3/4	2	5 25/64	3 1/2	2,559		UK213+HE2313			
UKT213+HS2313	2 3/8																	UK213+HS2313			
UKT215+H2315	65	32	21	111	70	41	121	26	151	167	232	70	48	140	-	73	64030	45885	UK215+H2315	T215	7,52
UKT215+HA2315	2 5/8																	UK215+HA2315			
UKT215+HE2315	2 1/2	1 17/64	53/64	4 3/8	2 3/4	1 39/64	4 49/64	1 1/2	5 1/16	6 37/64	9 9/64	2 3/4	1 57/64	5 33/64	-	2,874		UK215+HE2315			
UKT216+H2316	70	32	21	111	70	41	121	26	165	184	235	70	51	140	-	78	69065	50350	UK216+H2316	T216	8,56
UKT216+HA2316	2 11/16																	UK216+HA2316			
UKT216+HE2316	2 3/4	1 17/64	53/64	4 3/8	2 3/4	1 39/64	4 49/64	1 1/2	6 1/2	7 1/4	9 1/4	2 3/4	2	5 33/64	-	3,071		UK216+HE2316			
UKT217+H2317	75	38	29	124	73	48	157	30	173	198	260	73	54	162	-	82	79800	58805	UK217+H2317	T217	11,38
UKT217+HA2317	2 5/8																	UK217+HA2317			
UKT217+HE2317	3	1 1/2	1 3/4	4 7/8	2 7/8	1 57/64	6 3/16	1 3/16	6 13/16	7 5/16	10 15/64	2 7/8	2 1/8	6 3/8	-	3,228		UK217+HE2317			

Bussole HA; HE; HS con filettatura in pollici
Inch dimension adapter sleeves HA; HE; HS

UKTX Serie media - Medium duty

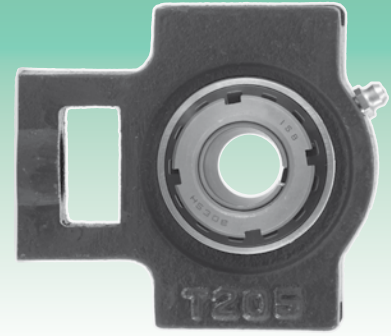
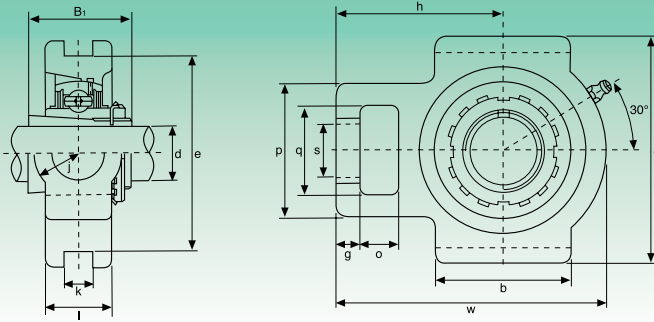

Tipo Type	Dimensioni - Dimensions															Coefficienti di carico (N) Load ratings (N)		Cuscinetto Bearing	Supporto Housing	Peso Weight
	d	o	g	p	q	s	b	k	e	a	w	l	j	h	B ₁	Dinamico C Dynamic C ₀	Statico C ₀ Static C ₀			
	mm/inch																			
UKTX05+H2305	20	16	12	56	37	22	57	12	89	102	113	28	37	70	35	18525	10735	UKX05+H2305	TX05	1,3
UCTX05+HE2305	3/4	5/8	19/32	2 1/2	1 29/64	55/64	2 1/4	0,472	3 1/2	4 1/64	4 29/64	1 1/32	1 29/64	2 3/4	1,378		UKX05+HE2305			
UKTX06+H2306	25	16	15	64	37	22	64	12	89	102	129	30	37	78	38	24415	14630	UKX06+H2306	TX06	1,7
UKTX06+HS2306	7/8																	UKX06+HS2306		
UKTX06+HE2306	1	5/8	19/32	2 33/64	1 29/64	55/64	2 33/64	0,472	3 1/2	4 1/64	5 5/64	1 3/16	1 29/64	3 5/64	1,496		UKX06+HE2306			
UKTX07+H2307	30	19	17	83	49	29	83	16	102	114	144	36	49	88	43	27645	16910	UKX07+H2307	TX07	2,6
UKTX07+HS2307	1 1/8	3/4	2 1/32	3 17/64	1 15/16	1 5/64	3 17/64	0,630	4 1/64	4 33/64	5 43/64	1 13/32	1 15/16	3 15/32	1,811		UKX07+HS2307			
UKTX08+H2308	35	19	17	83	49	29	83	16	102	117	144	36	49	87	46	32395	20235	UKX08+H2308	TX08	2,6
UKTX08+HE2308	1 1/4																	UKX08+HE2308		
UKTX08+HS2308	1 3/8	3/4	2 1/32	3 17/64	1 15/16	1 5/64	3 17/64	0,630	4 1/64	4 39/64	5 43/64	1 13/32	1 15/16	3 27/64	1,811		UKX08+HS2308			
UKTX09+H2309	40	19	18	83	49	29	86	16	102	117	151	38	49	92	50	33345	22135	UKX09+H2309	TX09	2,9
UKTX09+HA2309	1 7/16																	UKX09+HA2309		
UKTX09+HE2309	1 1/2	3/4	2 3/32	3 17/64	1 15/16	1 5/64	3 25/64	0,630	4 1/64	4 39/64	5 51/64	1 1/2	1 15/16	3 5/8	1,969		UKX09+HE2309			
UKTX09+HS2309	1 5/8																	UKX09+HS2309		
UKTX10+H2310	45	25	21	102	64	35	95	22	130	146	171	42	64	106	55	41230	27930	UKX10+H2310	TX10	4,4
UKTX10+HS2310	1 5/8																	UKX10+HS2310		
UKTX10+HA2310	1 11/16	63/64	1 3/16	4 1/64	2 1/32	1 3/8	3 3/4	0,866	5 1/8	5 3/4	6 47/64	1 21/32	2 33/64	4 11/64	2,165		UKX10+HA2310			
UKTX10+HE2310	1 3/4																	UKX10+HE2310		
UKTX11+H2311	50	32	21	102	64	35	102	22	130	146	194	44	64	119	59	49780	34390	UKX11+H2311	TX11	5,1
UKTX11+HS2311	1 7/8																	UKX11+HS2311		
UKTX11+HA2311	1 15/16	1 7/64	1 3/16	4 1/64	2 1/32	1 3/8	4 3/64	0,866	5 1/8	5 3/4	7 41/64	1 23/32	2 33/64	4 11/64	2,323		UKX11+HA2311			
UKTX11+HE2311	2																	UKX11+HE2311		
UKTX12+H2312	55	32	23	111	70	41	121	26	151	167	224	48	70	137	62	54340	38095	UKX12+H2312	TX12	7,3
UKTX12+HS2312	2 1/8	1 17/64	29/32	4 3/8	2 3/4	1 39/64	4 49/64	1,024	5 15/16	6 37/64	8 13/16	1 57/64	2 3/4	5 25/64	2,441		UKX12+HS2312			
UKTX13+H2313	60	32	23	111	70	41	121	26	151	167	224	48	70	137	65	59090	41895	UKX13+H2313	TX13	7,2
UKTX13+HA2313	2 3/8																	UKX13+HA2313		
UKTX13+HE2313	2 1/4	1 17/64	29/32	4 3/8	2 3/4	1 39/64	4 49/64	1,024	5 15/16	6 37/64	8 13/16	1 57/64	2 3/4	5 25/64	2,559		UKX13+HE2313			
UKTX13+HS2313	2 3/8																	UKX13+HS2313		
UKTX15+H2315	65	32	23	111	70	41	121	26	151	167	232	48	70	140	73	69065	50350	UKX15+H2315	TX15	8,4
UKTX15+HA2315	2 7/16																	UKX15+HA2315		
UKTX15+HE2315	2 3/8	1 17/64	29/32	4 3/8	2 3/4	1 39/64	4 49/64	1,024	5 15/16	6 37/64	9 9/64	1 57/64	2 3/4	5 33/64	3,559		UKX15+HE2315			
UKTX16+H2316	70	38	30	124	73	48	157	28	173	198	260	54	73	162	78	79800	58805	UKX16+H2316	TX16	11,8
UKTX16+HA2316	2 11/16																	UKX16+HA2316		
UKTX16+HE2316	2 3/4	1 1/2	1 3/16	4 7/8	2 7/8	1 57/64	6 3/16	1,102	6 13/16	7 51/64	10 15/64	2 1/8	2 7/8	6 3/8	3,071		UKX16+HE2316			
UKTX17+H2317	75	38	30	124	73	48	157	28	173	198	260	54	73	162	82	91295	67925	UKX17+H2317	TX17	11,4
UKTX17+HA2317	2 15/16																	UKX17+HA2317		
UKTX17+HS2317	3	1 1/2	1 3/16	4 7/8	2 7/8	1 57/64	6 3/16	1,102	6 13/16	7 51/64	10 15/64	2 1/8	2 7/8	6 3/8	3,228		UKX17+HE2317			

Bussole HA; HE; HS con filettatura in pollici
Inch dimension adapter sleeves HA; HE; HS

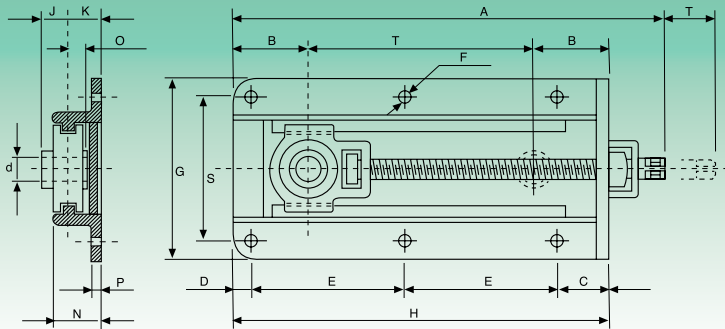
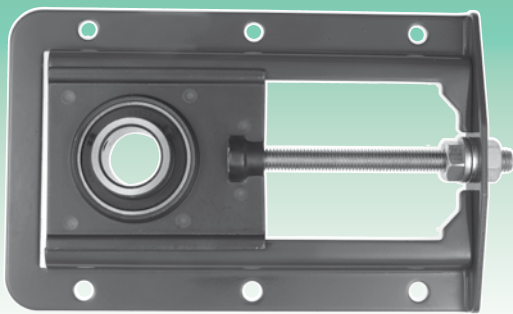
PUCT2 Serie normale - Standard duty

Tipo Type	Dimensioni - Dimensions																Peso Weight kg
	d	A	B	C	D	E	F	G	H	J	K	N	O	P	S	T	
	mm/inch																
PUCT204	20	380	80	60	20	120	11	194	320	18,3	28	45	12,7	5	154	160	4,4
PUCT205	25	380	80	60	20	120	11	194	320	19,7	28	45	14,3	5	154	160	4,4
PUCT206	30	480	95	64	20	158	11	206	400	22,2	32	45	15,9	5	166	210	6,2
PUCT207	35	480	95	64	20	158	11	206	400	25,4	32	45	17,5	5	166	210	6,5
PUCT208	40	600	105	58	22	220	13	234	520	30,2	32	50	19	5	190	310	10,9
PUCT209	45	600	105	58	22	220	13	234	520	30,2	32	50	19	5	190	310	10,8
PUCT210	50	600	105	58	22	220	13	234	520	32,6	32	50	19	5	190	310	11
PUCT211	55	680	125	55	25	250	15	284	580	33,4	45	70	22,2	6	240	330	20,4
PUCT212	60	680	125	55	25	250	15	284	580	39,7	45	70	25,4	6	240	330	21,3
PUCT213	65	790	155	66	22	306	18	303	700	39,7	51	75	25,4	6	258	390	28,3
PUCT214	70	790	155	66	22	306	18	303	700	44,4	51	75	30,2	6	258	390	28,1
PUCT215	75	790	155	66	22	306	18	303	700	44,5	51	75	33,3	6	258	390	28,7
PUCT216	80	890	165	75	25	230*	18	336	790	49,3	62	90	33,3	10	286	460	38,2
PUCT217	85	920	180	75	25	240*	18	361	820	51,6	62	100	34,1	10	311	460	44

* Piastre con quattro fori di fissaggio
Stretch skid with four fixing hole

PIASTRA CON TENDITORE PER UCT - STRETCH SKID FOR UCT
PUCTX2 Serie media - Medium duty

Tipo Type	Dimensioni - Dimensions																Peso Weight kg
	d	A	B	C	D	E	F	G	H	J	K	N	O	P	S	T	
	mm/inch																
PUCTX-05	25	480	95	64	20	158	11	206	400	22,2	32	45	15,9	5	166	210	6,8
PUCTX-06	30	480	95	64	20	158	11	206	400	25,4	32	45	17,5	5	166	210	7,0
PUCTX-07	35	600	105	58	22	220	13	234	520	30,2	32	50	19,0	5	190	310	11,1
PUCTX-08	40	600	105	58	22	220	13	234	520	30,2	32	50	19,0	5	190	310	11,1
PUCTX-09	45	600	105	58	22	220	13	234	520	32,6	32	50	19,0	5	190	310	11,3
PUCTX-10	50	680	125	55	25	250	15	284	580	33,4	45	70	22,2	6	240	330	20,1
PUCTX-11	55	680	125	55	25	250	15	284	580	39,7	45	70	25,4	6	240	330	20,9
PUCTX-12	60	790	155	66	22	306	18	303	700	39,7	51	75	25,4	6	258	390	28,1
PUCTX-13	65	790	155	66	22	306	18	303	700	44,4	51	75	30,2	6	258	390	28,3
PUCTX-14	70	790	155	66	22	306	18	303	700	44,5	51	75	33,3	6	258	390	28,6
PUCTX-15	75	890	165	75	25	230*	18	336	790	49,3	62	90	33,3	10	286	460	38,1
PUCTX-16	80	920	180	75	25	240*	18	365	820	51,6	62	100	34,1	10	315	460	49,5
PUCTX-17	85	920	180	75	25	240*	18	365	820	56,3	62	100	39,7	10	315	460	49,4

* Piastre con quattro fori di fissaggio
Stretch skid with four fixing hole

UCC2 Serie normale - Standard duty

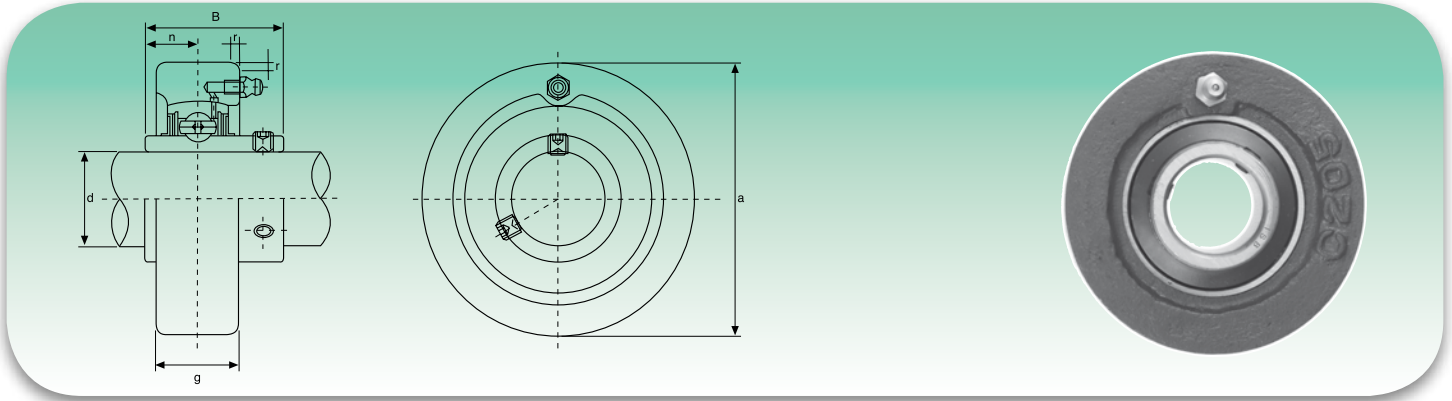

Tipo Type	Dimensioni - Dimensions						Coefficients di carico (N) Load ratings (N)		Cuscinetto Bearing	Supporto Housing	Peso Weight
	d	a	g	r	B	n	Dinamico C Dynamic C	Statico C ₀ Static C ₀			
	mm/inch										kg
UCC201	12	72	20	2	31	12,7	12160	6318	UC201	C204	0,52
UCC201-8	3/7	2,8346	25/32	0,079	1,2205	0,500			UC201-8		0,51
UCC202	15	72	20	2	31	12,7	12160	6318	UC202	C204	0,51
UCC202-9	9/16	2,8346	25/32	0,079	1,2205	0,500			UC202-9		0,51
UCC202-10	5/8								UC202-10		0,51
UCC203	17	72	20	2	31	12,7	12160	6318	UC203	C204	0,50
UCC203-11	11/16	2,8346	25/32	0,079	1,2205	0,500			UC203-11		0,49
UCC204	20	72	20	2	31	12,7	12160	6318	UC204	C204	0,48
UCC204-12	3/4	2,8346	25/32	0,079	1,2205	0,500			UC204-12		0,48
UCC205	25	80	22	2	34,1	14,3	13300	7457	UC205	C205	0,63
UCC205-13	13/16								UC205-13		0,67
UCC205-14	7/8	3,1496	55/64	0,079	1,3425	0,563			UC205-14		0,66
UCC205-15	15/16								UC205-15		0,64
UCC205-16	1								UC205-16		0,63
UCC206	30	85	27	2	38,1	15,9	18525	10735	UC206	C206	0,80
UCC206-17	1 1/16								UC206-17		0,83
UCC206-18	1 1/8	3,3465	1 1/16	0,079	1,5000	0,626			UC206-18		0,82
UCC206-19	1 3/16								UC206-19		0,80
UCC206-20	1 1/4								UC206-20		0,79
UCC207	35	90	28	2	42,9	17,5	24415	14630	UC207	C207	0,93
UCC207-20	1 1/4								UC207-20		0,99
UCC207-21	1 5/16	3,5433	1 7/64	0,079	1,6890	0,689			UC207-21		0,96
UCC207-22	1 3/8								UC207-22		0,93
UCC207-23	1 7/16								UC207-23		0,90
UCC208	40	100	30	2,5	49,2	19	27645	16910	UC208	C208	1,22
UCC208-24	1 1/2	3,9370	1 3/16	0,098	1,9370	0,748			UC208-24		1,26
UCC208-25	1 5/16								UC208-25		1,23
UCC209	45	110	31	2,5	49,2	19	32395	20235	UC209	C209	1,49
UCC209-26	1 5/8								UC209-26		1,59
UCC209-27	1 11/16	4,3307	1 7/32	0,098	1,9370	0,748			UC209-27		1,55
UCC209-28	1 3/4								UC209-28		1,51
UCC210	50	120	33	2,5	51,6	19	33345	22135	UC210	C210	1,90
UCC210-29	1 13/16								UC210-29		2,02
UCC210-30	1 7/8	4,7244	1 9/64	0,098	2,0315	0,748			UC210-30		1,97
UCC210-31	1 15/16								UC210-31		1,92
UCC210-32	2								UC210-32		1,88
UCC211	55	125	35	2,5	55,6	22,2	41230	27930	UC211	C211	2,18
UCC211-32	2								UC211-32		2,33
UCC211-33	2 1/16	4,9213	1 3/8	0,098	2,1890	0,874			UC211-33		2,27
UCC211-34	2 1/8								UC211-34		2,22
UCC211-35	2 3/16								UC211-35		2,16
UCC212	60	130	38	2,5	65,1	25,4	49780	34390	UC212	C212	2,52
UCC212-36	2 1/4								UC212-36		2,65
UCC212-37	2 5/16	5,1181	1 1/2	0,098	2,5630	1,000			UC212-37		2,57
UCC212-38	2 3/8								UC212-38		2,50
UCC212-39	2 7/16								UC212-39		2,43
UCC213	65	140	40	3	65,1	25,4	54340	38095	UC213	C213	2,98
UCC213-40	2 1/2	5,5118	1 37/64	0,118	2,5630	1,000			UC213-40		3,07
UCC213-41	2 9/16								UC213-41		2,98

Disponibile in acciaio inox Supporto: AISI 304 - Cuscinetto: AISI 440C o 420C - Available stainless steel Housing: AISI 304 - Bearing: AISI 440C or 420C
 Disponibile su richiesta con cuscinetto SA (SACC) - Available under request with SA bearing (SACC)

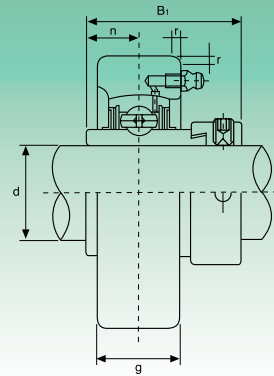
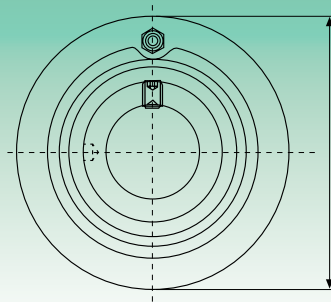
HCC2 Serie normale - Normal duty

Tipo Type	Dimensioni - Dimensions						Coefficienti di carico (N) Load ratings (N)		Cuscinetto Bearing	Supporto Housing	Peso Weight kg
	d	a	g	r	B ₁	n	Dinamico C Dynamic C _d	Statico C ₀ Static C ₀			
	mm/inch										
HCC204	20	72	20	2	43,7	17,1	12160	6318	HC204	C204	0,55
HCC204-12	¾	2,8346	25/32	0,079	1,720	0,673			0,55		
HCC205	25	80	22	2	44,4	17,5	13300	7457	HC205	C205	0,70
HCC205-13	13/16	3,1496	55/64	0,079	1,748	0,689			0,75		
HCC205-14	7/8								0,74		
HCC205-15	15/16								0,72		
HCC205-16	1								0,70		
HCC206	30	85	27	2	48,4	18,3	18525	10735	HC206	C206	0,93
HCC206-17	1 1/16	3,3465	1 1/16	0,079	1,906	0,720			0,98		
HCC206-18	1 1/8								0,95		
HCC206-19	1 3/16								0,93		
HCC206-20	1 1/4								0,90		
HCC207	35	90	28	2	51,1	18,8	24415	14630	HC207	C207	1,05
HCC207-20	1 1/4	3,5433	17/64	0,079	2,012	0,740			1,12		
HCC207-21	1 5/16								1,08		
HCC207-22	1 3/8								1,05		
HCC207-23	1 7/16								1,02		
HCC208	40	100	30	2,5	56,3	21,4	27645	16910	HC208	C208	1,37
HCC208-24	1 1/2	3,9370	1 3/16	0,098	2,217	0,843			1,42		
HCC208-25	1 9/16								1,38		
HCC209	45	110	31	2,5	56,3	21,4	32395	20235	HCF209	C209	1,66
HCC209-26	1 5/8	4,3307	17/32	0,098	2,217	0,843			1,77		
HCC209-27	1 11/16								1,72		
HCC209-28	1 3/4								1,68		
HCC210	50	120	33	2,5	62,7	24,6	33345	22135	HCF210	C210	2,09
HCC210-29	1 3/8	4,7244	1 9/64	0,098	2,469	0,969			2,24		
HCC210-30	1 7/8								2,18		
HCC210-31	1 15/16								2,12		
HCC210-32	2								2,06		
HCC211	55	125	35	2,5	71,4	27,8	41230	27930	HCF211	C211	2,39
HCC211-32	2	4,9213	1 3/8	0,098	2,811	1,094			2,59		
HCC211-33	2 1/16								2,51		
HCC211-34	2 1/8								2,44		
HCC211-35	2 3/16								2,36		
HCC212	60	130	38	2,5	77,8	31	49780	34390	HC212	C212	2,86
HCC212-36	2 1/4	5,1181	1 1/2	0,098	3,063	1,220			3,02		
HCC212-37	2 3/16								2,93		
HCC212-38	2 3/8								2,88		
HCC212-39	2 7/16								2,75		

UCC3 Serie media - Medium duty

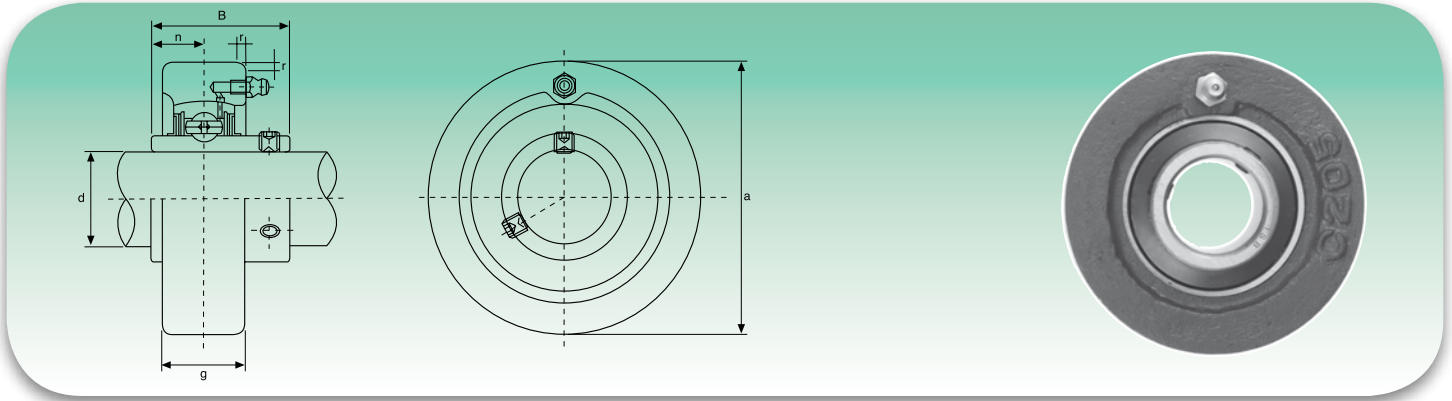

Tipo Type	Dimensioni - Dimensions						Coefficienti di carico (N) Load ratings (N)		Cuscinetto Bearing	Supporto Housing	Peso Weight
	d	a	g	r	B	n	Dinamico C Dynamic C _d	Statico C _o Static C _o			
	mm/inch										kg
UCC305	25	90	26	2,5	38	15	20140	10355	UC305	C305	1,10
UCC305-13	1 ¹³ / ₁₆										1,15
UCC305-14	7 ⁷ / ₁₆	3,5433	1 ¹ / ₃₂	0,098	1,4961	0,591					1,13
UCC305-15	1 ¹⁵ / ₁₆										1,11
UCC305-16	1										1,10
UCC306	30	100	28	2,5	43	17	25365	14250	UC306	C306	1,40
UCC306-17	1 ¹ / ₁₆										1,45
UCC306-18	1 ¹ / ₈	3,9370	1 ¹ / ₆₄	0,098	1,6929	0,669					1,42
UCC306-19	1 ³ / ₁₆										1,40
UCC307	35	110	32	3	48	19	31730	18335	UC307	C307	1,80
UCC307-20	1 ¹ / ₄										1,86
UCC307-21	5 ⁵ / ₁₆	4,3307	1 ¹ / ₆₄	0,118	1,8897	0,748					1,83
UCC307-22	1 ³ / ₈										1,80
UCC307-23	1 ⁷ / ₁₆										1,78
UCC308	40	120	34	3	52	19	38665	22800	UC308	C308	2,20
UCC308-24	1 ¹ / ₂										2,25
UCC308-25	1 ¹ / ₂	4,7244	1 ¹ / ₃₂	0,118	2,0472	0,748					2,21
UCC309	45	130	38	3,5	57	22	46455	28025	UC309	C309	2,70
UCC309-26	1 ³ / ₈										2,81
UCC309-27	1 ¹ / ₁₆	2,1181	1 ¹ / ₂	0,138	2,441	0,866					2,77
UCC309-28	1 ³ / ₄										2,72
UCC310	50	140	40	3,5	61	22	58900	36385	UC310	C310	3,30
UCC310-29	1 ¹³ / ₁₆										3,62
UCC310-30	1 ⁷ / ₈	5,118	1 ³ / ₆₄	0,138	2,4015	0,866					3,39
UCC310-31	1 ¹⁵ / ₁₆										3,33
UCC311	55	150	44	3,5	66	25	68020	42750	UC311	C311	3,90
UCC311-32	2										1,08
UCC311-33	2 ¹ / ₁₆	5,9055	1 ⁴ / ₆₄	0,138	2,5984	0,984					4,01
UCC311-34	2 ¹ / ₈										3,95
UCC311-35	2 ³ / ₁₆										3,87
UCC312	60	160	46	3,5	71	26	77805	49590	UC312	C312	4,80
UCC312-36	2 ¹ / ₄										4,95
UCC312-37	2 ⁵ / ₁₆	6,2992	1 ¹³ / ₁₆	0,138	2,7953	1,024					4,87
UCC312-38	2 ³ / ₈										4,78
UCC312-39	2 ⁷ / ₁₆										4,70
UCC313	65	170	50	3,5	75	30	88065	56905	UC313	C313	5,80
UCC313-40	2 ¹ / ₂										5,89
UCC313-41	2 ⁹ / ₁₆	6,6929	1 ³ / ₃₂	0,138	2,9528	1,181					5,89
UCC314	70	180	52	4	78	33	98800	64790	UC314	C314	6,60
UCC314-42	2 ³ / ₈										6,82
UCC314-43	2 ¹ / ₁₆	7,0866	2 ³ / ₆₄	0,157	3,0709	1,299					6,71
UCC314-44	2 ³ / ₄										6,61
UCC315	75	190	55	4	82	32	107350	73340	UC315	C315	7,80
UCC315-45	2 ¹³ / ₁₆										8,07
UCC315-46	2 ⁷ / ₈	7,4803	2 ¹ / ₆₄	0,157	3,2288	1,260					7,93
UCC315-47	2 ¹⁵ / ₁₆										7,84
UCC315-48	3										7,71
UCC316	80	200	60	4	86	34	116850	82365	UC316	C316	9,05
UCC316-49	3 ¹ / ₁₆										9,22
UCC316-50	3 ³ / ₈	7,8740	2 ²³ / ₆₄	0,157	3,3858	1,339					9,08
UCC316-51	3 ³ / ₁₆										8,99
UCC317	85	215	64	4	96	40	126350	91960	UC317	C317	10,97
UCC317-52	3 ¹ / ₄										11,19
UCC317-53	3 ³ / ₁₆	8,4646	2 ³ / ₆₄	0,157	3,7795	1,575					11,06
UCC317-54	3 ⁷ / ₁₆										10,74
UCC318	90	225	66	4	96	40	135850	101650	UC318	C318	11,96
UCC318-55	3 ⁷ / ₁₆										12,25
UCC318-56	3 ¹ / ₂	8,8583	2 ¹ / ₃₂	0,157	3,7795	1,575					12,07
UCC319	95	240	66	4	103	41	145350	113050	UC319	C319	15,00
UCC319-58	3 ³ / ₈										15,33
UCC319-59	3 ¹ / ₁₆	9,4488	2 ⁵³ / ₆₄	0,157	4,0551	1,614					15,15
UCC319-60	3 ³ / ₄										14,96
UCC320	100	260	75	4	108	42	164350	133950	UC320	C320	19,6
UCC320-64	4	10,2362	2 ⁶ / ₆₄	0,157	4,2519	1,645					19,4
UCC322	110	320	90	5	126	46					194750
		11,8110	3 ⁷ / ₃₂	0,197	4,6063	1,811					
UCC324	120	370	290	5	40	51	196650	175750	UC324	C324	
		12,5984	3 ³ / ₆₄	0,197	4,9606	2,008					
UCC326	130	340	100	5	135	54					217550
		13,3858	3 ¹ / ₁₆	0,197	5,3150	2,126					
UCC328	140	360	100	5	145	59	240350	233700	UC328	C328	
		14,1732	3 ¹ / ₁₆	0,197	5,7086	3,323					

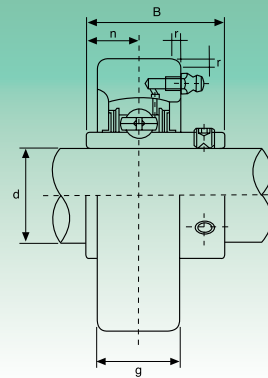
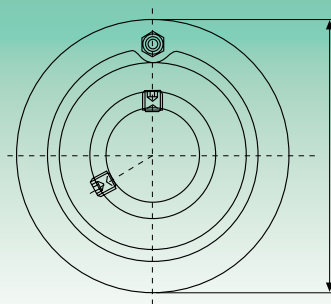

Tipo Type	Dimensioni - Dimensions						Coefficients di carico (N) Load ratings (N)		Cuscinetto Bearing	Supporto Housing	Peso Weight kg
	d	a	g	r	B	n	Dinamico C Dynamic C	Statico C ₀ Static C ₀			
	mm/inch										
UCCX05	25	90	27	2	38,1	15,9	18525	10735	UCX05	CX05	1,1
UCCX05-13	1 ³ / ₁₆										
UCCX05-14	7 ⁸ / ₁₆	3,5433	1 ¹ / ₁₆	0,079	1,5000	0,626					
UCCX05-15	1 ⁵ / ₁₆										
UCCX05-16	1										
UCCX06	30	100	30	2,5	42,9	17,5	24415	14630	UCX06	CX06	1,6
UCCX06-17	1 ¹ / ₁₆										
UCCX06-18	1 ¹ / ₈	3,9370	1 ³ / ₁₆	0,098	1,6890	0,689					
UCCX06-19	1 ³ / ₁₆										
UCCX06-20	1 ¹ / ₄										
UCCX07	35	110	34	2,5	49,2	19	27645	16910	UCX07	CX07	2,0
UCCX07-21	1 ⁵ / ₁₆										
UCCX07-22	1 ³ / ₈	4,3307	1 ¹ / ₂	0,098	1,9370	0,748					
UCCX07-23	1 ⁷ / ₁₆										
UCCX08	40	120	38	2,5	49,2	19	32395	20235	UCX08	CX08	2,5
UCCX08-24	1 ¹ / ₂	4,7244	1 ¹ / ₂	0,098	1,9370	0,748					
UCCX08-25	1 ⁹ / ₁₆										
UCCX09	45	120	38	2,5	51,6	19	33345	22135	UCX09	CX09	2,4
UCCX09-26	1 ⁵ / ₈										
UCCX09-27	1 ¹¹ / ₁₆	4,7244	1 ¹ / ₂	0,098	2,0315	0,748					
UCCX09-28	1 ³ / ₄										
UCCX09-29	1 ¹³ / ₁₆										
UCCX10	50	130	40	2,5	55,6	22,2	41230	27930	UCX10	CX10	3,0
UCCX10-30	1 ⁷ / ₈										
UCCX10-31	1 ¹⁵ / ₁₆	5,1181	1 ³ / ₄	0,098	2,1890	0,874					
UCCX10-32	2										
UCCX11	55	150	42	3	65,1	25,4	49780	34390	UCX11	CX11	4,4
UCCX11-33	2 ¹ / ₁₆										
UCCX11-34	2 ¹ / ₈										
UCCX11-35	2 ³ / ₁₆	5,9055	1 ² / ₂	0,118	2,5630	1,000					
UCCX11-36	2 ¹ / ₄										
UCCX11-37	2 ⁵ / ₁₆										
UCCX12	60	160	44	3	65,1	25,4	54340	38095	UCX12	CX12	5,0
UCCX12-38	2 ³ / ₈	6,2992	1 ⁴ / ₄	0,118	2,5630	1,000					
UCCX12-39	2 ⁷ / ₁₆										

UKC2 Serie normale - Standard duty

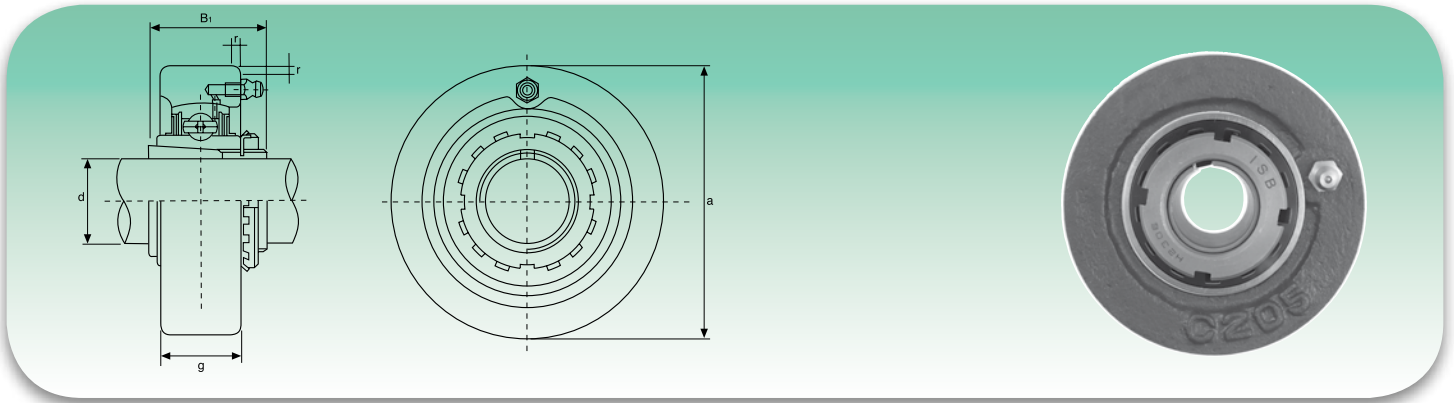

Tipo Type	Dimensioni - Dimensions					Coefficients di carico (N) Load ratings (N)		Cuscinetto Bearing	Supporto Housing	Peso Weight kg
	d	a	g	r	B ₁	Dinamico C Dynamic C	Statico C ₀ Static C ₀			
	mm/inch									
UKC205+H2305	20	80	22	2	35	13300	7457	UK205+H2305	C205	0,68
UKC205+HE2305	¾	3,1496	5⁄64	0,079	1,378			UK205+HE2305		
UKC206+H2306	25	85	27	2	38	18525	10735	UK206+H2306	C206	0,84
UKC206+HS2306	7⁄8	3,3465	1¹⁄₁₆	0,079	1,496			UK206+HS2306		
UKC206+HE2306	1							UK206+HE2306		
UKC207+H2307	30	90	28	2	43	24415	14630	UK207+H2307	C207	1,02
UKC207+HS2307	1½	3,5433	1⁷⁄₆₄	0,079	1,693			UK207+HS2307		
UKC208+H2308	35	100	30	2,5	46	27645	16910	UK208+H2308	C208	1,32
UKC208+HE2308	1¼	3,9370	1³⁄₁₆	0,098	1,811			UK208+HE2308		
UKC208+HS2308	1¾							UK208+HS2308		
UKC209+H2309	40	110	31	2,5	50	32395	20235	UK209+H2309	C209	1,64
UKC209+HA2309	1⁷⁄₁₆	4,3307	1⁷⁄₃₂	0,098	1,969			UK209+HA2309		
UKC209+HE2309	1½							UK209+HE2309		
UKC209+HS2309	1¾							UK209+HS2309		
UKC210+H2310	45	120	33	2,5	55	33345	22135	UK210+H2310	C210	2,07
UKC210+HS2310	1¾	4,7244	1¹⁹⁄₆₄	0,098	2,165			UK210+HS2310		
UKC210+HA2310	1¹¹⁄₁₆							UK210+HA2310		
UKC210+HE2310	1¾							UK210+HE2310		
UKC211+H2311	50	125	35	2,5	59	41230	27930	UK211+H2311	C211	2,33
UKC211+HS2311	1¾	4,9213	1¾	0,098	2,323			UK211+HS2311		
UKC211+HA2311	1¹⁵⁄₁₆							UK211+HA2311		
UKC211+HE2311	2							UK211+HE2311		
UKC212+H2312	55	130	38	2,5	62	49780	34390	UK212+H2312	C212	2,57
UKC212+HS2312	2½	5,1181	1½	0,098	2,441			UK212+HS2312		
UKC213+H2313	60	140	40	3	65	54340	38095	UK213+H2313	C213	2,89
UKC213+HA2313	2³⁄₁₆	5,5118	1³⁷⁄₆₄	0,118	2,559			UK213+HA2313		
UKC213+HE2313	2¼							UK213+HE2313		
UKC213+HS2313	2¾							UK213+HS2313		

Bussole HA; HE; HS con filettatura in pollici
Inch dimension adapter sleeves HA; HE; HS

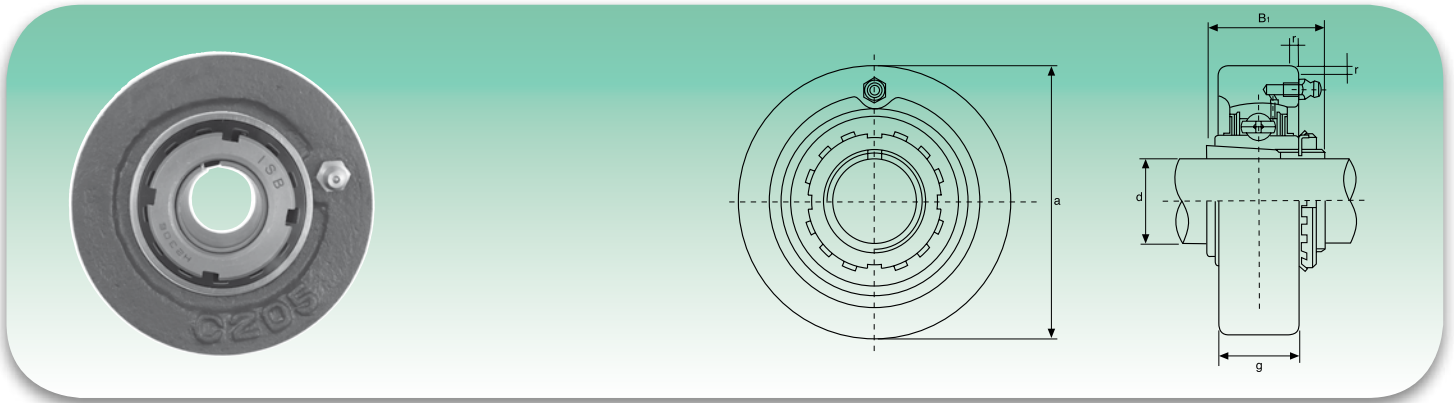
UKCX Serie media - Medium duty

Tipo Type	Dimensioni - Dimensions					Coefficienti di carico (N) Load ratings (N)		Cuscinetto Bearing	Supporto Housing	Peso Weight kg
	d	a	g	r	B ₁	Dinamico C Dynamic C	Statico C ₀ Static C ₀			
	mm/inch									
UKCX05+H2305	20	90	27	2	35	18525	10735	UKX05+H2305	CX05	0,99
UKCX05+HE2305	¾	3,5433	1 ¼	0,079	1,378			UKX05+HE2305		
UKCX06+H2306	25	100	30	2,5	38	24415	14630	UKX06+H2306	CX06	1,3
UKCX06+HS2306	⅞	3,9370	1 ⅜	0,098	1,496			UKX06+HS2306		
UKCX06+HE2306	1							UKX06+HE2306		
UKCX07+H2307	30	110	34	2,5	43	27645	16910	UKX07+H2307	CX07	1,7
UKCX07+HS2307	1 ⅛	4,3307	1 ½	0,098	1,693			UKX07+HS2307		
UKCX08+H2308	35	120	38	2,5	46	32395	20235	UKX08+H2308	CX08	2,3
UKCX08+HE2308	1 ¼	4,7244	1 ½	0,098	1,811			UKX08+HE2308		
UKCX08+HS2308	1 ⅜							UKX08+HS2308		
UKCX09+H2309	40	120	38	2,5	50	33345	22135	UKX09+H2309	CX09	2,3
UKCX09+HA2309	1 ⅞							UKX09+HA2309		
UKCX09+HE2309	1 ½	4,7244	1 ½	0,098	1,969			UKX09+HE2309		
UKCX09+HS2309	1 ⅝							UKX09+HS2309		
UKCX10+H2310	45	130	40	2,5	55	41230	27930	UKX10+H2310	CX10	2,8
UKCX10+HS2310	1 ⅝							UKX10+HS2310		
UKCX10+HA2310	1 ⅞	5,1181	1 ¾	0,098	2,165			UKX10+HA2310		
UKCX10+HE2310	1 ¾							UKX10+HE2310		
UKCX11+H2311	50	150	42	3	59	49780	34390	UKX11+H2311	CX11	3,8
UKCX11+HS2311	1 ⅞							UKX11+HS2311		
UKCX11+HA2311	1 ⅞	5,9055	1 ½	0,118	2,323			UKX11+HA2311		
UKCX11+HE2311	2							UKX11+HE2311		
UKCX12+H2312	55	130	38	2,5	62	54340	38095	UKX12+H2312	CX12	4,4
UKCX12+HS2312	2 ⅞	6,2992	1 ⅝	0,118	2,441			UKX12+HS2312		

Bussole HA; HE; HS con filettatura in pollici
Inch dimension adapter sleeves HA; HE; HS

UCPH2 Serie normale - Standard duty

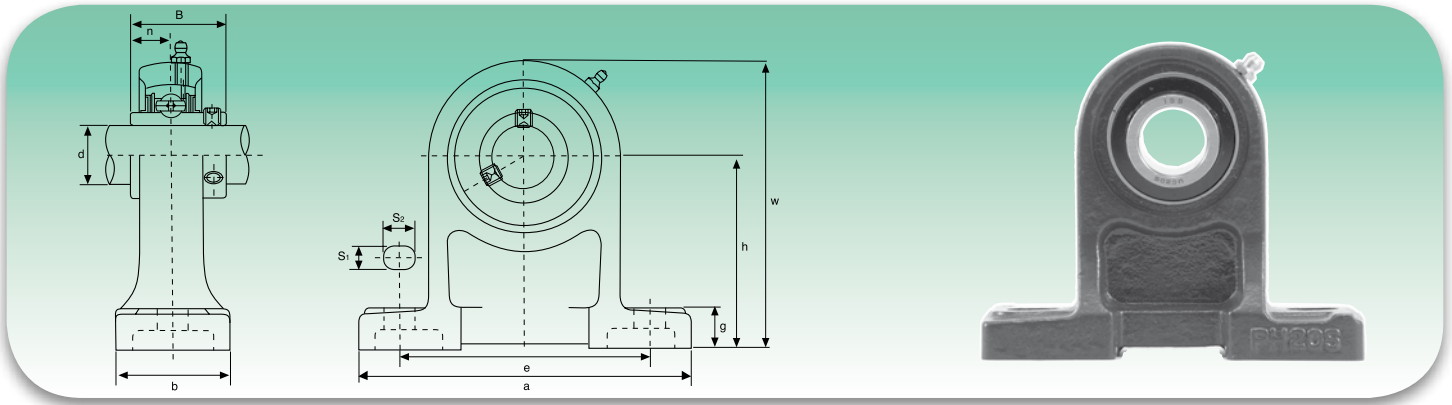

Tipo Type	Dimensioni - Dimensions											Bull. fess. Bolt Size	Coefficients di carico (N) Load ratings (N)		Cuscinetto Bearing	Supporto Housing	Peso Weight	
	d	h	a	e	b	S ₁	S ₂	g	w	B	n		Dinamico C Dynamic C	Statico C ₀ Static C ₀				kg
	mm/inch												mm/inch					
UCPH201	12	70	127	95	40	13	19	15	101	31	12,7	M10	12160	6318	UC201	PH203	0,81	
UCPH201-8	3/4	2 3/4	5	3 3/4	1 5/8	1/2	3/4	1 1/2	3 9/64	1,2205	0,500	3/8			UC201-8		0,80	
UCPH202	15	70	127	95	40	13	19	15	101	31	12,7	M10	12160	6318	UC202	PH203	0,80	
UCPH202-9	9/16	2 3/4	5	3 3/4	1 5/8	1/2	3/4	1 1/2	3 9/64	1,2205	0,500	3/8			UC202-9		0,80	
UCPH202-10	5/8														UC202-10		0,80	
UCPH203	17	70	127	95	40	13	19	15	101	31	12,7	M10	12160	6318	UC203	PH203	0,79	
UCPH203-11	1 1/16	2 3/4	5	3 3/4	1 5/8	1/2	3/4	1 1/2	3 9/64	1,2205	0,500	3/8			UC203-11		0,78	
UCPH204	20	70	127	95	40	13	19	15	101	31	12,7	M10	12160	6318	UC204	PH204	0,77	
UCPH204-12	3/4	2 3/4	5	3 3/4	1 5/8	1/2	3/4	1 1/2	3 9/64	1,2205	0,500	3/8			UC204-12		0,77	
UCPH205	25	80	140	105	50	13	19	16	114	34,1	14,3	M10			UC205		1,01	
UCPH205-13	1 3/16												13300	7457	UC205-13	PH205	1,05	
UCPH205-14	7/8														UC205-14		1,04	
UCPH205-15	1 1/4	3 3/32	5 1/2	4 1/8	1 31/32	1/2	3/4	5/8	4 31/64	1,3425	0,563	3/8			UC205-15		1,02	
UCPH205-16	1														UC205-16		1,01	
UCPH206	30	90	161	121	50	17	21	17	130	38,1	15,9	M14			UC206		1,47	
UCPH206-17	1 1/16														UC206-17	PH206	1,50	
UCPH206-18	1 1/8	3 3/64	6 11/32	4 3/4	1 31/32	4 3/64	5 3/64	4 3/64	5 1/8	1,5000	0,626	1/2	18525	10735	UC206-18		1,49	
UCPH206-19	1 3/16														UC206-19		1,47	
UCPH206-20	1 1/4														UC206-20		1,46	
UCPH207	35	95	166	127	60	17	21	18	140	42,9	17,5	M14			UC207		1,91	
UCPH207-20	1 1/4														UC207-20	PH207	1,97	
UCPH207-21	1 5/16	3 7/64	6 11/32	5	2 23/64	4 3/64	5 3/64	4 5/64	5 33/64	1,6890	0,689	1/2	24415	14630	UC207-21		1,94	
UCPH207-22	1 3/8														UC207-22		1,91	
UCPH207-23	1 7/16														UC207-23		1,88	
UCPH208	40	100	178	137	70	17	21	19	150	49,2	19	M14			UC208		2,52	
UCPH208-24	1 1/2	3 11/16	7 1/64	5 13/32	2 3/4	4 3/64	5 3/64	3/4	5 29/32	1,9370	0,748	1/2	27645	16910	UC208-24	PH208	2,56	
UCPH208-25	1 9/16														UC208-25		2,53	
UCPH209	45	105	189	146	70	17	21	20	158	49,2	19	M14			UC209		2,72	
UCPH209-26	1 5/8														UC209-26	PH209	2,82	
UCPH209-27	1 11/16	4 9/64	7 1/16	5 3/4	2 3/4	4 3/64	5 3/64	2 5/32	6 7/32	1,9370	0,748	1/2	32395	20235	UC209-27		2,78	
UCPH209-28	1 3/4														UC209-28		2,74	
UCPH210	50	110	205	159	70	20	23	21	165	51,6	19	M16			UC210		3,10	
UCPH210-29	1 13/16														UC210-29	PH210	3,22	
UCPH210-30	1 7/8	4 21/64	8 5/64	6 1/4	2 3/4	2 5/32	2 9/32	5 3/64	6 1/2	2,0315	0,748	5/8	33345	22135	UC210-30		3,17	
UCPH210-31	1 15/16														UC210-31		3,12	
UCPH210-32	2														UC210-32		3,08	
UCPH211	55	120	219	171	75	20	23	22	181	55,6	22,2	M16			UC211		-	
UCPH211-32	2														UC211-32	PH211	-	
UCPH211-33	2 1/16	4 23/32	8 5/8	6 47/64	2 61/64	2 5/32	2 9/32	5 5/64	7 1/8	2,1890	0,874	5/8	41230	27930	UC211-33		-	
UCPH211-34	2 1/8														UC211-34		-	
UCPH211-35	2 3/16														UC211-35		-	
UCPH212	60	130	241	184	85	20	23	25	197	65,1	25,4	M16			UC212		-	
UCPH212-36	2 1/4														UC212-36	PH212	-	
UCPH212-37	2 5/16	5 1/8	9 1/2	7 1/4	3 11/32	2 5/32	2 9/32	6 3/64	7 3/4	2,5630	1,000	5/8	49780	34390	UC212-37		-	
UCPH212-38	2 3/8														UC212-38		-	
UCPH212-39	2 1/2														UC212-39		-	
UCPH213	65	140	265	203	95	25	28	27	212	65,1	25,4	M20			UC213		-	
UCPH213-40	2 1/2	5 33/64	10 7/16	8	3 3/4	6 3/64	1 3/32	1 1/16	8 11/32	2,5630	1,000	3/4	54340	38095	UC213-40	PH213	-	
UCPH213-41	2 9/16														UC213-41		-	
UCPH214	70	150	266	210	105	25	28	28	225	74,6	30,2	M20			UC214		-	
UCPH214-42	2 5/8														UC214-42	PH214	-	
UCPH214-43	2 11/16	5 29/32	10 15/32	8 11/64	5 5/64	6 3/64	1 3/32	1 7/64	8 55/64	2,9370	1,189	3/4	59090	41895	UC214-43		-	
UCPH214-44	2 3/4														UC214-44		-	
UCPH215	75	160	275	217	115	25	28	29	238	77,8	33,3	M20			UC215		-	
UCPH215-45	2 13/16														UC215-45	PH215	-	
UCPH215-46	2 7/8	5 11/64	10 53/64	8 35/64	4 17/32	6 3/64	1 3/32	1 1/64	9 3/8	3,0630	1,311	3/4	64030	45885	UC215-46		-	
UCPH215-47	2 15/16														UC215-47		-	
UCPH215-48	3														UC215-48		-	
UCPH216	80	170	292	232	125	25	28	30	253	82,6	33,3	M20			UC216		-	
UCPH216-49	3 1/16														UC216-49	PH216	-	
UCPH216-50	3 3/8	6 11/16	11 1/2	9 1/8	4 59/64	6 3/64	1 3/32	1 3/16	9 1/64	3,2520	1,311	3/4	69065	50350	UC216-50		-	
UCPH216-51	3 1/2														UC216-51		-	

Disponibile in acciaio inox Supporto: AISI 304 - Cuscinetto: AISI 440C o 420C - Available stainless steel Housing: AISI 304 - Bearing: AISI 440C or 420C
 Disponibile su richiesta con cuscinetto SA (SAPH) - Available under request with SA bearing (SAPH)

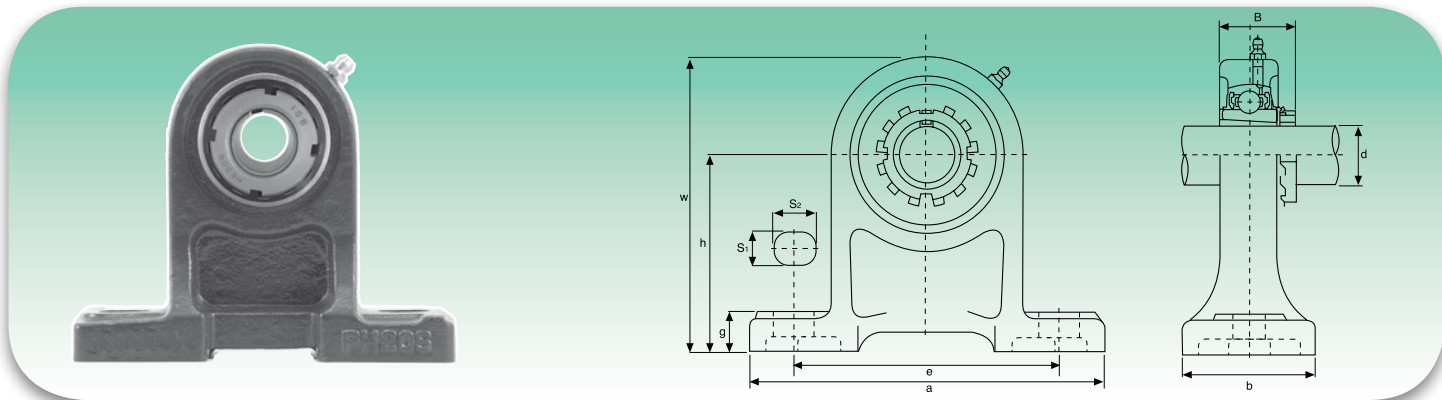
UKPH2 Serie normale - Standard duty

Tipo Type	Dimensioni - Dimensions										Bull. fiss. Bolt Size	Coefficienti di carico (N) Load ratings (N)		Cuscinetto Bearing	Supporto Housing	Peso Weight kg
	d	h	a	e	b	S ₁	S ₂	g	w	B ₁		Dinamico C Dynamic C	Statico C ₀ Static C ₀			
	mm/inch											mm/inch				
UKPH205+H2305	20	80	140	105	50	13	19	16	114	34,1	M10	13300	7457	UK205+H2305	PH205	1,24
UKPH205+HE2305	¾	3 5/32	5 1/2	4 1/8	1 31/32	½	¾	5/8	4 31/64	1,3425	¾			UK205+HE2305		
UKPH206+H2306	25	90	161	121	50	17	21	17	130	38,1	M14	18525	10735	UK206+H2306	PH206	1,64
UKPH206+HS2306	7/8	3 35/64	6 11/32	4 3/4	1 31/32	4 3/64	5 3/64	4 3/64	5 1/8	1,5000	½			UK206+HS2306		
UKPH206+HE2306	1													UK206+HE2306		
UKPH207+H2307	30	95	166	127	60	17	21	18	140	42,9	M14	24415	14630	UK207+H2307	PH207	2,03
UKPH207+HS2307	1 1/8	3 47/64	6 17/32	5	2 23/64	4 3/64	5 3/64	4 5/64	5 33/64	1,6890	½			UK207+HS2307		
UKPH208+H2308	35	100	178	137	70	17	21	19	150	49,2	M14	27645	16910	UK208+H2308	PH208	2,72
UKPH208+HE2308	1 1/4	3 15/16	7 1/64	5 13/32	2 3/4	4 3/64	5 3/64	¾	5 29/32	1,9370	½			UK208+HE2308		
UKPH208+HS2308	1 3/8													UK208+HS2308		
UKPH209+H2309	40	105	189	146	70	17	21	20	158	49,2	M14	32395	20235	UK209+H2309	PH209	3,09
UKPH209+HA2309	1 7/16	4 9/64	7 7/16	5 3/4	2 3/4	4 3/64	5 3/64	2 5/32	6 7/32	1,9370	½			UK209+HA2309		
UKPH209+HE2309	1 1/2													UK209+HE2309		
UKPH209+HS2309	1 5/8													UK209+HS2309		
UKPH210+H2310	45	110	205	159	70	20	23	21	165	51,6	M16	33345	22135	UK210+H2310	PH210	3,59
UKPH210+HS2310	1 5/8	4 23/64	8 5/64	6 1/4	2 3/4	2 5/32	2 9/32	5 3/64	6 1/2	2,0315	5/8			UK210+HS2310		
UKPH210+HA2310	1 11/16													UK210+HA2310		
UKPH210+HE2310	1 3/4													UK210+HE2310		

Bussole HA; HE; HS con filettatura in pollici
Inch dimension adapter sleeves HA; HE; HS

UCPA2 Serie normale - Standard duty

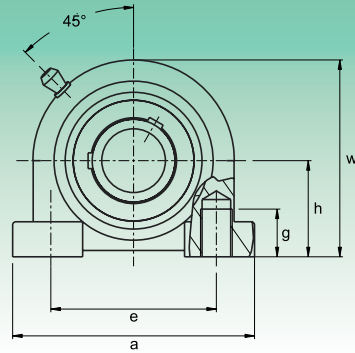
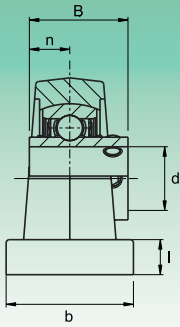

Tipo Type	Dimensioni - Dimensions										Bull. fiss. Bolt Size	Coefficienti di carico (N) Load ratings (N)		Cuscinetto Bearing	Supporto Housing	Peso Weight	
	d	h	a	e	b	g	l	w	B	n		Dinamico C Dynamic C	Statico C ₀ Static C ₀				kg
	mm/inch											mm/inch					
UCPA201	12	30,2	76	52	40	15	11	62	31	12,7	M10	12160	6318	UC201	PA204	0,60	
UCPA201-8	3/4	1 1/16	3	2 3/4	1 1/16	1 9/32	7/16	2 7/16	1,2205	0,500	3/8			UC201-8		0,59	
UCPA202	15	30,2	76	52	40	15	11	62	31	12,7	M10	12160	6318	UC202	PA204	0,59	
UCPA202-9	3/4	1 1/16	3	2 3/4	1 1/16	1 9/32	7/16	2 7/16	1,2205	0,500	3/8			UC202-9		0,59	
UCPA202-10	5/8													UC202-10		0,59	
UCPA203	17	30,2	76	52	40	15	11	62	31	12,7	M10	12160	6318	UC203	PA204	0,58	
UCPA203-11	1 1/16	1 1/16	3	2 3/4	1 1/16	1 9/32	7/16	2 7/16	1,2205	0,500	3/8			UC203-11		0,57	
UCPA204	20	30,2	76	52	40	15	11	62	31	12,7	M10	12160	6318	UC204	PA204	0,56	
UCPA204-12	3/4	1 1/16	3	2 3/4	1 1/16	1 9/32	7/16	2 7/16	1,2205	0,500	3/8			UC204-12		0,56	
UCPA205	25	36,5	84	56	38	15	12	72	34,1	14,3	M10			UC205		0,83	
UCPA205-13	1 3/16													UC205-13		0,87	
UCPA205-14	7/8	1 7/16	3 5/16	2 13/64	1 1/2	1 9/32	1 5/32	2 33/64	1,3425	0,563	3/8	13300	7457	UC205-14	PA205	0,86	
UCPA205-15	1 5/16													UC205-15		0,84	
UCPA205-16	1													UC205-16		0,83	
UCPA206	30	42,9	94	66	50	18	12	84	38,1	15,9	M14			UC206		1,12	
UCPA206-17	1 1/16													UC206-17		1,15	
UCPA206-18	1 1/8	1 11/16	3 45/64	2 19/32	1 33/32	4 5/64	1 5/32	3 3/16	1,5000	0,626	1/2	18525	10735	UC206-18	PA206	1,14	
UCPA206-19	1 3/16													UC206-19		1,12	
UCPA206-20	1 1/4													UC206-20		1,11	
UCPA207	35	47,6	110	80	55	20	13	95	42,9	17,5	M14			UC207		1,48	
UCPA207-20	1 1/4													UC207-20		1,54	
UCPA207-21	1 5/16	1 7/8	4 21/64	3 5/32	2 11/64	2 5/32	3 3/64	3 47/64	1,6890	0,689	1/2	24415	14630	UC207-21	PA207	1,51	
UCPA207-22	1 3/8													UC207-22		1,48	
UCPA207-23	1 7/16													UC207-23		1,45	
UCPA208	40	49,2	116	84	58	20	13	100	49,2	19	M14			UC208		1,89	
UCPA208-24	1 1/2	1 15/16	4 9/16	3 3/16	2 9/32	2 5/32	3 3/64	3 15/16	1,9370	0,748	1/2	27645	16910	UC208-24	PA208	1,93	
UCPA208-25	1 9/16													UC208-25		1,90	
UCPA209	45	54,2	120	90	60	25	13	108	49,2	19	M14			UC209		1,98	
UCPA209-26	1 5/8													UC209-26		2,08	
UCPA209-27	1 11/16	2 5/64	4 23/32	3 35/64	2 23/64	6 3/64	3 3/64	4 1/4	1,9370	0,748	1/2	32395	20235	UC209-27	PA209	2,04	
UCPA209-28	1 3/4													UC209-28		2,00	
UCPA210	50	57,2	130	94	64	25	14	116	51,6	19	M16			UC210		2,16	
UCPA210-29	1 13/16													UC210-29		2,28	
UCPA210-30	1 7/8	2 1/4	5 1/8	3 45/64	2 33/64	6 3/64	3 5/64	4 9/16	2,0315	0,748	5/8	33345	22135	UC210-30	PA210	2,23	
UCPA210-31	1 15/16													UC210-31		2,18	
UCPA210-32	2													UC210-32		2,14	
UCPA211	55	63,5	140	104	66	25	14	125	55,6	22,2	M16			UC211		3,26	
UCPA211-32	2													UC211-32		3,41	
UCPA211-33	2 1/16	2 1/2	5 33/64	4 3/32	2 19/32	6 3/64	3 5/64	4 59/64	2,1890	0,874	5/8	41230	27930	UC211-33	PA211	3,35	
UCPA211-34	2 1/8													UC211-34		3,30	
UCPA211-35	2 3/16													UC211-35		3,24	
UCPA212	60	69,9	150	114	68	25	15	138	65,1	25,4	M16			UC212		4,19	
UCPA212-36	2 1/4													UC212-36		4,32	
UCPA212-37	2 5/16	2 3/4	5 29/32	4 31/64	2 43/64	6 3/64	1 9/32	5 7/16	2,5630	1,000	5/8	49780	34390	UC212-37	PA212	4,24	
UCPA212-38	2 3/8													UC212-38		4,17	
UCPA212-39	2 7/16													UC212-39		4,10	
UCPA213	65	76,2	160	124	70	25	15	150	65,1	25,4	M16			UC213		-	
UCPA213-40	2 1/2	3	6 15/64	4 7/8	2 3/4	6 3/64	1 9/32	5 29/32	2,5630	1,000	5/8	54340	38095	UC213-40	PA213	-	
UCPA213-41	2 9/16													UC213-41		-	

Disponibile in acciaio inox Supporto: AISI 304 - Cuscinetto: AISI 440C o 420C - Available stainless steel Housing: AISI 304 - Bearing: AISI 440C or 420C
 Disponibile su richiesta con cuscinetto SA (SAPA) - Available under request with SA bearing (SAPA)

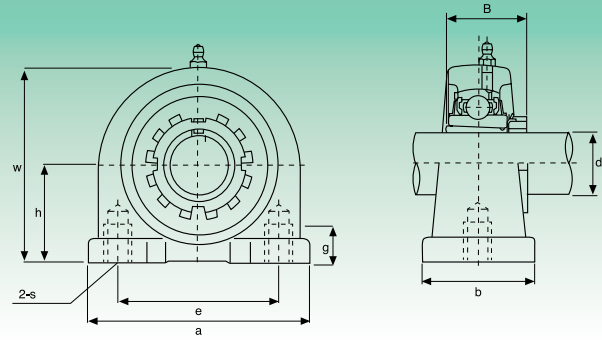
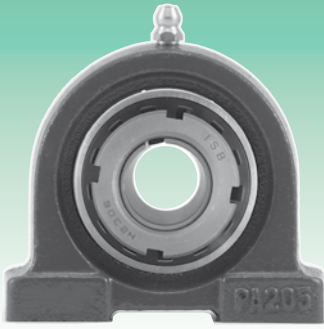
UKPA2 Serie normale - Standard duty

Tipo Type	Dimensioni - Dimensions								Bull. fiss. Bolt Size	Coefficienti di carico (N) Load ratings (N)		Cuscinetto Bearing	Supporto Housing	Peso Weight	
	d	h	a	e	b	g	W	B		Dinamico C Dynamic C	Statico C ₀ Static C ₀				kg
	mm/inch									mm/inch					
UKPA205+H2305	20	36,5	84	56	38	15	72	34,1	M10	13300	7457	UK205+H2305	PA205	0,87	
UKPA205+HE2305	¾	1 7/16	3 3/16	2 13/64	1 1/2	1 9/32	2 53/64	1,3425	¾			UK205+HE2305			
UKPA206+H2306	25	42,9	94	66	50	18	84	38,1	M14	18525	10735	UK206+H2306	PA206	1,24	
UKPA206+HS2306	7/8	1 11/16	3 4/64	2 19/32	1 31/32	4 5/64	3 3/16	1,5000	1/2			UK206+HS2306			
UKPA206+HE2306	1											UK206+HE2306			
UKPA207+H2307	30	47,6	110	80	55	20	95	42,9	M14	24415	14630	UK207+H2307	PA207	1,73	
UKPA207+HS2307	1 1/8	1 7/8	4 21/64	3 5/32	2 11/64	2 5/32	3 47/64	1,6890	1/2			UK207+HS2307			
UKPA208+H2308	35	49,2	116	84	58	20	100	49,2	M14	27645	16910	UK208+H2308	PA208	2,02	
UKPA208+HE2308	1 1/4	1 15/16	4 9/16	3 5/16	2 5/32	2 5/32	3 15/16	1,9370	1/2			UK208+HE2308			
UKPA208+HS2308	1 3/8											UK208+HS2308			
UKPA209+H2309	40	54,2	120	90	60	25	108	49,2	M14	32395	20235	UK209+H2309	PA209	2,29	
UKPA209+HA2309	1 7/16											UK209+HA2309			
UKPA209+HE2309	1 1/2	2 5/64	4 23/32	3 35/64	2 23/64	6 3/64	4 1/4	1,9370	1/2			UK209+HE2309			
UKPA209+HS2309	1 5/8											UK209+HS2309			
UKPA210+H2310	45	57,2	130	94	64	25	116	51,6	M16	33345	22135	UK210+H2310	PA210	2,89	
UKPA210+HS2310	1 5/8											UK210+HS2310			
UKPA210+HA2310	1 11/16	2 1/2	5 1/8	3 45/64	2 33/64	6 3/64	4 9/16	2,0315	5/8			UK210+HA2310			
UKPA210+HE2310	1 3/4											UK210+HE2310			

Bussole HA; HE; HS con filettatura in pollici
Inch dimension adapter sleeves HA; HE; HS

UCFA2 Serie normale - Standard duty

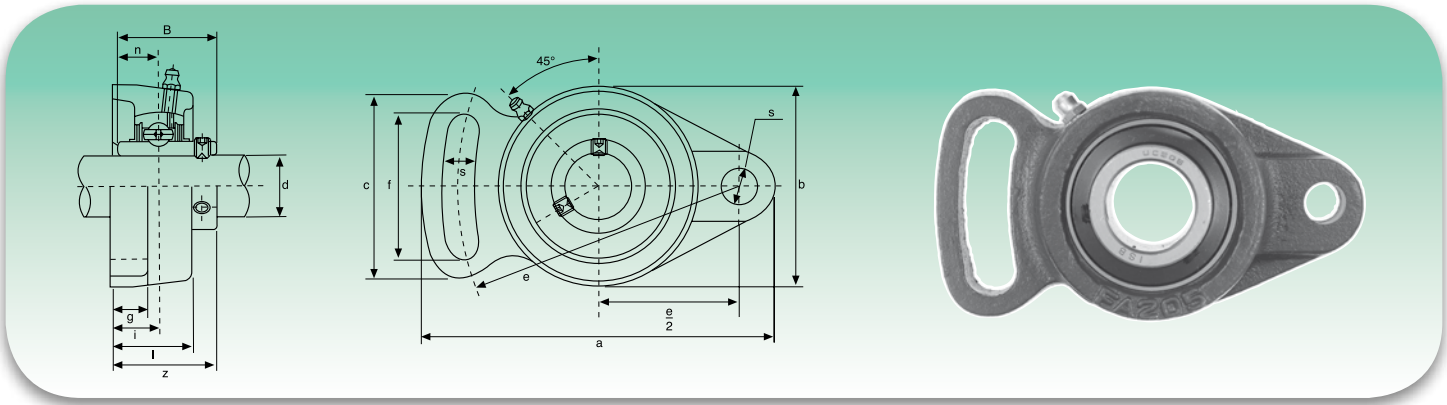

Tipo Type	Dimensioni - Dimensions													Bull. fiss. Bolt Size	Coefficients di carico (N) Load ratings (N)		Cuscinetto Bearing	Supporto Housing	Peso Weight
	d	a	e	i	g	l	s	b	z	f	c	B	n		Dinamico C Dynamic C	Statico C ₀ Static C ₀			
	mm/inch														mm/inch				
UCFA201	12	98	78	15	12	25,5	10	60	33,3	40	50	31	12,7	M8	12160	6318	UC201	FA204	0,50
UCFA201-8	3/4	3 5/64	3 3/64	1 9/32	1 15/32	1	2 5/64	2 3/8	1 1/6	1 3/64	1 3 1/2	1,2205	0,500	5/16			UC201-8		0,49
UCFA202	15	98	78	15	12	25,5	10	60	33,3	40	50	31	12,7	M8	12160	6318	UC202	FA204	0,49
UCFA202-9	9/16	3 5/64	3 3/64	1 9/32	1 15/32	1	2 5/64	2 3/8	1 1/6	1 3/64	1 3 1/2	1,2205	0,500	5/16			UC202-9		0,49
UCFA202-10	5/8	3 5/64	3 3/64	1 9/32	1 15/32	1	2 5/64	2 3/8	1 1/6	1 3/64	1 3 1/2	1,2205	0,500	5/16			UC202-10		0,49
UCFA203	17	98	78	15	12	25,5	10	60	33,3	40	50	31	12,7	M8	12160	6318	UC203	FA204	0,48
UCFA203-11	1 1/6	3 5/64	3 3/64	1 9/32	1 15/32	1	2 5/64	2 3/8	1 1/6	1 3/64	1 3 1/2	1,2205	0,500	5/16			UC203-11		0,47
UCFA204	20	98	78	15	12	25,5	10	60	33,3	40	50	31	12,7	M8	12160	6318	UC204	FA204	0,46
UCFA204-12	3/4	3 5/64	3 3/64	1 9/32	1 15/32	1	2 5/64	2 3/8	1 1/6	1 3/64	1 3 1/2	1,2205	0,500	5/16			UC204-12		0,46
UCFA205	25	124	98	16	14	27	13	70	35,8	51	65	34,1	14,3	M10			UC205		0,66
UCFA205-13	1 3/16																UC205-13		0,70
UCFA205-14	7/8	4 7/8	3 5 5/64	5/8	3 5/64	1 1/6	3 3/64	2 3/4	1 1 3/32	2 1/64	2 2/6	1,3425	0,563	3/8	13300	7457	UC205-14	FA205	0,69
UCFA205-15	1 5/16																UC205-15		0,67
UCFA205-16	1																UC205-16		0,66
UCFA206	30	141	115	18	14	31	13	83	40,2	58	72	38,1	15,9	M10			UC206		0,93
UCFA206-17	1 1/6																UC206-17		0,96
UCFA206-18	1 1/8	5 3 5/64	4 1 7/32	4 5/64	3 5/64	1 7/32	3 3/64	3 1 7/64	1 1 9/32	2 9/32	2 2 7/32	1,5000	0,626	3/8	18525	10735	UC206-18	FA206	0,95
UCFA206-19	1 3/16																UC206-19		0,93
UCFA206-20	1 1/4																UC206-20		0,92
UCFA207	35	155	128	19	16	34	15	96	44,4	66	82	42,9	17,5	M12			UC207		1,46
UCFA207-20	1 1/4																UC207-20		1,52
UCFA207-21	1 5/8	6 7/64	5 3/64	3/4	5/8	1 1 1/32	1 9/32	3 2 5/32	1 3/4	2 1 9/32	3 1 5/64	1,6890	0,689	7/16	24415	14630	UC207-21	FA207	1,49
UCFA207-22	1 3/8																UC207-22		1,46
UCFA207-23	1 7/16																UC207-23		1,43
UCFA208	40	171	142	21	16	38	15	105	51,2	71	87	49,2	19	M12			UC208		1,78
UCFA208-24	1 1/2	4 7/64	5 1 9/32	5 3/64	5/8	1 1/2	1 9/32	4 9/64	2 1/64	2 5 1/64	3 2 7/64	1,9370	0,748	7/16	27645	16910	UC208-24	FA208	1,82
UCFA208-25	1 9/16																UC208-25		1,79
UCFA209	45	179	146	22	18	40	17	111	52,2	72	90	49,2	19	M14			UC209		2,03
UCFA209-26	1 5/8																UC209-26		2,13
UCFA209-27	1 1 1/6	7 3/64	5 3/4	5 5/64	4 5/64	1 3 7/64	4 3/64	4 3/8	2 1/6	2 5 3/64	3 3 5/64	1,9370	0,748	1/2	32395	20235	UC209-27	FA209	2,09
UCFA209-28	1 3/4																UC209-28		2,05
UCFA210	50	189	155	22	18	40	17	116	54,6	76	94	51,6	19	M14			UC210		2,23
UCFA210-29	1 3 1/6																UC210-29		2,35
UCFA210-30	1 7/8	7 7/16	6 7/64	5 5/64	4 5/64	1 3 7/64	4 3/64	4 9/16	2 5/32	3	3 4 5/64	2,0315	0,748	1/2	33345	22135	UC210-30	FA210	2,30
UCFA210-31	1 1 5/16																UC210-31		2,25
UCFA210-32	2																UC210-32		2,21
UCFA211	55	216	182	25	20	44	17	133	58,4	86	104	55,6	22,2	M14			UC211		3,2
UCFA211-32	2																UC211-32		4,5
UCFA211-33	2 1/6	8 1/2	7 1 1/64	6 3/64	2 5/32	1 4 7/64	4 3/64	5 5 1/64	2 5/16	3 2 5/64	4 3 3/32	2,1890	0,874	1/2	41230	27930	UC211-33	FA211	4,20
UCFA211-34	2 1/8																UC211-34		4,10
UCFA211-35	2 3/16																UC211-35		4,00
UCFA212	60	240	202	29	20	48	19	140	68,7	100	118	65,1	25,4	M16			UC212		-
UCFA212-36	2 1/4																UC212-36		-
UCFA212-37	2 5/16	9 2 9/64	7 6 1/64	1 9/64	2 5/32	1 7/8	3/4	5 1/2	2 2 3/32	3 1 5/16	4 4 1/64	2,5630	1,000	5/8	49780	34390	UC212-37	FA212	-
UCFA212-38	2 3/8																UC212-38		-
UCFA212-39	2 7/16																UC212-39		-
UCFA213	65	250	210	30	20	50	19	155	69,7	102	122	65,1	25,4	M16			UC213		-
UCFA213-40	2 1/2	9 2 7/32	8 1 7/64	1 3/6	2 5/32	1 3 1/32	3/4	6 3/32	2 3/4	4 1/64	4 5 1/64	2,5630	1,000	5/8	54340	38095	UC213-40	FA213	-
UCFA213-41	2 9/16																UC213-41		-

Disponibile in acciaio inox Supporto: AISI 304 - Cuscinetto: AISI 440C o 420C - Available stainless steel Housing: AISI 304 - Bearing: AISI 440C or 420C
 Disponibile su richiesta con cuscinetto SA (SAFA) - Available under request with SA bearing (SAFA)

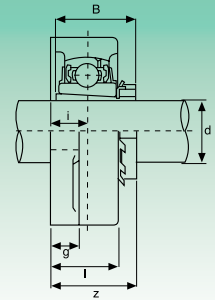
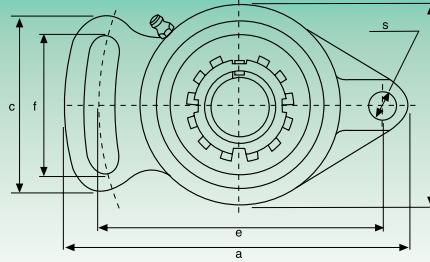
UKFA2 Serie normale - Standard duty

Tipo Type	Dimensioni - Dimensions												Bull. fiss. Bolt Size	Coefficienti di carico (N) Load ratings (N)		Cuscinetto Bearing	Supporto Housing	Peso Weight	
	d	a	e	i	g	l	s	b	z	f	c	B		Dinamico C Dynamic C	Statico C ₀ Static C ₀				kg
	mm/inch													mm/inch					
UKFA205+H2305	20	124	98	16	14	27	13	70	35,8	51	65	34,1	M10	13300	7457	UK205+H2305	FA205	0,71	
UKFA205+HE2305	3/4	4 7/8	3 5/8	5/8	3 5/8	1 1/16	3 3/8	2 3/4	1 13/32	2 1/4	2 9/16	1,3425	3/8			UK205+HE2305			
UKFA206+H2306	25	141	115	18	14	31	13	83	40,2	58	72	38,1	M10	18525	10735	UK206+H2306	FA206	1,04	
UKFA206+HS2306	7/8	5 35/64	4 17/32	4 9/64	3 5/64	1 7/32	3 3/64	3 17/64	1 19/32	2 9/32	2 27/32	1,5000	3/8			UK206+HS2306			
UKFA206+HE2306	1															UK206+HE2306			
UKFA207+H2307	30	155	128	19	16	34	15	96	44,4	66	82	42,9	M12	24415	14630	UK207+H2307	FA207	1,5	
UKFA207+HS2307	1 1/8	6 7/64	5 3/64	3/4	5/8	1 11/32	1 9/32	3 25/32	1 3/4	2 19/32	3 15/64	1,6890	7/16			UK207+HS2307			
UKFA208+H2308	35	171	142	21	16	38	15	105	51,2	71	87	49,2	M12	27645	16910	UK208+H2308	FA208	1,9	
UKFA208+HE2308	1 1/4	4 7/64	5 19/32	5 3/64	5/8	1 1/2	1 9/32	4 9/64	2 1/64	2 51/64	3 27/64	1,9370	7/16			UK208+HE2308			
UKFA208+HS2308	1 3/8															UK208+HS2308			
UKFA209+H2309	40	179	146	22	18	40	17	111	52,2	72	90	49,2	M14	32395	20235	UK209+H2309	FA209	1,8	
UKFA209+HA2309	1 7/16	7 3/64	5 3/4	5 5/64	4 5/64	1 37/64	4 3/64	4 3/8	2 1/16	2 53/64	3 35/64	1,9370	1/2			UK209+HA2309			
UKFA209+HE2309	1 1/2															UK209+HE2309			
UKFA209+HS2309	1 5/8															UK209+HS2309			
UKFA210+H2310	45	189	155	22	18	40	17	116	54,6	76	94	51,6	M14	33345	22135	UK210+H2310	FA210	2,1	
UKFA210+HS2310	1 5/8	7 1/16	6 7/64	5 5/64	4 5/64	1 37/64	4 3/64	4 9/16	2 5/32	3	3 45/64	2,0315	1/2			UK210+HS2310			
UKFA210+HA2310	1 11/16															UK210+HA2310			
UKFA210+HE2310	1 3/4															UK210+HE2310			

Bussole HA; HE; HS con filettatura in pollici
Inch dimension adapter sleeves HA; HE; HS

UCFB2 Serie normale - Standard duty

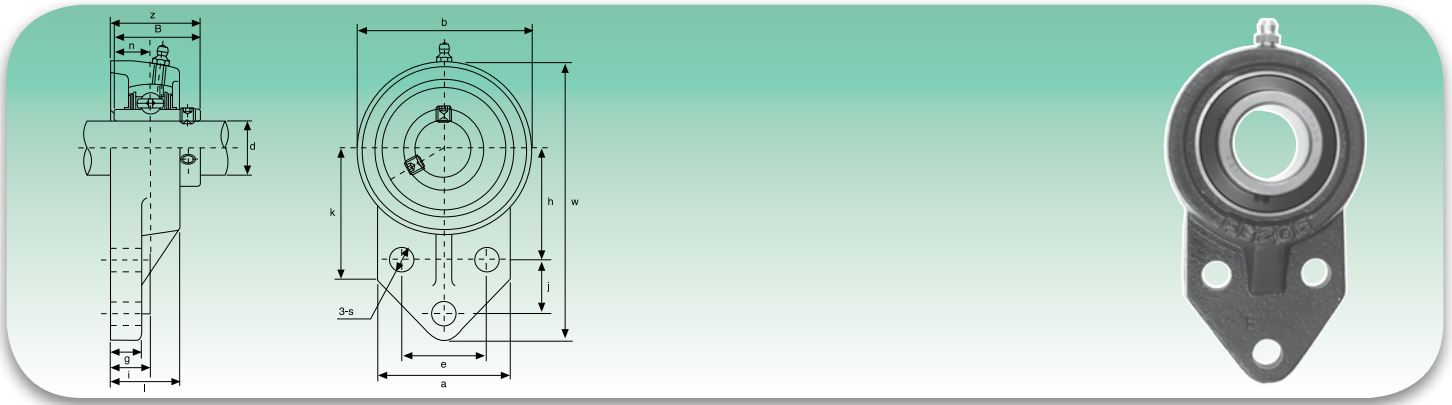

Tipo Type	Dimensioni - Dimensions														Bull. fiss. Bolt Size	Coefficients di carico (N) Load ratings (N)		Cuscinetto Bearing	Supporto Housing	Peso Weight	
	d	w	b	k	a	l	s	g	h	j	e	i	z	B		n	Dinamico C Dynamic C _d				Statico C _o Static C _o
	mm/inch															mm/inch					
UCFB201	12	110	62	52	52	25,5	10	13	42	27	32	15	33,3	31	12,7	M8	12160	6318	UC201	FB204	0,58
UCFB201-8	3/4	4 11/32	2 7/16	2 1/16	2 1/16	1	25/64	1/2	1 21/32	1 1/16	1 17/64	1 9/32	1 1/16	1,2205	0,500	5/16			UC201-8		0,57
UCFB202	15	110	62	52	52	25,5	10	13	42	27	32	15	33,3	31	12,7	M8	12160	6318	UC202	FB204	0,57
UCFB202-9	9/16	4 11/32	2 7/16	2 1/16	2 1/16	1	25/64	1/2	1 21/32	1 1/16	1 17/64	1 9/32	1 1/16	1,2205	0,500	5/16			UC202-9		0,57
UCFB202-10	5/8	4 11/32	2 7/16	2 1/16	2 1/16	1	25/64	1/2	1 21/32	1 1/16	1 17/64	1 9/32	1 1/16	1,2205	0,500	5/16			UC202-10		0,57
UCFB203	17	110	62	52	52	25,5	10	13	42	27	32	15	33,3	31	12,7	M8	12160	6318	UC203	FB204	0,56
UCFB203-11	1 1/16	4 11/32	2 7/16	2 1/16	2 1/16	1	25/64	1/2	1 21/32	1 1/16	1 17/64	1 9/32	1 1/16	1,2205	0,500	5/16			UC203-11		0,55
UCFB204	20	110	62	52	52	25,5	10	13	42	27	32	15	33,3	31	12,7	M8	12160	6318	UC204	FB204	0,54
UCFB204-12	3/4	4 11/32	2 7/16	2 1/16	2 1/16	1	25/64	1/2	1 21/32	1 1/16	1 17/64	1 9/32	1 1/16	1,2205	0,500	5/16			UC204-12		0,54
UCFB205	25	116	68	52	56	27	10	13	45	27	34	16	35,8	34,1	14,3	M8			UC205		0,79
UCFB205-13	1 3/16																		UC205-13		0,83
UCFB205-14	7/8																		UC205-14	FB205	0,82
UCFB205-15	1 5/16	4 9/16	2 11/16	2 1/16	2 7/32	1 1/16	25/64	1/2	1 49/64	1 1/16	1 11/32	5/8	1 13/32	1,3425	0,563	5/16	13300	7457	UC205-15		0,80
UCFB205-16	1																		UC205-16		0,79
UCFB206	30	130	78	55	65	31	10	13	50	29	40	18	40,2	38,1	15,9	M8			UC206		0,95
UCFB206-17	1 1/16																		UC206-17		0,98
UCFB206-18	1 1/8	5 1/8	3 1/16	2 9/32	2 9/16	1 1/32	25/64	1/2	1 31/32	1 9/64	1 37/64	45/64	1 19/32	1,5000	0,626	5/16	18525	10735	UC206-18	FB206	0,97
UCFB206-19	1 3/16																		UC206-19		0,95
UCFB206-20	1 1/4																		UC206-20		0,94
UCFB207	35	144	90	62	70	34	10	15	55	32	46	19	44,4	42,9	17,5	M8			UC207		1,29
UCFB207-20	1 1/4																		UC207-20		1,35
UCFB207-21	1 5/16	5 21/32	3 35/64	2 7/16	2 3/4	1 11/32	25/64	1 9/32	2 11/64	1 17/64	1 13/16	3/4	1 3/4	1,6890	0,689	5/16	24415	14630	UC207-21	FB207	1,32
UCFB207-22	1 3/8																		UC207-22		1,29
UCFB207-23	1 7/16																		UC207-23		1,26
UCFB208	40	164	100	72	78	36	12	16	60	41	50	21	51,2	49,2	19	M10			UC208		1,78
UCFB208-24	1 1/2	6 15/32	3 15/16	2 27/32	3 1/16	1 13/32	1 5/32	5/8	2 23/64	1 39/64	1 31/32	53/64	2 1/64	1,9370	0,748	3/8	27645	16910	UC208-24	FB208	1,82
UCFB208-25	1 9/16																		UC208-25		1,79
UCFB209	45	174	106	76	80	38	12	18	65	43	54	22	52,2	49,2	19	M10			UC209		1,91
UCFB209-26	1 5/8																		UC209-26		2,01
UCFB209-27	1 11/16	6 27/32	4 3/16	3	3 3/32	1 1/2	1 5/32	2 3/32	2 9/16	1 11/16	2 1/8	55/64	2 1/16	1,9370	0,748	3/8	32395	20235	UC209-27	FB209	1,97
UCFB209-28	1 3/4																		UC209-28		1,93
UCFB210	50	184	112	82	86	40	12	18	68	46	58	22	54,6	51,6	19	M10			UC210		2,36
UCFB210-29	1 3/4																		UC210-29		2,48
UCFB210-30	1 7/8	7 1/4	4 13/32	3 7/32	3 3/8	1 37/64	1 5/32	2 3/32	2 43/64	1 13/16	2 9/32	55/64	2 5/32	2,0315	0,748	3/8	33345	22135	UC210-30	FB210	2,43
UCFB210-31	1 15/16																		UC210-31		2,38
UCFA210-32	2																		UC210-32		2,34
UCFB211	55	207	130	86	90	43	14	18	78	50	62	25	58,4	55,6	22,2	M12			UC211		3,15
UCFB211-32	2																		UC211-32		3,31
UCFB211-33	2 1/16	8 5/32	5 1/8	3 25/64	3 35/64	1 11/16	35/64	45/64	3 3/64	1 31/32	2 7/16	63/64	2 1/16	2,1890	0,874	7/16	41230	27930	UC211-33	FB211	3,25
UCFB211-34	2 1/8																		UC211-34		3,20
UCFB211-35	2 3/16																		UC211-35		3,14
UCFB212	60	223	140	90	94	48	14	18	84	55	66	29	68,7	65,1	25,4	M12			UC212		3,99
UCFB212-36	2 1/4																		UC212-36		4,12
UCFB212-37	2 5/16	8 25/32	5 1/2	3 35/64	3 45/64	1 7/8	35/64	45/64	3 5/16	2 11/64	2 19/32	1 9/64	2 23/32	2,5630	1,000	7/16	49780	34390	UC212-37	FB212	4,04
UCFB212-38	2 3/8																		UC212-38		3,97
UCFB212-39	2 7/16																		UC212-39		3,90
UCFB213	65	244	155	94	100	50	14	20	92	60	70	30	69,7	65,1	25,4	M12			UC213		-
UCFB213-40	2 1/2	9 39/64	6 7/64	3 45/64	3 15/16	1 31/32	35/64	25/32	3 5/8	2 23/64	2 3/4	1 3/16	2 3/4	2,5630	1,000	7/16	54340	38095	UC213-40	FB213	-
UCFB213-41	2 9/16																		UC213-41		-

Disponibile in acciaio inox Supporto: AISI 304 - Cuscinetto: AISI 440C o 420C - Available stainless steel Housing: AISI 304 - Bearing: AISI 440C or 420C
 Disponibile su richiesta con cuscinetto SA (SAFB) - Available under request with SA bearing (SAFB)

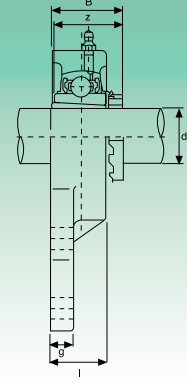
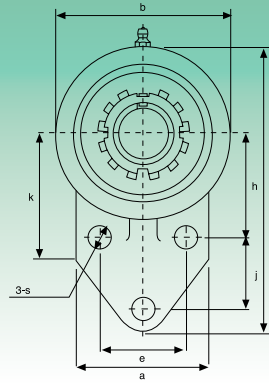
UKFB2 Serie normale - Standard duty

Tipo Type	Dimensioni - Dimensions														Bull. fiss. Bolt Size	Coefficienti di carico (N) Load ratings (N)		Cuscinetto Bearing	Supporto Housing	Peso Weight kg
	d	w	b	k	a	l	s	g	h	j	e	i	z	B		Dinamico C Dynamic C	Statico C ₀ Static C ₀			
	mm/inch															mm/inch				
UKFB205+H2305	20	116	68	52	56	27	10	13	45	27	34	16	35,8	34,1	M8	13300	7457	UK205+H2305	FB205	0,72
UKFB205+HE2305	¾	4½	2½	2¼	2½	1½	25/64	½	149/64	1¼	1½	5/8	1½	1,3425	5/16			UK205+HE2305		
UKFB206+H2306	25	130	78	55	65	31	10	13	50	29	40	18	40,2	38,1	M8	18525	10735	UK206+H2306	FB206	0,96
UKFB206+HS2306	¾	5½	3½	2½	2½	1½	25/64	½	131/32	1¾	137/64	45/64	1½	1,5000	5/16			UK206+HS2306		
UKFB206+HE2306	1														5/16			UK206+HE2306		
UKFB207+H2307	30	144	90	62	70	34	10	15	55	32	46	19	44,4	42,9	M8	24415	14630	UK207+H2307	FB207	1,33
UKFB207+HS2307	1½	52½	33¾	27/16	2¾	1½	25/64	19/32	211/64	1½	131/16	¾	1¾	1,6890	5/16			UK207+HS2307		
UKFB208+H2308	35	164	100	72	78	36	12	16	60	41	50	21	51,2	49,2	M10	27645	16910	UK208+H2308	FB208	1,82
UKFB208+HE2308	1¼	6½	3½	27/32	3¼	1½	15/32	5/8	223/32	139/64	131/32	53/64	2¼	1,9370	3/8			UK208+HE2308		
UKFB208+HS2308	1¾														3/8			UK208+HS2308		
UKFB209+H2309	40	174	106	76	80	38	12	18	65	43	54	22	52,2	49,2	M10	32395	20235	UK209+H2309	FB209	2,09
UKFB209+HA2309	17/16	627/32	4¾	3	35/32	1½	15/32	23/32	29/16	1½	2½	55/64	2¼	1,9370	3/8			UK209+HA2309		
UKFB209+HE2309	1½														3/8			UK209+HE2309		
UKFB209+HS2309	1¾														3/8			UK209+HS2309		
UKFB210+H2310	45	184	112	82	86	40	12	18	68	46	58	22	54,6	51,6	M10	33345	22135	UK210+H2310	FB210	2,39
UKFB210+HS2310	1¾	7¼	413/32	37/32	3¾	137/64	15/32	23/32	243/64	131/16	29/32	55/64	25/32	2,0315	3/8			UK210+HS2310		
UKFB210+HA2310	111/16														3/8			UK210+HA2310		
UKFB210+HE2310	1¾														3/8			UK210+HE2310		

Bussole HA; HE; HS con filettatura in pollici
Inch dimension adapter sleeves HA; HE; HS

UCECH2 Serie normale - Standard duty

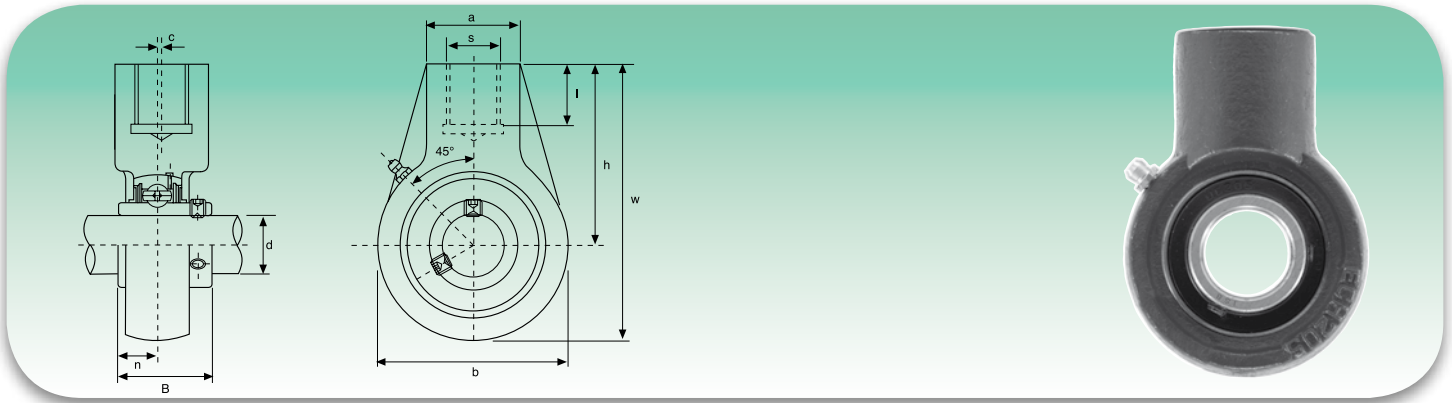

Tipo Type	Dimensioni - Dimensions										Coefficients di carico (N) Load ratings (N)		Cuscinetto Bearing	Supporto Housing	Peso Weight	
	d	h	w	b	c	a	l	B	n	S	Dinamico C Dynamic C	Statico C ₀ Static C ₀				kg
	mm/inch															
UCECH201	12	64	96	64	0	40	19	31	12,7		G _{3/4}	12160	6318	UC201	ECH204	0,73
UCECH201-8	3/4	2 ^{33/64}	3 ^{25/32}	2 ^{33/64}	0	1 ^{37/64}	3/4	1,2205	0,500					UC201-8		0,72
UCECH202	15	64	96	64	0	40	19	31	12,7		G _{3/4}	12160	6318	UC202	ECH204	0,72
UCECH202-9	9/16	2 ^{33/64}	3 ^{25/32}	2 ^{33/64}	0	1 ^{37/64}	3/4	1,2205	0,500					UC202-9		0,72
UCECH202-10	5/8													UC202-10		0,72
UCECH203	17	64	96	64	0	40	19	31	12,7		G _{3/4}	12160	6318	UC203	ECH204	0,71
UCECH203-11	1 ^{1/16}	2 ^{33/64}	3 ^{25/32}	2 ^{33/64}	0	1 ^{37/64}	3/4	1,2205	0,500					UC203-11		0,70
UCECH204	20	64	96	64	0	40	19	31	12,7		G _{3/4}	12160	6318	UC204	ECH204	0,69
UCECH204-12	3/4	2 ^{33/64}	3 ^{25/32}	2 ^{33/64}	0	1 ^{37/64}	3/4	1,2205	0,500					UC204-12		0,69
UCECH205	25	64	103	78	0	40	19	34,1	14,3					UC205		0,83
UCECH205-13	1 ^{3/16}													UC205-13		0,87
UCECH205-14	7/8													UC205-14		0,86
UCECH205-15	1 ^{5/16}	2 ^{33/64}	4 ^{1/16}	3 ^{5/64}	0	1 ^{37/64}	3/4	1,3425	0,563		G _{3/4}	13300	7457	UC205-15	ECH205	0,84
UCECH205-16	1													UC205-16		0,83
UCECH206	30	64	103	78	0	40	19	38,1	15,9					UC206		0,83
UCECH206-17	1 ^{1/16}													UC206-17		0,86
UCECH206-18	1 ^{1/8}													UC206-18	ECH206	0,85
UCECH206-19	1 ^{3/16}	2 ^{33/64}	4 ^{1/16}	3 ^{5/64}	0	1 ^{37/64}	3/4	1,5000	0,626		G _{3/4}	18525	10735	UC206-19		0,83
UCECH206-20	1 ^{1/4}													UC206-20		0,82
UCECH207	35	70	116	92	0	40	19	42,9	17,5					UC207		1,16
UCECH207-20	1 ^{1/4}													UC207-20		1,22
UCECH207-21	1 ^{5/16}													UC207-21	ECH207	1,19
UCECH207-22	1 ^{3/8}	2 ^{3/4}	4 ^{1/16}	3 ^{3/8}	0	1 ^{37/64}	3/4	1,6890	0,689		G _{3/4}	24415	14630	UC207-22		1,16
UCECH207-23	1 ^{7/16}													UC207-23		1,13
UCECH208	40	73	121	96	2	40	19	49,2	19					UC208		1,32
UCECH208-24	1 ^{1/2}													UC208-24	ECH208	1,36
UCECH208-25	1 ^{9/16}	2 ^{7/8}	4 ^{9/64}	3 ^{25/32}	5/64	1 ^{37/64}	3/4	1,9370	0,748		G _{3/4}	27645	16910	UC208-25		1,33
UCECH209	45	82	136	108	5	48	21	49,2	19					UC209		1,92
UCECH209-26	1 ^{5/8}													UC209-26	ECH209	2,02
UCECH209-27	1 ^{11/16}	3 ^{15/64}	5 ^{23/64}	4 ^{1/4}	1 ^{3/64}	1 ^{57/64}	5 ^{3/64}	1,9370	0,748		G ₁	32395	20235	UC209-27		1,98
UCECH209-28	1 ^{3/4}													UC209-28		1,94
UCECH210	50	83	142	118	5	48	21	51,6	19					UC210		1,90
UCECH210-29	1 ^{13/16}													UC210-29		2,02
UCECH210-30	1 ^{7/8}													UC210-30	ECH210	1,97
UCECH210-31	1 ^{15/16}	3 ^{17/64}	5 ^{19/32}	4 ^{41/64}	1 ^{3/64}	1 ^{57/64}	7 ^{7/8} 5 ^{3/64}	2,0315	0,748		G ₁	33345	22135	UC210-31		1,92
UCECH210-32	2													UC210-32		1,88
UCECH211	55	87	150	126	7	60	25	55,6	22,2					UC211		2,61
UCECH211-32	2													UC211-32		2,76
UCECH211-33	2 ^{1/16}													UC211-33	ECH211	2,70
UCECH211-34	2 ^{1/8}	3 ^{27/64}	5 ^{29/32}	4 ^{61/64}	9/32	2 ^{23/64}	6 ^{3/64}	2,1890	0,874		G _{1 1/4}	41230	27930	UC211-34		2,65
UCECH211-35	2 ^{3/16}													UC211-35		2,59
UCECH212	60	102	173	142	9	60	28	65,1	25,4					UC212		3,54
UCECH212-36	2 ^{1/4}													UC212-36	ECH212	3,67
UCECH212-37	2 ^{5/16}													UC212-37		3,59
UCECH212-38	2 ^{3/8}	4 ^{1/64}	6 ^{13/16}	5 ^{19/32}	2 ^{3/64}	2 ^{23/64}	1 ^{7/64}	2,5630	1,000		G _{1 1/4}	49780	34390	UC212-38		3,52
UCECH212-39	2 ^{7/16}													UC212-39		3,45
UCECH213	65	117	200	166	9,5	70	32	65,1	25,4					UC213		5,80
UCECH213-40	2 ^{1/2}													UC213-40	ECH213	5,89
UCECH213-41	2 ^{9/16}	4 ^{39/64}	7 ^{7/8}	6 ^{17/32}	3/8	2 ^{3/4}	1 ^{17/64}	2,5630	1,000		G _{1 1/2}	54340	38095	UC213-41		5,80
UCECH214	70	117	200	166	9,5	70	32	74,6	30,2					UC214		5,67
UCECH214-42	2 ^{5/8}													UC214-42	ECH214	5,67
UCECH214-43	2 ^{11/16}	4 ^{39/64}	7 ^{7/8}	6 ^{17/32}	3/8	2 ^{3/4}	1 ^{17/64}	2,9370	1,189		G _{1 1/2}	59090	41895	UC214-43		5,67
UCECH214-44	2 ^{3/4}													UC214-44		5,67
UCECH215	75	117	200	166	9,5	70	32	77,8	33,3					UC215		5,58
UCECH215-45	2 ^{13/16}													UC215-45	ECH215	5,58
UCECH215-46	2 ^{7/8}													UC215-46		5,58
UCECH215-47	2 ^{15/16}	4 ^{39/64}	7 ^{3/32}	6 ^{17/32}	3/8	2 ^{3/4}	1 ^{17/64}	3,0630	1,311		G _{1 1/2}	64030	45885	UC215-47		5,58
UCECH215-48	3													UC215-48		5,58

Disponibile in acciaio inox Supporto: AISI 304 - Cuscinetto: AISI 440C o 420C - Available stainless steel Housing: AISI 304 - Bearing: AISI 440C or 420C
 Disponibile su richiesta con cuscinetto SA (SAECH) - Available under request with SA bearing (SAECH)

S - Su richiesta disponibili con filetto metrico, in pollici e gas
 S - Under request available with metric, inches and gas thread

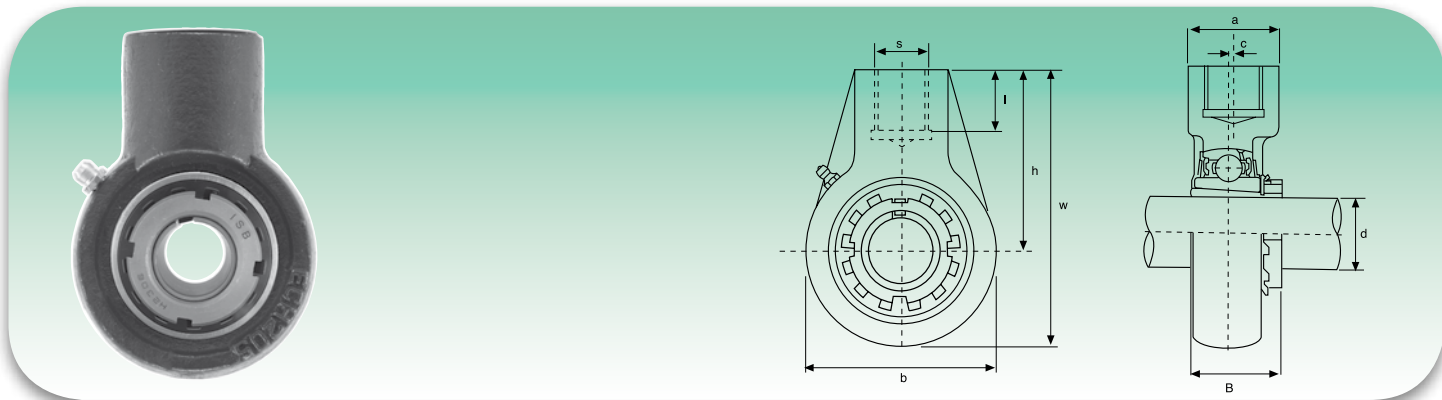
UKECH2 Serie normale - Standard duty

Tipo Type	Dimensioni - Dimensions									Coefficienti di carico (N) Load ratings (N)		Cuscinetto Bearing	Supporto Housing	Peso Weight kg
	d	h	w	b	c	a	l	B	S	Dinamico C Dynamic C	Statico C ₀ Static C ₀			
	mm/inch													
UKECH205+H2305	20	64	103	78	0	40	19	34,1				UK205+H2305	ECH205	0,9
UKECH205+HE2305	¾	2 ³³ / ₆₄	4 ¹ / ₁₆	3 ³ / ₆₄	0	1 ³⁷ / ₆₄	¾	1,3425	G¾	13300	7457	UK205+HE2305		
UKECH206+H2306	25	64	103	78	0	40	19	38,1				UK206+H2306	ECH206	0,9
UKECH206+HS2306	7/8	2 ³³ / ₆₄	4 ¹ / ₁₆	3 ³ / ₆₄	0	1 ³⁷ / ₆₄	¾	1,5000	G¾	18525	10735	UK206+HS2306		
UKECH206+HE2306	1											UK206+HE2306		
UKECH207+H2307	30	70	116	92	0	40	19	42,9				UK207+H2307	ECH207	1,23
UKECH207+HS2307	1½	2¾	4 ⁹ / ₁₆	3 ⁵ / ₈	0	1 ³⁷ / ₆₄	¾	1,6890	G¾	24415	14630	UK207+HS2307		
UKECH208+H2308	35	73	121	96	2	40	19	49,2				UK208+H2308	ECH208	1,32
UKECH208+HE2308	1¼	2 ⁷ / ₈	4 ⁹ / ₆₄	3 ²⁵ / ₃₂	5/64	1 ³⁷ / ₆₄	¾	1,9370	G¾	27645	16910	UK208+HE2308		
UKECH208+HS2308	1¾											UK208+HS2308		
UKECH209+H2309	40	82	136	108	5	48	21	49,2				UK209+H2309	ECH209	1,79
UKECH209+HA2309	1 ⁷ / ₁₆	3 ¹⁵ / ₆₄	5 ²³ / ₆₄	4 ¹ / ₄	1 ³ / ₆₄	1 ⁵⁷ / ₆₄	5 ³ / ₆₄	1,9370	G1	32395	20235	UK209+HA2309		
UKECH209+HE2309	1½											UK209+HE2309		
UKECH209+HS2309	1¾											UK209+HS2309		
UKECH210+H2310	45	83	142	118	5	48	21	51,6				UK210+H2310	ECH210	2,19
UKECH210+HS2310	1¾	3 ¹⁷ / ₆₄	5 ¹ / ₃₂	4 ⁴ / ₆₄	1 ³ / ₆₄	1 ⁵⁷ / ₆₄	5 ³ / ₆₄	2,0315	G1	33345	22135	UK210+HS2310		
UKECH210+HA2310	1 ¹¹ / ₁₆											UK210+HA2310		
UKECH210+HE2310	1¾											UK210+HE2310		
UKECH211+H2311	50	87	150	126	7	60	25	55,6				UK211+H2311	ECH211	2,84
UKECH211+HS2311	1¾	3 ²⁷ / ₆₄	5 ²⁹ / ₃₂	4 ⁶ / ₆₄	9/32	2 ²³ / ₆₄	6 ³ / ₆₄	2,1890	G1¼	41230	27930	UK211+HS2311		
UKECH211+HA2311	1 ¹⁵ / ₁₆											UK211+HA2311		
UKECH211+HE2311	2											UK211+HE2311		
UKECH212+H2312	55	102	173	142	9	60	28	65,1				UK212+H2312	ECH212	3,81
UKECH212+HS2312	2 ¹ / ₈	4 ¹ / ₆₄	6 ¹ / ₁₆	5 ¹⁹ / ₃₂	2 ³ / ₆₄	2 ²³ / ₆₄	1 ⁷ / ₆₄	2,5630	G1¼	49780	34390	UK212+HS2312		

Bussole HA; HE; HS con filettatura in pollici

Inch dimension adapter sleeves HA; HE; HS

S - Su richiesta disponibili con filetto metrico, in pollici e gas

S - Under request available with metric, inches and gas thread

UP Serie leggera - Light duty

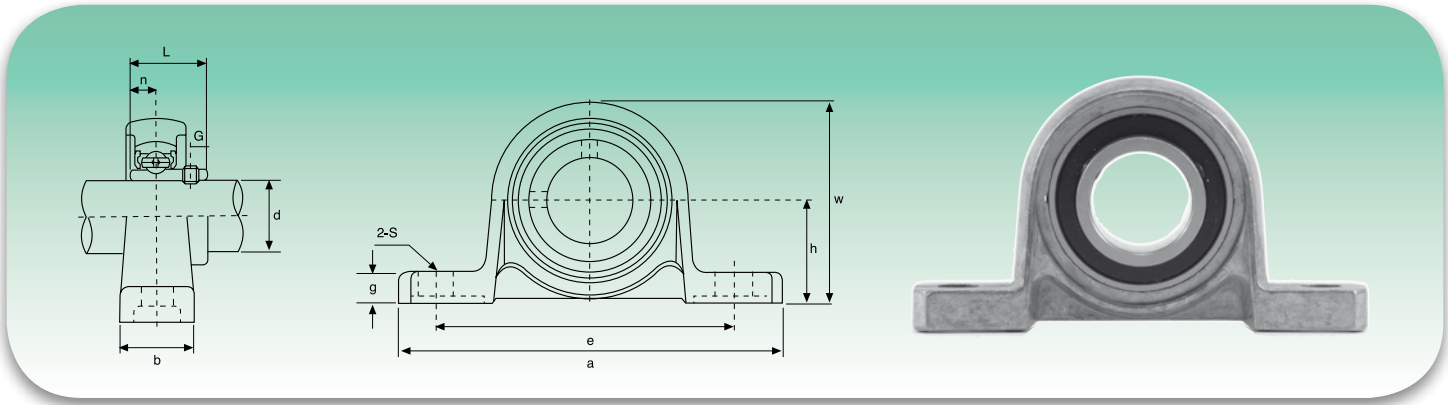

Tipo Type	Dimensioni - Dimensions											Bull. fiss. Bolt Size	Coefficients di carico (N) Load ratings (N)		Cuscinetto Bearing	Supporto Housing	Peso Weight kg
	d	h	a	e	b	s	g	w	L	n	G		Dinamico C Dynamic C	Statico C ₀ Static C ₀			
	mm/inch												mm/inch				
UP000	10	18	67	53	16	7	6	35	17,5	4	4	M6	4322	1852	U000	LP000	0,077
UP001	12	19	71	56	16	7	6	38	14,5	4	4	M6	4845	2280	U001	LP001	0,091
UP002	15	22	80	63	16	6	7	43	16,5	4,5	4	M6	5320	2707	U002	LP002	0,125
UP003	17	24	85	67	18	6	7	47	17,5	5	4	M6	5700	3087	U003	LP003	0,156
UP004	20	28	100	80	20	10	9	55	21	6	4,5	M8	8930	4797	U004	LP004	0,230
UP005	25	32	112	90	20	10	10	62	22,5	6	5	M8	9595	5557	U005	LP005	0,294
UP006	30	36	132	106	26	13	11	70	24,5	6,5	5	M10	12540	7837	U006	LP006	0,454
UP007	35	40	150	118	26	13	13	80	25,5	7	6	M10	14750	9750	U007	LP007	0,593

Disponibile su richiesta in acciaio inox supporto: AISI 304 - Cuscinetto: AISI 440C 0 420C - Available under request stainless steel housing: AISI 304 - Bearing: AISI 440C or 420C
 Su richiesta fornibili anche con anello di serraggio eccentrico - Under request available with eccentric collar locking

SUPPORTI A FLANGIA OVALE IN ALLUMINIO - ALUMINIUM OVAL BEARING UNITS

UFL Serie leggera - Light duty

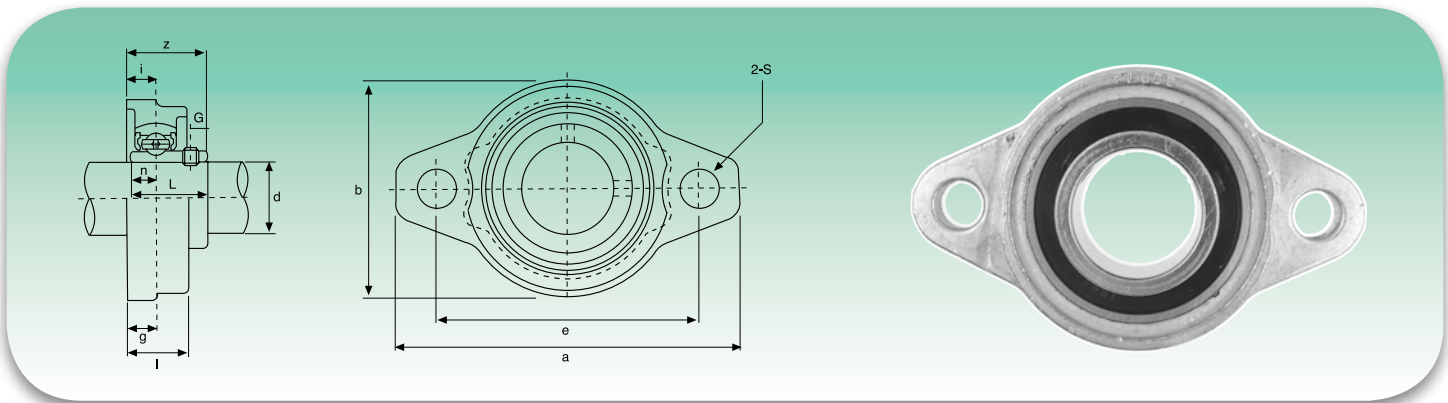

Tipo Type	Dimensioni - Dimensions											Bull. fiss. Bolt Size	Coefficients di carico (N) Load ratings (N)		Cuscinetto Bearing	Supporto Housing	Peso Weight kg	
	d	a	e	i	g	l	s	b	Z	L	n		G	Dinamico C Dynamic C				Statico C ₀ Static C ₀
	mm/inch												mm/inch					
UFL000	10	60	45	5,5	5,5	11,5	7	36	15,5	14	4	4	M6	4322	1852	U000	FL000	0,063
UFL001	12	63	48	5,5	5,5	11,5	7	38	19	14,5	4	4	M6	4845	2280	U001	FL001	0,076
UFL002	15	67	53	6,5	6,5	13	7	42	20,5	16,5	4,5	4	M6	5320	2707	U002	FL002	0,100
UFL003	17	71	56	7	7	14	7	46	22,5	17,5	5	4	M6	5700	3087	U003	FL003	0,129
UFL004	20	90	71	8	8	16	10	55	26,5	21	6	4,5	M8	8930	4797	U004	FL004	0,205
UFL005	25	95	75	8	8	16	10	60	27,5	22,5	6	5	M8	9595	5557	U005	FL005	0,244
UFL006	30	112	85	9	9	18	13	70	29,5	24,5	6,5	5	M10	12540	7837	U006	FL006	0,354
UFL007	35	122	95	10	10	20	13	80	32,5	27,5	7	6	M10	14750	9750	U007	FL007	0,498

Disponibile su richiesta in acciaio inox supporto: AISI 304 - Cuscinetto: AISI 440C 0 420C - Available under request stainless steel housing: AISI 304 - Bearing: AISI 440C or 420C
 Su richiesta fornibili anche con anello di serraggio eccentrico - Under request available with eccentric collar locking

Supporti in serie leggera in lega d'alluminio, fissaggio con grani. Un nuovo concetto di supporto; offre una significativa riduzione di peso ed ingombro rispetto alle normali serie, con risparmio economico nella progettazione di macchine.
 Extra light duty bearing units available with set screws, a totally new concept in bearing units, offer a significant reduction in size and weight when compared with the same size of existing series. This unique design promotes both space and material saving in machine tool and general equipment application.

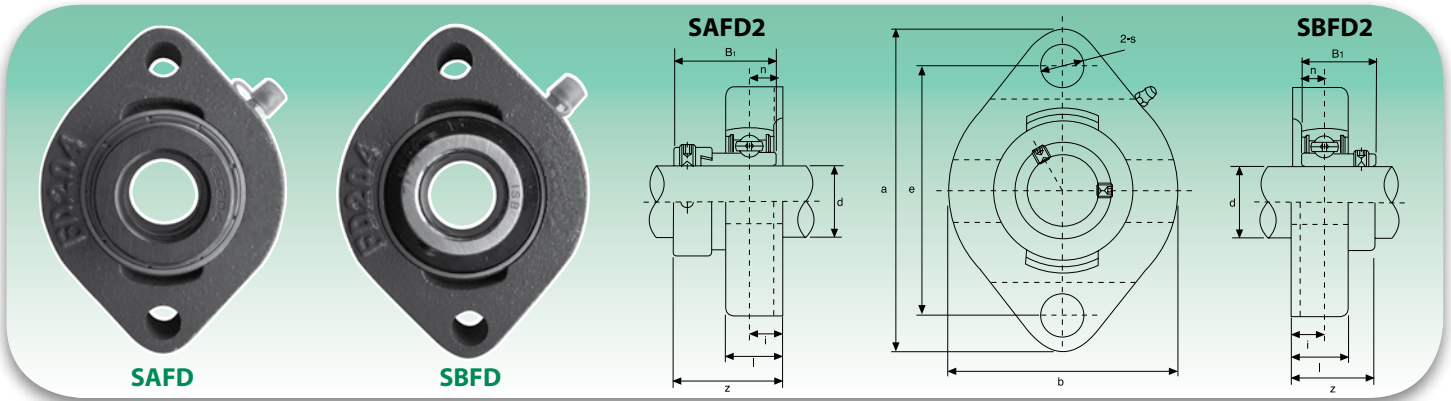
SAFD2 - SBFD2

Tipo Type	Dimensioni - Dimensions							Bull. fiss. Bolt Size	SAFD			Cuscinetto Bearing	Peso Weight	SBFD			Cuscinetto Bearing	Peso Weight	Supporto Housing	Coefficienti di carico (N) Load ratings (N)						
	d	a	e	b	i	s	l		z	B ₁	n			z	B ₁	n				Dinamico C Dynamic C	Statico C ₀ Static C ₀					
	mm/inch								mm/inch					mm/inch												
SAFD-SBFD																										
201	12	81	63	59	8,5	7	15	M6	30,6	28,6	6,5	SA201	0,3	24	22	6	SB201	0,3	FD203	9200	4480					
201-8	3/4	3 3/16	2 3/16	2 2/16	2 1/4	7/32	1 9/32	1/4	1 13/64	1,1260	0,2559	SA201-8		6 1/64	0,8661	0,2362	SB201-8									
SAFD-SBFD																										
202	15	81	63	59	8,5	7	15	M6	30,6	28,6	6,5	SA202	0,3	24	22	6	SB202	0,3	FD203	9200	4480					
202-9	5/16											SA202-9					SB202-9									
202-10	5/16	3 3/16	2 3/16	2 2/16	2 1/4	7/32	1 9/32	1/4	1 13/64	1,1260	0,2559	SA202-10		6 1/64	0,8661	0,2362	SB202-10									
SAFD-SBFD																										
203	17	81	63	59	8,5	7	15	M6	30,6	28,6	6,5	SA203	0,3	24	22	6	SB203	0,3	FD203	9200	4480					
203-11	1 1/16	3 3/16	2 3/16	2 2/16	2 1/4	7/32	1 9/32	1/4	1 13/64	1,1260	0,2559	SA203-11		6 1/64	0,8661	0,2362	SB203-11									
SAFD-SBFD																										
204	20	90	71	67	9,5	10	17	M8	33	31	7,5	SA204	0,5	27,5	25	7	SB204	0,4	FD204	12200	6300					
204-12	3/4	3 5/16	2 5/16	2 4/16	3/8	2 5/16	4 3/16	5/16	1 19/64	1,2204	0,2953	SA204-12		1 1/64	0,9843	0,2756	SB204-12									
SAFD-SBFD																										
205	25	95	76	71	9,5	10	17	M8	33	31	7,5	SA205	0,5	29	27	7,5	SB205	0,5	FD205	13300	7460					
205-13	1 3/16										SA205-13						SB205-13									
205-14	7/8	3 3/16	2 6/16	2 5/16	3/8	2 5/16	4 3/16	5/16	1 19/64	1,2204	0,2953	SA205-14			1 1/64	1,0630	0,2953					SB205-14				
205-15	1 5/16										SA205-15						SB205-15									
205-16	1										SA205-16						SB205-16									
SAFD-SBFD																										
206	30	113	90	84	12	12	21	M10	38,7	35,7	9	SA206	0,8	34	30	8	SB206	0,8	FD206	18500	10800					
206-17	1 1/16										SA206-17						SB206-17									
206-18	1 1/8	4 7/16	3 3/16	3 5/16	1 5/32	1 5/32	5 3/16	3/8	1 17/32	1,4055	0,3543	SA206-18			1 1 1/32	1,1811	0,3150					SB206-18				
206-19	1 3/16										SA206-19						SB206-19									
206-20	1 1/4										SA206-20						SB206-20									
SAFD-SBFD																										
207	35	125	100	94	12,5	12	22	M10	41,9	38,9	9,5	SA207	1,0	36	32	8,5	SB207	0,9	FD207	24500	14600					
207-20	1 1/4										SA207-20						SB207-20									
207-21	1 5/16	4 5 9/16	3 15/16	3 4 5/16	1/2	1 5/32	7/8	3/8	1 2 1/32	1,5315	0,3740	SA207-21			1 2 7/64	1,2598	0,3346					SB207-21				
207-22	1 3/8										SA207-22						SB207-22									
205-23	1 7/16										SA205-23						SB205-23									
SAFD-SBFD																										
208	40	149	119	104	15	14	25	M12	45,7	-	11	SA208	1,4	38	-	9	SA208	1,2	FD208	27700	17000					

SALF2 - SBLF2

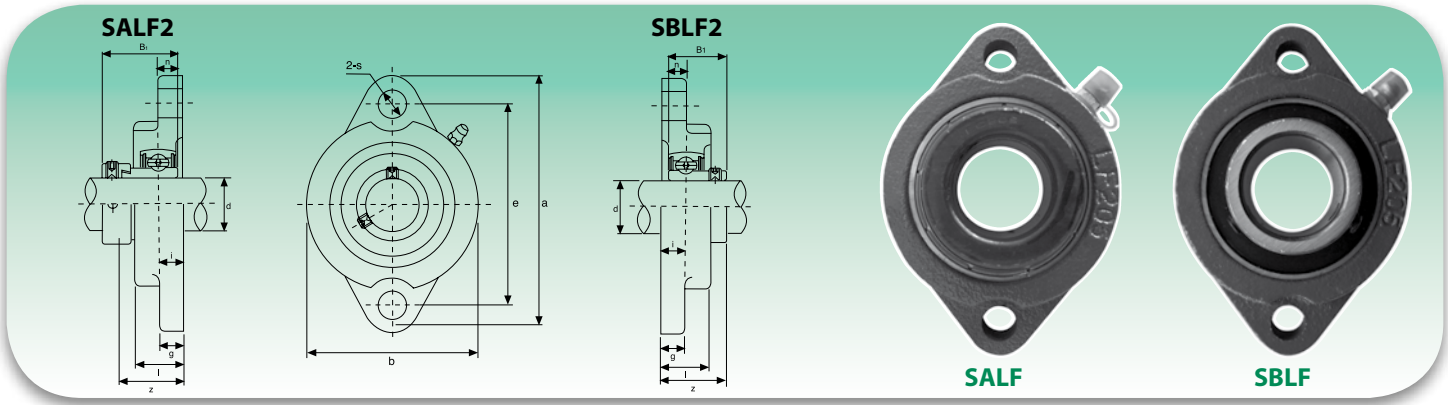

Tipo Type	Dimensioni - Dimensions								Bull. fiss. Bolt Size	SALF			Cuscinetto Bearing	Peso Weight	SBLF			Cuscinetto Bearing	Peso Weight	Supporto Housing	Coefficienti di carico (N) Load ratings (N)	
	d	a	e	b	i	s	g	l		z	B ₁	n			z	B ₁	n				Dinamico C Dynamic C	Statico C ₀ Static C ₀
	mm/inch									mm/inch					mm/inch							
SALF-SBLF 201 201-8	12 3/4	81 3 3/16	63,5 2 1/2	56 2 13/64	9,5 3/8	8 5/16	9,5 3/8	18 4 5/64	M6 1/4	31,6 1 1/4	28,6 1,1260	6,5 0,2559	SA201 SA201-8	0,3 1	25,5 0,8661	22 0,2362	6	SB201 SB201-8	0,3	LF203	9200	4480
SALF-SBLF 202 202-9 202-10	15 9/16 5/8	81 3 3/16	63,5 2 1/2	56 2 13/64	9,5 3/8	8 5/16	9,5 3/8	18 4 5/64	M6 1/4	31,6 1 1/4	28,6 1,1260	6,5 0,2559	SA202 SA202-9 SA202-10	0,3 1	25,5 0,8661	22 0,2362	6	SB202 SB202-9 SB202-10	0,3	LF203	9200	4480
SALF-SBLF 203 203-11	17 1 1/16	81 3 3/16	63,5 2 1/2	56 2 13/64	9,5 3/8	8 5/16	9,5 3/8	18 4 5/64	M6 1/4	31,6 1 1/4	28,6 1,1260	6,5 0,2559	SA203 SA203-11	0,3 1	25,5 0,8661	22 0,2362	6	SB203 SB203-11	0,3	LF203	9200	4480
SALF-SBLF 204 204-12	20 3/4	90 3 3/8	71,5 2 7/8	61 2 13/32	11 7/16	10 2 5/64	11 7/16	20 2 5/32	M8 5/16	34,5 1 23/64	31 1,2204	7,5 0,2953	SA204 SA204-12	0,4 1	29 0,9843	25 0,2756	7	SB204 SB204-12	0,3	LF204	12200	6300
SALF-SBLF 205 205-13 205-14 205-15 205-16	25 1 3/16 7/8 1 5/16 1	95 3 3/4	76 2 9/64	64 2 33/64	11 7/16	10 2 5/64	11 7/16	20 2 5/32	M8 5/16	34,5 1 23/64	31 1,2204	7,5 0,2953	SA205 SA205-13 SA205-14 SA205-15 SA205-16	0,5 1	30,5 1 13/64	27 1,0630	7,5 0,2953	SB205 SB205-13 SB205-14 SB205-15 SB205-16	0,4	LF205	13300	7460
SALF-SBLF 206 206-17 206-18 206-19 205-20	30 1 1/16 1 1/8 1 3/16 1 1/4	113 4 1/16	90,5 3 9/16	76 3	12 1 5/32	12 1 5/32	12 1 5/32	22,5 2 7/64	M10 3/8	38,7 1 33/64	35,7 1,4055	9 0,3543	SA206 SA206-17 SA206-18 SA206-19 SA206-20	0,7 1	34 1 1/32	30 1,1811	8 0,3150	SB206 SB206-17 SB206-18 SB206-19 SB206-20	0,6	LF206	18500	10800
SALF-SBLF 207 207-20 207-21 207-22 205-23	35 1 1/4 1 5/16 1 3/8 1 7/16	122 4 13/16	100 3 19/64	89 3 1/2	13 3 3/64	12 1 5/32	13 3 3/64	24 2 1/64	M10 3/8	42,4 1 43/64	38,9 1,5315	9,5 0,3740	SA207 SA207-20 SA207-21 SA207-22 SA207-23	0,9 1	36,5 1 7/16	32 1,2598	8,5 0,3346	SB207 SB207-20 SB207-21 SB207-22 SB207-23	0,8	LF207	24500	14600

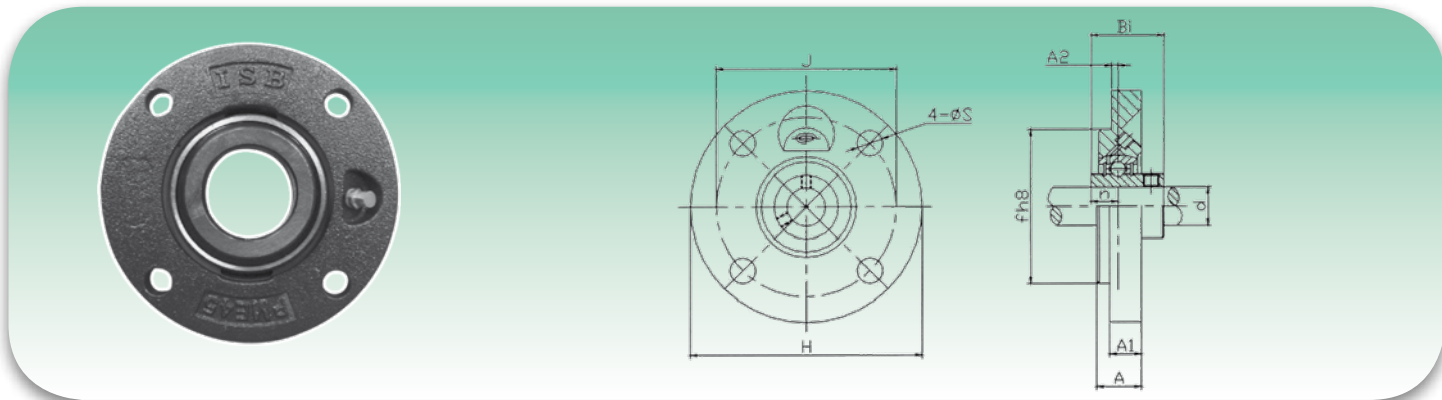

d Ø	Dimensioni - Dimensions							Viti fissaggio Fixing bolts	Tipo cuscinetto Bearing type	Peso fusione kg Housing weight kg
	H	J	A2	A1	A	S	f h8			
	mm									
20	100	78	2	8	17	9	62	M8	GRAE 20	0,37
25	115	90	2,5	9	19	9	70	M8	GRAE 25	0,55
30	125	100	2	9,5	20,5	11,5	80	M10	GRAE 30	0,66
35	135	110	1	10	20,5	11,5	90	M10	GRAE 35	0,79
40	145	120	1	11,5	23	11,5	100	M10	GRAE 40	1
45	155	130	2	12	25	14	105	M12	GRAE 45	1,24
50	165	135	1	13	25	14	110	M12	GRAE 50	1,53
55	185	150	0	15	27,5	18	125	M16	GRAE 55	1,95
60	195	160	1	16	29	18	135	M16	GRAE 60	2,15

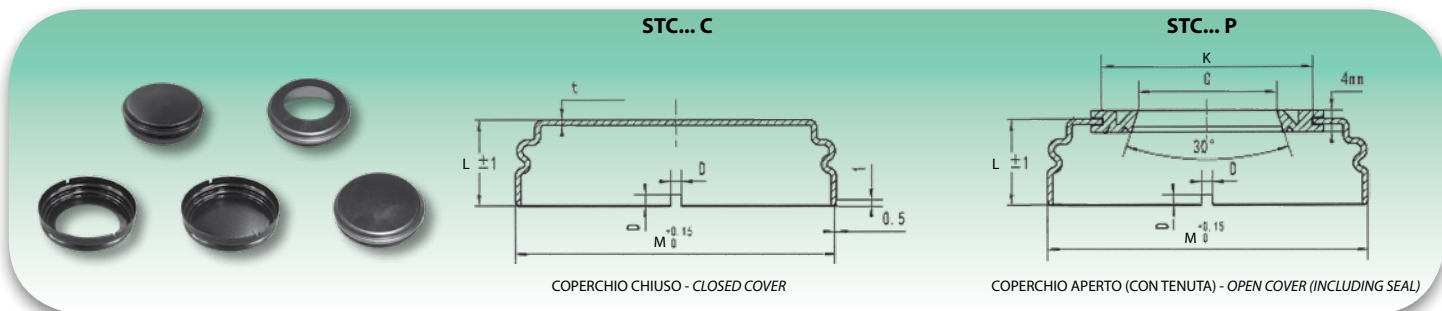

Tipo Type	Dimensioni - Dimensions					
	C	M	K	L	D	t
	mm					
STC204C	20	52	32	14,7	2,0	1,0
STC204P						
STC205C	25	58	38	15,5	2,0	1,0
STC205P						
STC206C	30	68	42	16,5	2,0	1,0
STC206P						
STC207C	35	78	48	19,5	2,5	1,0
STC207P						
STC208C	40	85,9	52	23,6	2,5	1,0
STC208P						
STC209C	45	91	57	24	2,5	1,0
STC209P						
STC210C	50	96	62	26	2,5	1,0
STC210P						
STC211C	55	108	67	25,5	2,5	1,0
STC211P						
STC212C	60	120	72	31,5	2,5	1,0
STC212P						
STC218C	90	168	102	40	2,5	1,0
STC218P						

I coperchi sono disponibili su richiesta - Covers are available under request

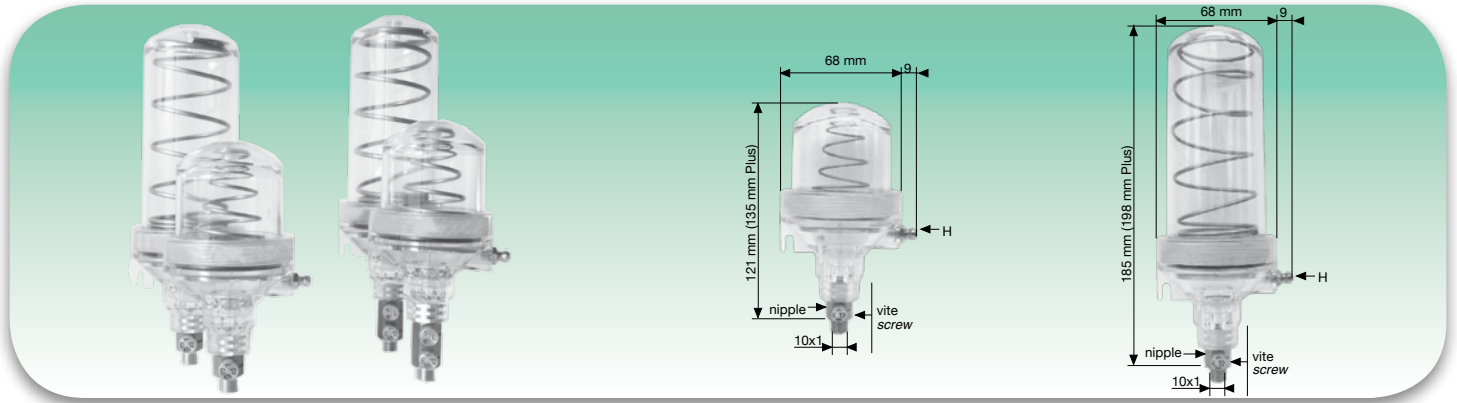

Gli ingrassatori e oliatori ISB sono costruiti in Lexan® trasparente, un materiale plastico ad alta resistenza meccanica, chimica e termica; questa soluzione permette di visualizzare il consumo del lubrificante in qualsiasi momento. All'interno delle capsule in Lexan® è presente una molla che permette di attivare immediatamente gli ingrassatori e oliatori ISB, che non necessitano quindi di energia elettrica o gas per funzionare; il flusso di lubrificante è sempre costante, senza accumuli solidi, ottenendo così un forte risparmio in termini di fermi di produzione ed eventuali riparazioni. Gli ingrassatori e gli oliatori ISB possono essere ricaricati più volte tramite l'ingrassatore laterale H (su richiesta disponibile in versione DE); essi sono installabili ovunque ci sia un punto da lubrificare (cuscinetti, boccole, snodi ecc).

The ISB greasers and oilers are made of transparent Lexan®, a plastic material with high mechanical, chemical and thermal resistance; this solution allows to control the consumption of the lubricant at any time. Inside the Lexan® capsules there is a spring that allows an immediate activation of the ISB greasers and oilers, so they do not need any electrical energy or gas to operate; the lubricant flow remains constant, with no solid matter accumulation and consequently there is an high saving in terms of production stops and possible repairs. The ISB greasers and oilers can be refilled more times from side lubricator H (under request the DE side lubricator is available); they can be installed wherever a point to be lubricated is present (bearings, bushes, joints etc).

Caratteristiche tecniche - Technical characteristics

Tipo Type	Capacità Capacity	Temperatura di utilizzo Temperature of application	Durata erogazione lubrificante Lubricant supply duration	Intensità fuoriuscita lubrificante Lubricant emission intensity	Molla Spring	Consistenza lubrificante Lubricant consistency
	ml	°C	mesi months			
INGRASSATORE ISB ISB GREASER	100/220	-30/+132	1,3,6,12	...	*D,M,F	NLGI 0-1-2-3-4
OLIATORE ISB ISB OILER	100/220	-30/+132	1,3,6,12	...	*D,M,F	NLGI 0-1-2-3-4
INGRASSATORE ISB PLUS ISB GREASER PLUS	100/220	-30/+132	1,3,6,12	**L,M,H	Unica	NLGI 0-1-2-3-4

* M: Molla media standard - Standard medium spring.

D: Molla debole per alta temperatura e/o grasso fluido (disponibile su richiesta) - Light spring for high temperature and/or fluid grease (available under request).

F: Molla forte per bassa temperatura e/o grasso denso (disponibile su richiesta) - Strong spring for low temperature and/or dense grease (available under request).

** L: Leggera - Light

M: Media - Medium

H: Alta - High



ADATTATORI (disponibili su richiesta)
ADAPTERS (available under request)



ESEMPIO DI APPLICAZIONE
APPLICATION EXAMPLE

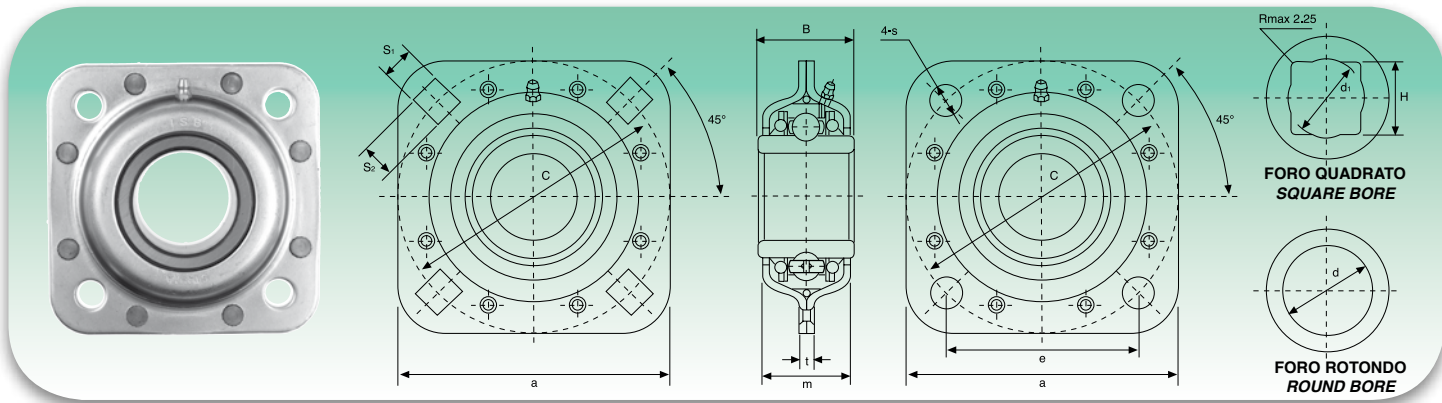

Tipo Type	Dimensioni - Dimensions												Coefficienti di carico (N) Load ratings (N)	
	H	d	a	B	m	t	C	s	s ₁	s ₂	d ₁	e	Dinamico C Dynamic C	Statico C ₀ Static C ₀
	mm/inch													
ST209-1½	29,972	-	127	42,8	42	6	127	13,5	13,5	17,45	32,0	-	24360	17710
ST209-30S	31,353	-	127	42,8	42	6	127	13,5	13,5	17,45	34,5	-	24360	17710
ST209-1¼	32,766	-	127	42,8	42	6	127	13,5	13,5	17,45	34,5	-	24360	17710
ST491B	-	38,860	127	42,8	42	6	127	13,5	13,5	17,45	-	-	24360	17710
ST209-40R	-	40,878	127	42,8	42	6	127	13,5	13,5	17,45	-	-	24360	17710
ST491A	-	45,000	127	42,8	42	6	127	13,5	13,5	17,45	-	90	24360	17710
ST209-45R	-	45,340	127	42,8	42	6	127	13,5	13,5	17,45	-	-	24360	17710
ST491A¹⁾	-	45,000	121	46	42	6	121	13,5	-	-	-	85	24360	17710
ST211-1½	38,890	-	139,7	50,8	46	8	139,7	13,5	13,5	17,45	42,0	-	33370	25110
ST211-40S	40,878	-	139,7	50,8	46	8	139,7	13,5	13,5	17,45	43,1	-	33370	25110
ST211-50R	-	50,400	139,7	50,8	46	8	139,7	13,5	13,5	17,45	-	-	33370	25110
ST211-55R	-	55,575	139,7	50,8	46	8	139,7	13,5	13,5	17,45	-	-	33370	25110
ST211-1¾	-	45,212	139,7	55,6	46	8	139,7	13,5	13,5	17,45	-	-	33370	25110
ST211-2¾/16	-	55,575	139,7	55,6	46	8	139,7	13,5	13,5	17,45	-	-	33370	25110
ST211-1¹⁵/₁₆	-	49,238	139,7	69,9	46	8	139,7	13,5	13,5	17,45	-	-	33370	25110
ST211	-	55,000	139,7	55,6	46	8	139,7	13,5	13,5	17,45	-	-	33370	25110
ST740	-	55,562	139,7	55,6	45	7	139,7	13,5	13,5	17,45	-	98	33370	25110

¹⁾ Dimensioni speciali - Special dimensions

Disponibile su richiesta con fori di fissaggio quadrati - Available on request with square fixing holes

BPP2-SA - BPP2-SB Serie leggera - Light duty

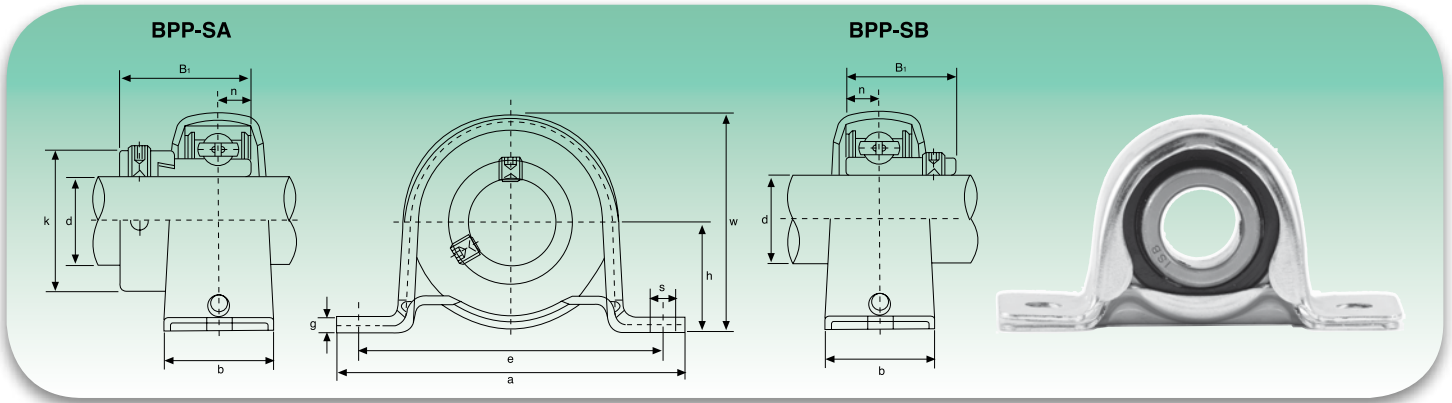

Tipo Type	Dimensioni - Dimensions								Bull. fiss. Bolt Size	BPP-SA		Cuscinetto Bearing	Peso Weight	BPP-SB		Cuscinetto Bearing	Peso Weight	Supporto Housing	Coefficienti di carico (N) Load ratings (N)	
	d	h	a	e	b	s	g	w		B ₁	n			B ₁	n				Dinamico C Dynamic C	Statico C ₀ Static C ₀
	mm/inch									mm/inch				mm/inch						
BPP-SA BPP-SB																				
201	12	22,2	86	68	25	9,5	3,2	43,8	M8	28,6	6,5	SA201	0,19	22	6	SB201	0,19	PP203	9200	4480
201-8	3/4	7/8	3 3/8	2 3/4	1 3/4	3/8	1/8	1 7/8	5/16	1,1260	0,2559	SA201-8		0,8661	0,2362	SB201-8				
BPP-SA BPP-SB																				
202	15	22,2	86	68	25	9,5	3,2	43,8	M8	28,6	6,5	SA202	0,19	22	6	SB202	0,19	PP203	9200	4480
202-9	5/8	7/8	3 3/8	2 3/4	1 3/4	3/8	1/8	1 7/8	5/16	1,1260	0,2559	SA202-9		0,8661	0,2362	SB202-9				
202-10	5/8	7/8	3 3/8	2 3/4	1 3/4	3/8	1/8	1 7/8	5/16	1,1260	0,2559	SA202-10		0,8661	0,2362	SB202-10				
BPP-SA BPP-SB																				
203	17	22,2	86	68	25	9,5	3,2	43,8	M8	28,6	6,5	SA203	0,19	22	6	SB203	0,19	PP203	9200	4480
203-11	1 1/8	7/8	3 3/8	2 3/4	1 3/4	3/8	1/8	1 7/8	5/16	1,1260	0,2559	SA203-11		0,8661	0,2362	SB203-11				
BPP-SA BPP-SB																				
204	20	25,4	98	76	32	9,5	3,2	50,6	M8	31	7,5	SA204	0,23	25	7	SB204	0,23	PP204	12200	6300
204-12	3/4	1	3 7/8	2 5/8	1 1/4	3/8	1/8	1 9/8	5/16	1,2204	0,2953	SA204-12		0,9843	0,2756	SB204-12				
BPP-SA BPP-SB																				
205	25	28,6	108	86	32	11,5	4	56,6	M10	31	7,5	SA205	0,32	27	7,5	SB205	0,28	PP205	13300	7460
205-13	1 3/8	1 1/8	4 1/4	3 1/4	1 1/4	2 1/8	1/4	2 1/8	3/8	1,2204	0,2953	SA205-13		1,0630	0,2953	SB205-13				
205-14	7/8	1 1/8	4 1/4	3 1/4	1 1/4	2 1/8	1/4	2 1/8	3/8	1,2204	0,2953	SA205-14		1,0630	0,2953	SB205-14				
205-15	1 5/16	1 1/8	4 1/4	3 1/4	1 1/4	2 1/8	1/4	2 1/8	3/8	1,2204	0,2953	SA205-15		1,0630	0,2953	SB205-15				
205-16	1	1 1/8	4 1/4	3 1/4	1 1/4	2 1/8	1/4	2 1/8	3/8	1,2204	0,2953	SA205-16		1,0630	0,2953	SB205-16				
BPP-SA BPP-SB																				
206	30	33,3	117	95	38	11,5	4	66,3	M10	35,7	9	SA206	0,50	30	8	SB206	0,47	PP206	18500	10800
206-17	1 1/8	1 1/8	4 3/8	3 3/4	1 1/2	2 1/8	1/4	2 3/8	3/8	1,4055	0,3543	SA206-17		1,1811	0,3150	SB206-17				
206-18	1 1/8	1 1/8	4 3/8	3 3/4	1 1/2	2 1/8	1/4	2 3/8	3/8	1,4055	0,3543	SA206-18		1,1811	0,3150	SB206-18				
206-19	1 3/8	1 1/8	4 3/8	3 3/4	1 1/2	2 1/8	1/4	2 3/8	3/8	1,4055	0,3543	SA206-19		1,1811	0,3150	SB206-19				
206-20	1 1/4	1 1/8	4 3/8	3 3/4	1 1/2	2 1/8	1/4	2 3/8	3/8	1,4055	0,3543	SA206-20		1,1811	0,3150	SB206-20				
BPP-SA BPP-SB																				
207	35	39,7	129	106	42	11,5	4,6	78	M10	38,9	9,5	SA207	0,71	32	8,5	SB207	0,57	PP207	24500	14600
207-20	1 1/4	1 3/8	5 1/4	4 1/2	1 3/4	2 3/8	1/4	3 1/8	3/8	1,5315	0,3740	SA207-20		1,2598	0,3346	SB207-20				
207-21	1 3/8	1 3/8	5 1/4	4 1/2	1 3/4	2 3/8	1/4	3 1/8	3/8	1,5315	0,3740	SA207-21		1,2598	0,3346	SB207-21				
207-22	1 3/8	1 3/8	5 1/4	4 1/2	1 3/4	2 3/8	1/4	3 1/8	3/8	1,5315	0,3740	SA207-22		1,2598	0,3346	SB207-22				
207-23	1 3/8	1 3/8	5 1/4	4 1/2	1 3/4	2 3/8	1/4	3 1/8	3/8	1,5315	0,3740	SA207-23		1,2598	0,3346	SB207-23				
BPP-SA BPP-SB																				
208	40	43,7	148	120	43	12	5	86,5	M10	43,7	11	SA208	0,95	34	9	SB208	0,80	PP208	27700	17000
208-24	1 1/2	1,721	5 13/16	4 11/16	1 11/16	3 3/4	1/4	3 3/4	3/8	1,721	0,4331	SA208-24		1,3386	0,3543	SB208-24				
208-25	1 1/2	1,721	5 13/16	4 11/16	1 11/16	3 3/4	1/4	3 3/4	3/8	1,721	0,4331	SA208-25		1,3386	0,3543	SB208-25				

Disponibile in acciaio inox Supporto: AISI 304 - Cuscinetto: AISI 440C o 420C - Available stainless steel Housing: AISI 304 - Bearing: AISI 440C or 420C

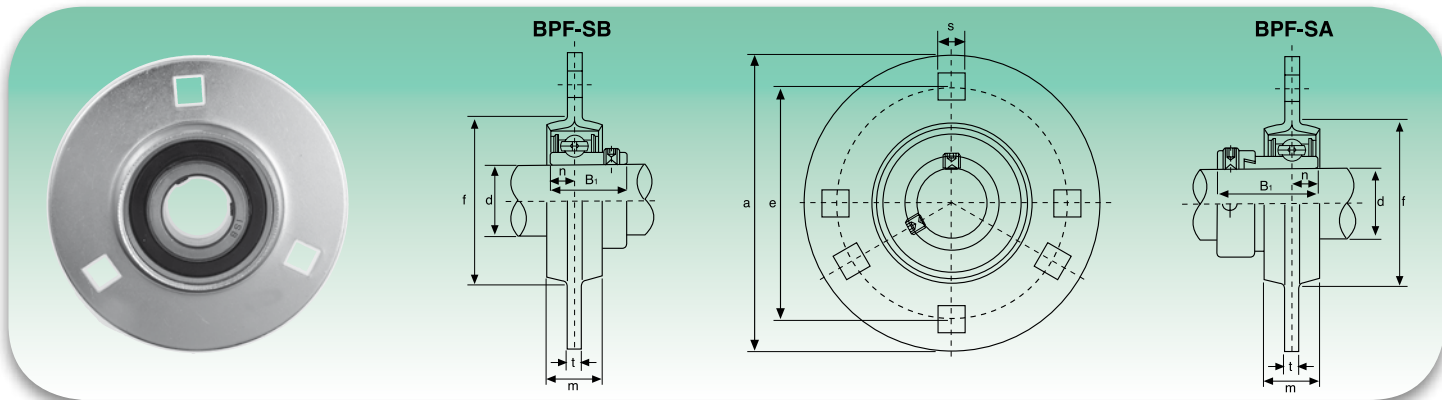

Tipo Type	Dimensioni - Dimensions							Bull. fiss. Bolt Size	BPF-SA		Cuscinetto Bearing	Peso Weight	BPF-SB		Cuscinetto Bearing	Peso Weight	Supporto Housing	Coefficienti di carico (N) Load ratings (N)	
	d	a	e	m	s	t	f(min)		B ₁	n			B ₁	n				Dinamico C Dynamic C	Statico C ₀ Static C ₀
	mm/inch								mm/inch				mm/inch						
BPF-SA BPF-SB 201 201-8	12 3/4	81 3 3/16	63,5 2 1/2	14 5/8	7,1 7/32	4 0,157	49 1 59/64	M6 1/4	28,6 1,1260	6,5 0,2559	SA201 SA201-8	0,3	22 0,8661	6 0,2362	SB201 SB201-8	0,27	PF203	9200	4480
BPF-SA BPF-SB 202 202-9 202-10	15 5/8 5/8	81 3 3/16	63,5 2 1/2	14 5/8	7,1 7/32	4 0,157	49 1 59/64	M6 1/4	28,6 1,1260	6,5 0,2559	SA202 SA202-9 SA202-10	0,3	22 0,8661	6 0,2362	SB202 SB202-9 SB202-10	0,27	PF203	9200	4480
BPF-SA BPF-SB 203 203-11	17 1 1/16	81 3 3/16	63,5 2 1/2	14 5/8	7,1 7/32	4 0,157	49 1 59/64	M6 1/4	28,6 1,1260	6,5 0,2559	SA203 SA203-11	0,3	22 0,8661	6 0,2362	SB203 SB203-11	0,27	PF203	9200	4480
BPF-SA BPF-SB 204 204-12	20 3/4	90 3 35/64	71,5 2 13/16	16 5/8	9 23/64	4 0,157	56 2 13/64	M8 5/16	31 1,2204	7,5 0,2953	SA204 SA204-12	0,33	25 0,9843	7 0,2756	SB204 SB204-12	0,33	PF204	12200	6300
BPF-SA BPF-SB 205 205-13 205-14 205-15 205-16	25 1 3/16 7/8 1 1/16 1	95 3 3/4	76 2 53/64	18 23/32	9 7/16	4 0,157	60 2 23/64	M8 5/16	31 1,2204	7,5 0,2953	SA205 SA205-13 SA205-14 SA205-15 SA205-16	0,42	27 1,0630	7,5 0,2953	SB205 SB205-13 SB205-14 SB205-15 SB205-16	0,38	PF205	13300	7460
BPF-SA BPF-SB 206 206-17 206-18 206-19 206-20	30 1 1/16 1 1/8 1 3/16 1 1/4	113 4 7/16	90,5 3 9/16	18 23/32	11 7/16	5,2 0,205	71 2 51/64	M10 3/8	35,7 1,4055	9 0,3543	SA206 SA206-17 SA206-18 SA206-19 SA206-20	0,65	30 1,1811	8 0,3150	SB206 SB206-17 SB206-18 SB206-19 SB206-20	0,62	PF206	18500	10800
BPF-SA BPF-SB 207 207-20 207-21 207-22 207-23	35 1 1/4 1 3/16 1 3/8 1 7/16	122 4 13/16	100 3 15/16	20 25/32	11 7/16	5,2 0,205	81 3 3/16	M10 3/8	38,9 1,5315	9,5 0,3740	SA207 SA207-20 SA207-21 SA207-22 SA207-23	0,9	32 1,2598	8,5 0,3346	SB207 SB207-20 SB207-21 SB207-22 SB207-23	0,82	PF207	24500	14600
BPF-SA BPF-SB 208 208-24 208-25	40 1 1/2 1 9/16	148 5 13/16	119 4 11/16	21 13/16	13,5 17/32	6,8 0,268	91 3 37/64	M12 1/2	43,7 1,7205	11 0,4331	SA208 SA208-24 SA208-25	1,15	34 1,3386	9 0,3543	SB208 SB208-24 SB208-25	1,1	PF208	27700	17000

Disponibile in acciaio inox Supporto: AISI 304 - Cuscinetto: AISI 440C o 420C - Available stainless steel Housing: AISI 304 - Bearing: AISI 440C or 420C.

BPFL2-SA - BPFL2-SB Serie leggera - Light duty

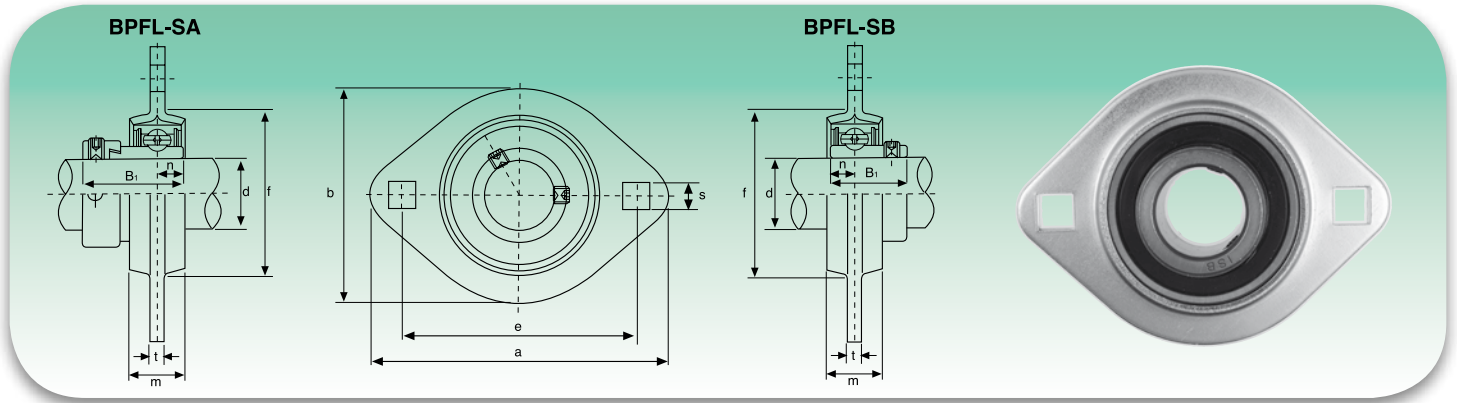

Tipo Type	Dimensioni - Dimensions								Bull. fiss. Bolt Size	BPFL-SA		Cuscinetto Bearing	Peso Weight	BPFL-SB		Cuscinetto Bearing	Peso Weight	Supporto Housing	Coefficienti di carico (N) Load ratings (N)	
	d	a	e	b	m	s	t	f (min)		B ₁	n			B ₁	n				Dinamico C Dynamic C	Statico C ₀ Static C ₀
	mm/inch									mm/inch				mm/inch					kg	
BPFL-SA BPFL-SB 201	12	81	63,5	59	14	7,1	4	49	M6	28,6	6,5	SA201	0,22	22	6	SB201	0,19	PFL203	9200	4480
201-8	3/4	3 3/16	2 1/2	2 3/64	9/16	1 59/64	0,157	1 59/64	1/4	1,1260	0,2559	SA201-8		0,8661	0,2362	SB201-8				
BPFL-SA BPFL-SB 202	15	81	63,5	59	14	7,1	4	49	M6	28,6	6,5	SA202	0,22	22	6	SB202	0,19	PFL203	9200	4480
202-9	9/16	3 3/16	2 1/2	2 3/64	9/16	1 59/64	0,157	1 59/64	1/4	1,1260	0,2559	SA202-9		0,8661	0,2362	SB202-9				
202-10	5/8											SA202-10				SB202-10				
BPFL-SA BPFL-SB 203	17	81	63,5	59	14	7,1	4	49	M6	28,6	6,5	SA203	0,22	22	6	SB203	0,19	PFL203	9200	4480
203-11	1 1/16	3 3/16	2 1/2	2 3/64	9/16	1 59/64	0,157	1 59/64	1/4	1,1260	0,2559	SA203-11		0,8661	0,2362	SB203-11				
BPFL-SA BPFL-SB 204	20	90	71,5	67	16	9	4	56	M8	31	7,5	SA204	0,24	25	7	SB204	0,24	PFL204	12200	6300
204-12	3/4	3 35/64	2 13/16	2 41/64	5/8	2 3/4	0,157	2 13/64	5/16	1,2204	0,2953	SA204-12		0,9843	0,2756	SB204-12				
BPFL-SA BPFL-SB 205	25	95	76	71	18	9	4	60	M8	31	7,5	SA205	0,32	27	7,5	SB205	0,28	PFL205	13300	7460
205-13	1 3/16											SA205-13				SB205-13				
205-14	7/8	3 3/4	2 53/64	2 51/64	2 3/32	2 3/64	0,157	2 23/64	5/16	1,2204	0,2953	SA205-14		1,0630	0,2953	SB205-14				
205-15	1 5/16											SA205-15				SB205-15				
205-16	1											SA205-16				SB205-16				
BPFL-SA BPFL-SB 206	30	113	90,5	84	18	11	5,2	71	M10	35,7	9	SA206	0,41	30	8	SB206	0,38	PFL206	18500	10800
206-17	1 1/16											SA206-17				SB206-17				
206-18	1 1/8	4 7/16	3 3/16	3 5/16	2 3/32	7/16	0,205	2 51/64	3/8	1,4055	0,3543	SA206-18		1,1811	0,3150	SB206-18				
206-19	1 3/16											SA206-19				SB206-19				
206-20	1 1/4											SA206-20				SB206-20				
BPFL-SA BPFL-SB 207	35	122	100	94	20	11	5,2	81	M10	38,9	9,5	SA207	0,52	32	8,5	SB207	0,50	PFL207	24500	14600
207-20	1 1/4											SA207-20				SB207-20				
207-21	1 3/16	4 13/16	3 15/16	3 45/64	2 5/32	7/16	0,205	3 3/16	3/8	1,5315	0,3740	SA207-21		1,2598	0,3346	SB207-21				
207-22	1 3/8											SA207-22				SB207-22				
207-23	1 7/16											SA207-23				SB207-23				
BPFL-SA BPFL-SB 208	40	148	119	100	21	13,5	6,8	91	M12	43,7	11	SA208	0,83	34	9	SB208	0,80	PFL208	27700	17000
208-24	1 1/2	5 13/16	4 11/16	3 15/16	1 3/16	1 7/32	0,268	3 37/64	1/2	1,7205	0,4331	SA208-24		1,3386	0,3543	SB208-24				
208-25	1 9/16											SA208-25				SB208-25				

Disponibile in acciaio inox Supporto: AISI 304 - Cuscinetto: AISI 440C o 420C - Available stainless steel Housing: AISI 304 - Bearing: AISI 440C or 420C.

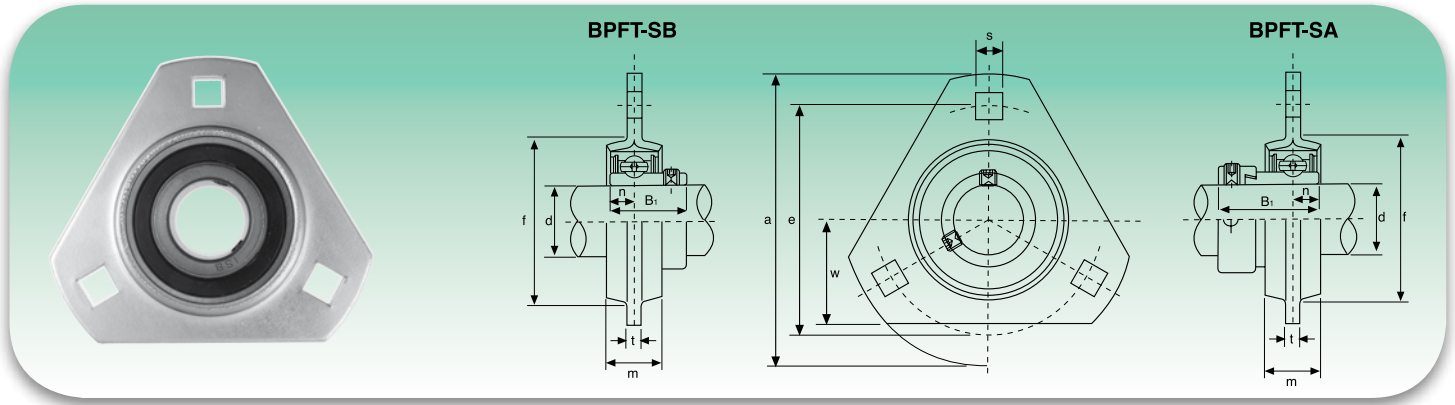

Tipo Type	Dimensioni - Dimensions								Bull. fiss. Bolt Size	BPFT-SA		Cuscinetto Bearing	Peso Weight	BPFT-SB		Cuscinetto Bearing	Peso Weight	Supporto Housing	Coefficienti di carico (N) Load ratings (N)	
	d	a	e	w	m	s	t	f _(min)		B ₁	n			B ₁	n				Dinamico C Dynamic C	Statico C ₀ Static C ₀
	mm/inch									mm/inch				mm/inch						
BPFT-SA BPFT-SB 201 201-8	12 ¾	81 3 ¾	63,5 2 ½	28,5 1 ½	14 ¾	7,1 ⅞	4 1 ⁵⁄₈	49 1 ⁵⁄₈	M6 ¼	28,6 1,1260	6,5 0,2559	SA201 SA201-8	0,26	22 0,8661	6 0,2362	SB201 SB201-8	0,23	PFT203	9200	4480
BPFT-SA BPFT-SB 202 202-9 202-10	15 ⅞ ⅝	81 3 ¾	63,5 2 ½	28,5 1 ½	14 ¾	7,1 ⅞	4 1 ⁵⁄₈	49 1 ⁵⁄₈	M6 ¼	28,6 1,1260	6,5 0,2559	SA202 SA202-9 SA202-10	0,26	22 0,8661	6 0,2362	SB202 SB202-9 SB202-10	0,23	PFT203	9200	4480
BPFT-SA BPFT-SB 203 203-11	17 1 ⅛	81 3 ¾	63,5 2 ½	28,5 1 ½	14 ¾	7,1 ⅞	4 1 ⁵⁄₈	49 1 ⁵⁄₈	M6 ¼	28,6 1,1260	6,5 0,2559	SA203 SA203-11	0,26	22 0,8661	6 0,2362	SB203 SB203-11	0,23	PFT203	9200	4480
BPFT-SA BPFT-SB 204 204-12	20 ¾	90 3 ¾	71,5 2 ¾	33 1 ¾	16 ⅝	9 ¾	4 1 ⁵⁄₈	56 2 ¼	M8 ⅝	31 1,2204	7,5 0,2953	SA204 SA204-12	0,28	25 0,9843	7 0,2756	SB204 SB204-12	0,28	PFT204	12200	6300
BPFT-SA BPFT-SB 205 205-13 205-14 205-15 205-16	25 1 ⅜ ⅞ 1 ⅛ 1	95 3 ¾	76 2 ⅝	35 1 ⅜	18 ⅞	9 ⅞	4 1 ⁵⁄₈	60 2 ⅜	M8 ⅝	31 1,2204	7,5 0,2953	SA205 SA205-13 SA205-14 SA205-15 SA205-16	0,36	27 1,0630	7,5 0,2953	SB205 SB205-13 SB205-14 SB205-15 SB205-16	0,36	PFT205	13300	7460
BPFT-SA BPFT-SB 206 206-17 206-18 206-19 206-20	30 1 ⅛ 1 ⅞ 1 ¾ 1 ¼	113 4 ⅞	90,5 3 ⅞	40 1 ¾	18 ⅞	11 ⅞	5,2 2 ⅞	71 2 ⅞	M10 ¾	35,7 1,4055	9 0,3543	SA206 SA206-17 SA206-18 SA206-19 SA206-20	0,58	30 1,1811	8 0,3150	SB206 SB206-17 SB206-18 SB206-19 SB206-20	0,55	PFT206	18500	10800
BPFT-SA BPFT-SB 207 207-20 207-21 207-22 207-23	35 1 ¼ 1 ⅜ 1 ⅞ 1 ⅞	122 4 ⅞	100 3 ⅞	44,5 1 ¾	20 ⅞	11 ⅞	5,2 2 ⅞	81 3 ⅞	M10 ¾	38,9 1,5315	9,5 0,3740	SA207 SA207-20 SA207-21 SA207-22 SA207-23	0,82	32 1,2598	8,5 0,3346	SB207 SB207-20 SB207-21 SB207-22 SB207-23	0,74	PFT207	24500	14600
BPFT-SA BPFT-SB 208 208-24 208-25	40 1 ½ 1 ⅞	148 5 ⅞	119 4 ⅞	55 2 ⅞	23 ⅞	13,5 0,531	5,8 0,228	85 3,646	M15 ⅞	43,7 1,7201	11 0,4331	SA208 SA208-24 SA208-25	1,05	34 -	9 0,3543	SB208 SB208-24 SB208-25	0,90	PFT208	27700	17000

Disponibile in acciaio inox Supporto: AISI 304 - Cuscinetto: AISI 440C o 420C - Available stainless steel Housing: AISI 304 - Bearing: AISI 440C or 420C.

CUSCINETTI

BEARING



SUPPORTI RITTI IN DUE METÀ

PLUMMER BLOCKS

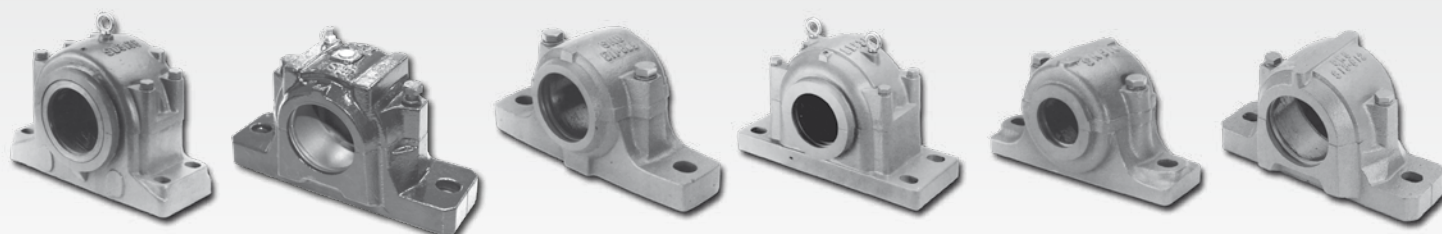

SUPPORTI FLANGIATI

HOUSINGS



SUPPORTI IN PLASTICA

PLASTIC BEARING UNITS

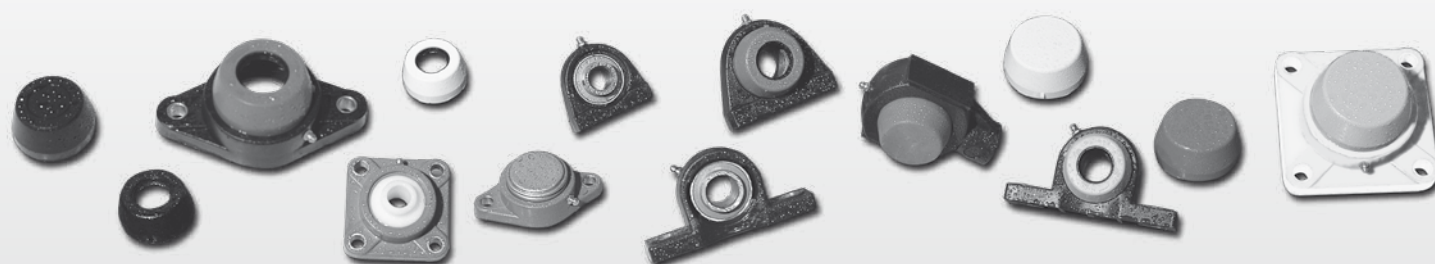

SUPPORTI PER VITI A RICIRCOLO DI SFERE

SUPPORTS OF BALL SCREWS



UC2 Serie normale - Standard duty



Suffisso UNF: Misure in pollici dei grani di bloccaggio
UNF suffix: inch sizes set screws

Tipo Type	Dimensioni - Dimensions									Coefficienti di carico (N) Load ratings (N)		Peso Weight kg
	d	D	B	C	S	S ₁	G	ds	F	Dinamico C Dynamic C	Statico C ₀ Static C ₀	
	mm/inch											
UC201	12	47	31	17	12,7	18,3	4,8	M6x1	3,7	12160	6318	0,20
UC201-8	3/4	1,8504	1,2205	0,6693	0,500	0,720	0,189	1/4-28UNF	0,146			
UC202	15	47	31	17	12,7	18,3	4,8	M6x1	3,7	12160	6318	0,19
UC202-9	9/16	1,8504	1,2205	0,6693	0,500	0,720	0,189	1/4-28UNF	0,146			
UC202-10	5/8											
UC203	17	47	31	17	12,7	18,3	4,8	M6x1	3,7	12160	6318	0,18
UC203-11	1 1/16	1,8504	1,2205	0,6693	0,500	0,720	0,189	1/4-28UNF	0,146			
*UC204	20	47	31	17	12,7	18,3	4,8	M6x1	3,7	12160	6318	0,16
UC204-12	3/4	1,8504	1,2205	0,6693	0,500	0,720	0,189	1/4-28UNF	0,146			
*UC205	25	52	34,1	17	14,3	19,8	5	M6x1	3,9	13300	7457	0,20
UC205-13	1 3/16	2,0472	1,3425	0,6693	0,563	0,780	0,197	1/4-28UNF	0,154			
UC205-14	7/8											
UC205-15	1 1/16											
UC205-16	1											
*UC206	30									62	38,1	19
UC206-17	1 1/16	2,4409	1,5000	0,7480	0,626	0,874	0,197	1/4-28UNF	0,197			
UC206-18	1 1/8											
UC206-19	1 3/16											
UC206-20	1 1/4											
*UC207	35									72	42,9	20
UC207-20	1 1/4	2,8346	1,6890	0,7874	0,689	1,000	0,276	3/16-24UNF	0,224			
UC207-21	1 3/16											
UC207-22	1 3/8											
UC207-23	1 7/16											
*UC208	40									80	49,2	21
UC208-24	1 1/2	3,1496	1,9370	0,8268	0,748	1,189	0,315	3/16-24UNF	0,244			
UC208-25	1 5/16											
*UC209	45									85	49,2	22
UC209-26	1 3/8	3,3465	1,9370	0,8661	0,748	1,189	0,315	3/16-24UNF	0,252			
UC209-27	1 1/16											
UC209-28	1 3/4											
*UC210	50									90	51,6	24
UC210-29	1 13/16	3,5433	2,0315	0,9449	0,748	1,283	0,394	3/8-24UNF	0,256			
UC210-30	1 7/8											
UC210-31	1 15/16											
UC210-32	2											
*UC211	55									100	55,6	25
UC211-32	2	3,9370	2,1890	0,9843	0,874	1,315	0,394	3/8-24UNF	0,276			
UC211-33	2 1/16											
UC211-34	2 1/8											
UC211-35	2 3/16											
*UC212	60									110	65,1	27
UC212-36	2 3/4	4,3307	2,5630	1,0630	1,000	1,563	0,394	3/8-24UNF	0,299			
UC212-37	2 5/16											
UC212-38	2 3/8											
UC212-39	2 1/2											
UC213	65	120	65,1	28	25,4	39,7	10	M10x1	8,5	54340	38095	1,85
UC213-40	2 1/2	4,7244	2,5630	1,1024	1,000	1,563	0,394	3/8-24UNF	0,335			
UC213-41	2 5/16											
UC214	70									125	74,6	29
UC214-42	2 3/8	4,9213	2,9370	1,1417	1,189	1,748	0,472	7/16-20UNF	0,350			
UC214-43	2 1/16											
UC214-44	2 3/4											
UC215	75									130	77,8	30
UC215-45	2 13/16	5,1181	3,0630	1,1811	1,311	1,752	0,472	7/16-20UNF	0,362			
UC215-46	2 7/8											
UC215-47	2 15/16											
UC215-48	3											
UC216	80									140	82,6	32
UC216-49	3 1/16	5,5118	3,2520	1,2598	1,311	1,9409	0,472	7/16-20UNF	0,374			
UC216-50	3 3/8											
UC216-51	3 3/16											
UC217	85	150	85,7	34	34,1	51,6	12	M12x1,5	10,2	79800	58805	3,46
UC217-52	3 1/4	5,9055	3,3740	1,3386	1,343	2,031	0,472	7/16-20UNF	0,402			
UC217-53	3 3/16											
UC217-54	3 1/2											
UC217-55	3 5/16											
UC218	90	160	96	36	39,7	56,3	12	M12x1,5	11,2	91295	67925	4,36
UC218-56	3 1/2	6,2992	3,7795	1,4173	1,5630	2,217	0,472	7/16-20UNF	0,441			

Disponibile in acciaio inox AISI 440C o 420C - Available stainless steel AISI 440C or 420C

*Fornito con schermo antipolvere a stella, grano con sfera e anello interno brunito - Equipped with anti-rust shield star shape, screw with ball and burnished inner ring

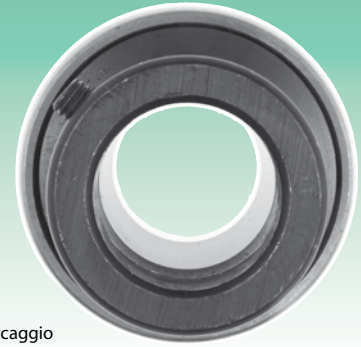
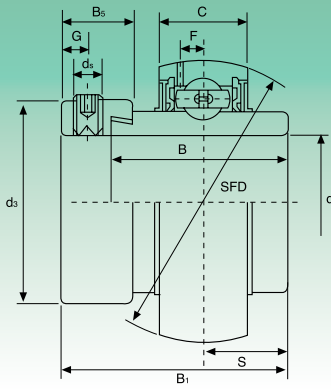
HC2 Serie normale - Standard duty



Suffisso UNF: Misure in pollici dei grani di bloccaggio
UNF suffix: inch sizes set screws

Tipo Type	Dimensioni - Dimensions											Coefficienti di carico (N) Load ratings (N)		Peso Weight kg
	d	D	B ₁	B	C	S	d _s	G	B _s	d _a	F	Dinamico C Dynamic C	Statico C ₀ Static C ₀	
	mm/inch													
HC204	20	47	43,7	34,2	17	17,1	M6x1	4,8	13,5	33,3	3,7	12160	6318	0,23
HC204-12	¾	1,8504	1,720	1,3465	0,6693	0,673	¼-28UNF	0,189	0,531	1,311	0,146			0,23
HC205	25	52	44,4	34,9	17	17,5	M6x1	4,8	13,5	38,1	3,9	13300	7457	0,27
HC205-13	13/16													0,32
HC205-14	7/8	2,0472	1,748	1,3740	0,6693	0,689	¼-28UNF	0,189	0,531	1,500	0,154			0,31
HC205-15	15/16													0,29
HC205-16	1													0,27
HC206	30	62	48,4	36,5	19	18,3	M8x1	6	15,9	44,5	5,0	18525	10735	0,45
HC206-17	1 1/16													0,50
HC206-18	1 1/8	2,4409	1,906	1,4370	0,7480	0,720	5/16-24UNF	0,236	0,626	1,752	0,197			0,47
HC206-19	1 3/16													0,45
HC206-20	1 1/4													0,42
HC207	35	72	51,1	37,6	20	18,8	M8x1	6,8	17,5	55,6	5,7	24415	14630	0,60
HC207-20	1 1/4													0,67
HC207-21	1 3/16	2,8346	2,012	1,4803	0,7874	0,740	5/16-24UNF	0,268	0,689	2,189	0,224			0,63
HC207-22	1 3/8													0,60
HC207-23	1 7/16													0,57
HC208	40	80	56,3	42,8	21	21,4	M8x1	6,8	18,3	60,3	6,2	27645	16910	0,79
HC208-24	1 1/2	3,1496	2,217	1,6850	0,8268	0,843	5/16-24UNF	0,268	0,720	2,374	0,244			0,84
HC208-25	1 5/16													0,80
HC209	45	85	56,3	42,8	22	21,4	M8x1	6,8	18,3	63,5	6,4	32395	20235	0,85
HC209-26	1 5/8													0,96
HC209-27	1 11/16	3,3465	2,217	1,6850	0,8661	0,843	5/16-24UNF	0,268	0,720	2,5000	0,252			0,91
HC209-28	1 3/4													0,87
HC210	50	90	62,7	49,2	24	24,6	M8x1	6,8	18,3	69,9	6,5	33345	22135	0,99
HC210-29	1 13/16													1,14
HC210-30	1 7/8	3,5433	2,469	1,9370	0,9449	0,969	5/16-24UNF	0,268	0,720	2,752	0,256			1,08
HC210-31	1 15/16													1,02
HC210-32	2													0,96
HC211	55	100	71,4	55,5	25	27,8	M10x1	8	20,7	76,2	7,0	41230	27930	1,32
HC211-32	2													1,52
HC211-33	2 1/16	3,9370	2,811	2,1850	0,9843	1,094	3/8-24UNF	0,315	0,815	3,000	0,276			1,44
HC211-34	2 1/8													1,37
HC211-35	2 3/16													1,29
HC212	60	110	77,8	61,9	27	31	M10x1	8	22,3	84,2	7,6	49780	34390	1,88
HC212-36	2 1/4													2,04
HC212-37	2 5/16	4,3307	3,063	2,4370	1,0630	1,220	3/8-24UNF	0,315	0,878	3,315	0,299			1,95
HC212-38	2 3/8													1,90
HC212-39	2 7/16													1,77
HC213	65	120	85,7	68,6	28	34,1	M10x1	8,5	23,5	86	8,5	54340	38095	2,41
HC213-40	2 1/2	4,7244	3,374	2,7008	1,1024	1,343	3/8-24UNF	0,335	0,925	3,386	0,335			2,51
HC213-41	2 9/16													2,40
HC214	70	125	85,7	68,6	29	34,1	M10x1	8,5	23,5	90	8,9	59090	41895	2,55
HC214-42	2 3/8													2,79
HC214-43	2 11/16	4,9213	3,374	2,7008	1,1417	1,343	3/8-24UNF	0,335	0,925	3,543	0,350			2,68
HC214-44	2 3/4													2,56
HC215	75	130	92,1	75	30	37,3	M10x1	8,5	23,5	102	9,2	64030	45885	2,84
HC215-45	2 13/16													3,14
HC215-46	2 7/8	5,1181	3,626	2,9528	1,1811	1,469	3/8-24UNF	0,335	0,925	4,016	0,362			3,01
HC215-47	2 15/16													2,88
HC215-48	3													2,74

Disponibile in acciaio inox AISI 440C o 420C - Available stainless steel AISI 440C or 420C

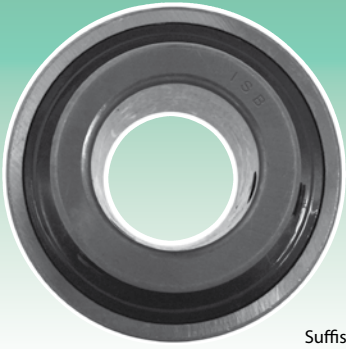
UCX Serie media - Medium duty

Suffisso UNF: Misure in pollici dei grani di bloccaggio
 UNF suffix: inch sizes set screws

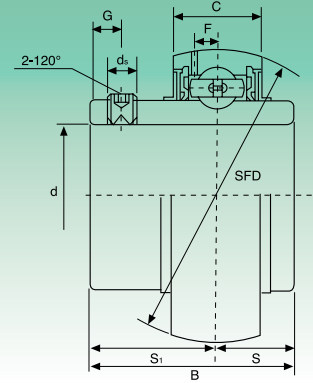

Tipo Type	Dimensioni - Dimensions									Coefficienti di carico (N) Load ratings (N)		Peso Weight kg
	d	D	B	C	S	S ₁	G	ds	F	Dinamico C Dynamic C	Statico C ₀ Static C ₀	
	mm/inch											
UCX05	25	62	38,1	19	15,9	22,2	5	M6x1	5,0			
UCX05-13	13/16											
UCX05-14	7/8	2,4409	1,5000	0,7480	0,626	0,874	0,197	1/4-28UNF	0,197	18525	10735	0,39
UCX05-15	15/16											
UCX05-16	1											
UCX06	30	72	42,9	20	17,5	25,4	7	M8x1	5,7			
UCX06-17	1 1/16											
UCX06-18	1 1/8	2,8346	1,6890	0,7874	0,689	1,000	0,276	5/16-24UNF	0,224	24415	14630	0,68
UCX06-19	1 3/8											
UCX06-20	1 1/4											
UCX07	35	80	49,2	21	19	30,2	8	M8x1	6,2			
UCX07-21	1 3/8											
UCX07-22	1 3/8	3,1496	1,9370	0,8268	0,748	1,189	0,315	5/16-24UNF	0,244	27645	16910	0,82
UCX07-23	1 7/8											
UCX08	40	85	49,2	22	19	30,2	8	M8x1	6,4			
UCX08-24	1 1/2											
UCX08-25	1 3/4	3,3465	1,9370	0,8661	0,748	1,189	0,315	5/16-24UNF	0,252	32395	20235	0,93
UCX09	45	90	51,6	24	19	32,6	10	M10x1	6,5			
UCX09-26	1 3/8											
UCX09-27	1 11/16	3,5433	2,0315	0,9449	0,748	1,283	0,394	3/8-24UNF	0,256	33345	22135	1,00
UCX09-28	1 3/4											
UCX10	50	100	55,6	25	22,2	33,4	10	M10x1	7,0			
UCX10-30	1 7/8											
UCX10-31	1 5/8	3,9370	2,1890	0,9843	0,874	1,315	0,394	3/8-24UNF	0,276	41230	27930	1,35
UCX10-32	2											
UCX11	55	110	65,1	27	25,4	39,7	10	M10x1	7,6			
UCX11-33	2 1/8											
UCX11-34	2 1/8											
UCX11-35	2 3/8	4,3307	2,5630	1,0630	1,000	1,563	0,394	3/8-24UNF	0,299	49780	34390	1,90
UCX11-36	2 1/4											
UCX12	60	120	65,1	28	25,4	39,7	10	M10x1	8,5			
UCX12-38	2 3/8											
UCX12-39	2 1/2	4,7244	2,5630	1,1024	1,000	1,563	0,394	3/8-24UNF	0,335	54340	38095	2,27
UCX13	65	125	74,6	29	30,2	44,4	12	M12x1,5	8,9			
UCX13-40	2 1/2											
UCX13-41	2 5/8	4,9213	2,9370	1,1417	1,189	1,748	0,472	7/16-20UNF	0,350	59090	41895	2,45
UCX14	70	130	77,8	30	33,3	44,5	12	M12x1,5	9,2			
UCX14-42	2 3/8											
UCX14-43	2 11/16	5,1181	3,0630	1,1811	1,311	1,752	0,472	7/16-20UNF	0,362	64030	45885	2,47
UCX14-44	2 3/4											
UCX15	75	140	82,6	32	33,3	49,3	12	M12x1,5	9,5			
UCX15-45	2 13/16											
UCX15-46	2 7/8	5,5118	3,2520	1,2598	1,311	1,9409	0,472	7/16-20UNF	0,374	69065	50350	3,11
UCX15-47	2 15/16											
UCX15-48	3											
UCX16	80	150	85,7	34	34,1	51,6	12	M12x1,5	10,2			
UCX16-49	3 1/8											
UCX16-50	3 1/8	5,9055	3,3740	1,3386	1,343	2,031	0,472	7/16-20UNF	0,402	79800	58805	3,79
UCX16-51	3 3/8											
UCX17	85	160	96	36	39,7	56,3	12	M12x1,5	11,2			
UCX17-53	3 3/8											
UCX17-55	3 7/8	6,2992	3,7795	1,4173	1,5630	2,217	0,472	1/2-20UNF	0,441	91295	67925	4,82
UCX18	90	170	104	39	42,9	61,1	14	M14x1,5	10,5			
UCX18-56	3 7/8											
UCX18-57	3 1/2	6,6929	4,0945	1,5354	1,689	2,406	0,511	9/16-18UNF	0,413	103550	77805	5,51
UCX20	100	190	117,5	44	49,2	68,3	16	M16x1,5	11,3			
UCX20-58	3 13/16											
UCX20-59	3 7/8											
UCX20-60	3 15/16											
UCX20-61	4	7,4803	4,6260	1,7323	1,937	2,689	0,630	5/8-18UNF	0,445	126350	99750	8,95
UCX20-62	4											
UCX20-64	4											

UC3 Serie pesante - Heavy duty

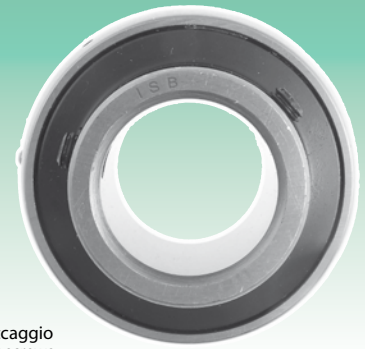
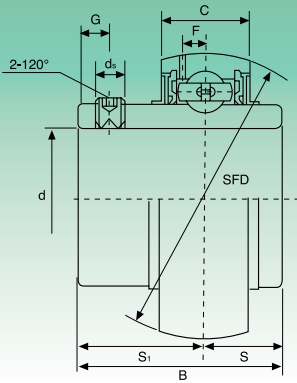

Suffisso UNF: Misure in pollici dei grani di bloccaggio
UNF suffix: inch sizes set screws

Tipo Type	Dimensioni - Dimensions									Coefficienti di carico (N) Load ratings (N)		Peso Weight kg
	d	D	B	C	S	S ₁	G	ds	F	Dinamico C Dynamic C	Statico C ₀ Static C ₀	
	mm/inch											
UC305	25	62	38	20	15	23	6	M6x1	5,4			0,35
UC305-13	1 ³ / ₁₆											0,40
UC305-14	7 ⁷ / ₁₆	2,4409	1,4961	0,7874	0,591	0,906	0,236	¼-28UNF	0,213	20140	10355	0,38
UC305-15	1 ⁵ / ₁₆											0,36
UC305-16	1											0,35
UC306	30	72	43	23	17	26	6	M6x1	5,7			0,56
UC306-17	1 ¹ / ₁₆											0,61
UC306-18	1 ¹ / ₈	2,8346	1,6929	0,9055	0,669	1,024	0,236	¼-28UNF	0,225	25365	14250	0,58
UC306-19	1 ³ / ₁₆											0,56
UC307	35	80	48	25	19	29	8	M8x1	6,2			0,71
UC307-20	1 ¹ / ₄											0,77
UC307-21	1 ⁵ / ₁₆	3,1496	1,8898	0,9843	0,748	1,142	0,315	5 ¹⁶ / ₁₆ -24UNF	0,224	31730	18335	0,74
UC307-22	1 ³ / ₈											0,71
UC307-23	1 ⁷ / ₁₆											0,68
UC308	40	90	52	27	19	33	10	M10x1	7,0			0,96
UC308-24	1 ¹ / ₂											1,01
UC308-25	1 ⁹ / ₁₆	3,5433	2,0472	1,0630	0,748	1,299	0,394	¾-24UNF	0,276	38665	22800	0,97
UC309	45	100	57	30	22	35	10	M10x1	7,8			1,28
UC309-26	1 ³ / ₈											1,39
UC309-27	1 ¹¹ / ₁₆	3,9370	2,2441	1,1811	0,866	1,378	0,394	¾-24UNF	0,307	46455	28025	1,35
UC309-28	1 ³ / ₄											1,30
UC310	50	110	61	32	22	39	12	M12x1,5	8,5			1,65
UC310-29	1 ¹³ / ₁₆											1,97
UC310-30	1 ⁷ / ₈	4,3307	2,4016	1,2598	0,866	1,535	0,472	7 ¹⁶ / ₁₆ -20UNF	0,335	58900	36385	1,74
UC310-31	1 ⁵ / ₈											1,68
UC311	55	120	66	34	25	41	12	M12x1,5	9,2			2,07
UC311-32	2											2,25
UC311-33	2 ¹ / ₁₆	4,7244	2,5984	1,3386	0,984	1,614	0,472	7 ¹⁶ / ₁₆ -20UNF	0,362	68020	42750	2,18
UC311-34	2 ¹ / ₈											2,12
UC311-35	2 ³ / ₁₆											2,04
UC312	60	130	71	36	26	45	12	M12x1,5	9,8			2,60
UC312-36	2 ¹ / ₄											2,75
UC312-37	2 ³ / ₁₆	5,1181	2,7953	1,4173	1,0236	1,772	0,472	7 ¹⁶ / ₁₆ -20UNF	0,386	77805	49590	2,67
UC312-38	2 ³ / ₈											2,58
UC312-39	2 ⁷ / ₁₆											2,50
UC313	65	140	75	38	30	45	12	M12x1,5	10,5			3,25
UC313-40	2 ¹ / ₂											3,34
UC313-41	2 ⁹ / ₁₆	5,5118	2,9528	1,4961	1,181	1,772	0,472	7 ¹⁶ / ₁₆ -20UNF	0,413	88065	56905	3,24
UC314	70	150	78	40	33	45	12	M12x1,5	11,1			3,89
UC314-42	2 ⁵ / ₈											4,11
UC314-43	2 ¹ / ₁₆	5,9055	3,0708	1,5748	1,299	1,772	0,472	7 ¹⁶ / ₁₆ -20UNF	0,437	98800	64790	4,00
UC314-44	2 ³ / ₄											3,90
UC315	75	160	82	42	32	50	14	M14x1,5	11,8			4,72
UC315-45	2 ¹³ / ₁₆											4,99
UC315-46	2 ⁷ / ₈	6,2992	3,2283	1,6535	1,260	1,969	0,551	9 ¹⁶ / ₁₆ -18UNF	0,465	107350	73340	4,85
UC315-47	2 ¹⁵ / ₁₆											4,76
UC315-48	3											4,63
UC316	80	170	86	44	34	52	14	M14x1,5	12,5			5,55
UC316-49	3 ¹ / ₁₆											5,72
UC316-50	3 ³ / ₁₆	6,6929	3,3858	1,7323	1,339	2,047	0,551	9 ¹⁶ / ₁₆ -18UNF	0,492	116850	82365	5,58
UC316-51	3 ⁵ / ₁₆											5,49
UC317	85	180	96	46	40	56	16	M16x1,5	13,1			6,67
UC317-52	3 ¹ / ₄											6,89
UC317-53	3 ³ / ₁₆	7,0866	3,7795	1,8110	1,575	2,205	0,630	9 ¹⁶ / ₁₆ -18UNF	0,516	126350	91960	6,76
UC317-55	3 ⁷ / ₁₆											6,44
UC318	90	190	96	48	40	56	16	M16x1,5	13,8			7,56
UC318-55	3 ⁵ / ₁₆											7,85
UC318-56	3 ¹ / ₂	7,4803	3,7795	1,8898	1,575	2,205	0,630	9 ¹⁶ / ₁₆ -18UNF	0,543	135850	101650	7,67
UC319	95	200	103	50	41	62	16	M16x1,5	14,7			8,70
UC319-58	3 ⁵ / ₈											9,03
UC319-59	3 ¹ / ₁₆	7,8740	4,0551	1,9685	1,614	2,441	0,630	9 ¹⁶ / ₁₆ -18UNF	0,579	145350	113050	8,85
UC319-60	3 ³ / ₄											8,66
UC320	100	215	108	55	42	66	18	M18x1,5	13,5			10,80
UC320-61	3 ¹³ / ₁₆											11,20
UC320-62	3 ⁷ / ₈	8,4646	4,2520	2,1654	1,654	2,598	0,709	9 ¹⁶ / ₁₆ -18UNF	0,531	164350	133950	10,98
UC320-63	3 ¹⁵ / ₁₆											10,80
UC320-64	4											10,60
UC321	105	225	112	56	44	68	18	M18x1,5	19,1	174800	145350	12,20
UC322	110	240	117	60	46	71	18	M18x1,5	20,6	194750	171000	14,30
UC324	120	260	126	64	51	75	18	M18x1,5	20,6	196650	175750	18,50
UC326	130	280	135	68	54	81	20	M20x1,5	22,2	217550	203300	23,00
UC328	140	300	145	73	59	86	22	M20x1,5	23,8	240350	233700	28,50

Disponibile in acciaio inox AISI 440C o 420C - Available stainless steel AISI 440C or 420C

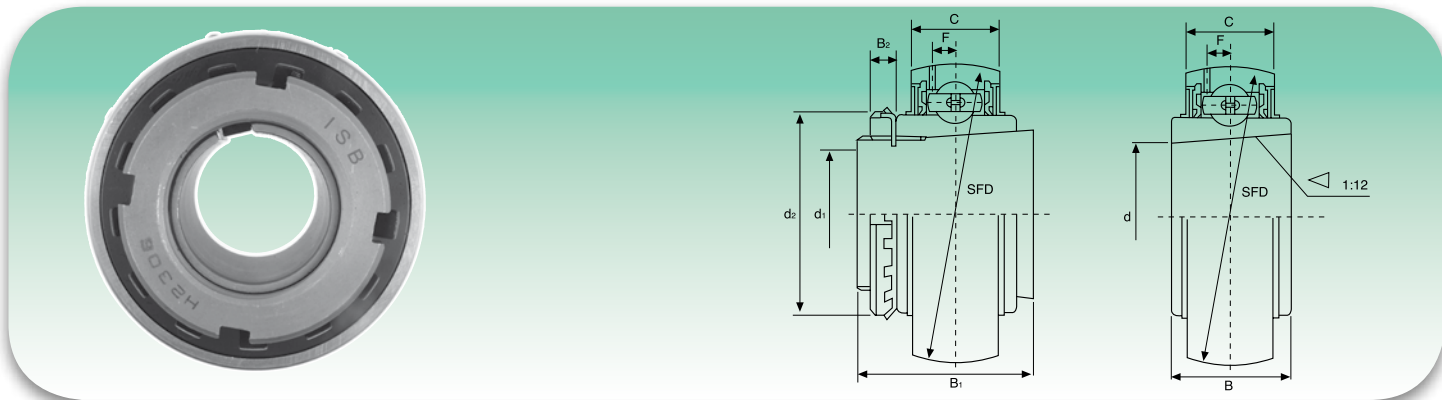
UK2 Serie normale - Standard duty

Tipo Type	Dimensioni - Dimensions									Coefficienti di carico (N) Load ratings (N)		Peso Weight kg
	d	D	B	C	d ₁	B ₁	B ₂	d ₂	F	Dinamico C Dynamic C	Statico C ₀ Static C ₀	
	mm/inch											
UK205+H2305	25	52	23	17	20	35	8	38	3,9	13300	7457	0,25
UK205+HE2305	0,9843	2,0472	0,9055	0,6693	¾	1,378	0,315	1,496	0,154			
UK206+H2306	30	62	26	19	25	38	8	45	5,0	18525	10735	0,36
UK206+HS2306	1,1811	2,4409	1,0236	0,7480	1	1,496	0,315	1,772	0,197			
UK207+H2307	35	72	29	20	30	43	9	52	5,7	24415	14630	0,57
UK207+HS2307	1,3780	2,8346	1,1417	0,7874	1½	1,693	0,354	2,047	0,224			
UK208+H2308	40	80	31	21	35	46	10	58	6,2	27645	16910	0,74
UK208+HE2308	1,5748	3,1496	1,2205	0,8268	1¼	1,811	0,394	2,283	0,244			
UK209+H2309	45	85	31	22	40	50	11	65	6,4	32395	20235	0,83
UK209+HA2309					1⅞							
UK209+HE2309	1,7717	3,3465	1,2205	0,8661	1½	1,969	0,433	2,559	0,252			
UK210+H2310	50	90	32	24	45	55	12	70	6,5	33345	22135	0,97
UK210+HS2310					1½							
UK210+HA2310	1,9685	3,5433	1,2598	0,9449	1⅞	2,165	0,472	2,756	0,256			
UK211+H2311	55	100	35	25	50	59	12	75	7,0	41230	27930	1,26
UK211+HS2311					1¾							
UK211+HA2311	2,1654	3,9370	1,3780	0,9843	1⅞	2,323	0,472	2,953	0,276			
UK212+H2312	60	110	38	27	55	62	13	80	7,6	49780	34390	1,59
UK212+HS2312	2,3622	4,3307	1,4961	1,0630	2½	2,441	0,512	3,150	0,299			
UK213+H2313	65	120	40	28	60	65	14	85	8,5	54340	38095	1,76
UK213+HA2313					2⅞							
UK213+HE2313	2,5591	4,7244	1,5748	1,1024	2¼	2,559	0,551	3,346	0,335			
UK215+H2315	75	130	44	30	65	73	15	98	9,2	64030	45885	2,32
UK215+HA2315					2⅞							
UK215+HE2315	2,9528	5,1181	1,7323	1,1811	2½	2,874	0,591	3,858	0,362			
UK216+H2316	80	140	45	32	70	78	17	105	9,5	69065	50350	3,06
UK216+HA2316					2⅞							
UK216+HE2316	3,1496	5,5118	1,7717	1,2598	2¾	3,071	0,669	4,134	0,374			
UK217+H2317	85	150	46	34	75	82	18	110	10,2	79800	58805	3,88
UK217+HA2317					2⅞							
UK217+HE2317	3,3465	5,9055	1,8110	1,3386	3	3,228	0,709	4,331	0,402			
UK218+H2318	90	160	47	36	80	86	18	120	11,2	91295	67925	4,74
UK218+HA2318	3,5433	6,2992	1,8504	1,4173	3⅞	3,386	0,709	4,724	0,441			

Disponibile in acciaio inox AISI 440C o 420C - Available stainless steel AISI 440C or 420C
 Bussole HA; HE; HS con filettatura in pollici - Inch dimension adapter sleeves HA; HE; HS

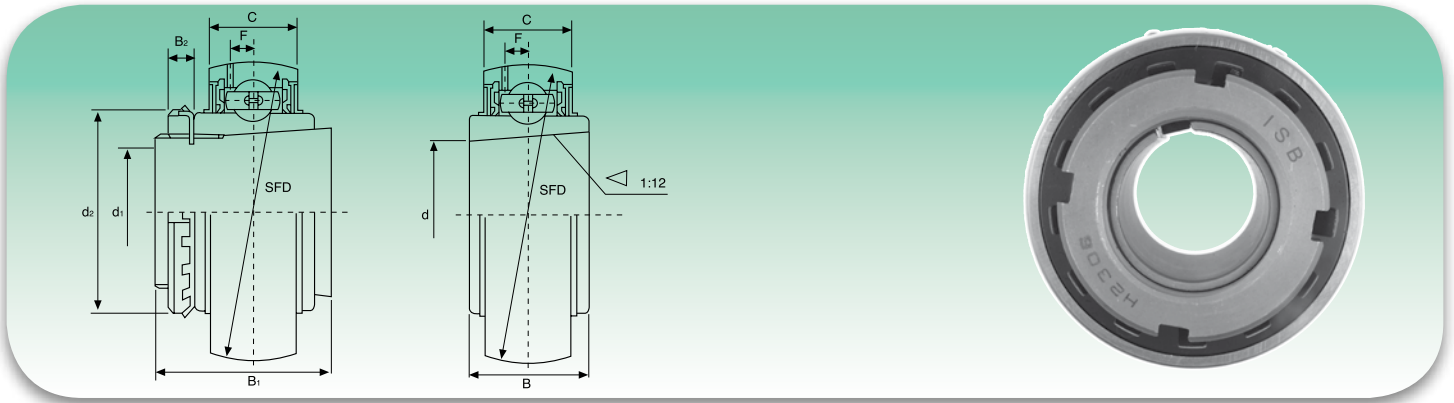

Tipo Type	Dimensioni - Dimensions									Coefficienti di carico (N) Load ratings (N)		Peso Weight kg
	d	D	B	C	d ₁	B ₁	B ₂	d ₂	F	Dinamico C Dynamic C	Statico C ₀ Static C ₀	
	mm/inch											
UKX05+H2305	25	62	26	19	20	35	8	38	5	18525	10735	0,37
UKX05+HE2305	0,9845	2,4409	1,0236	0,7480	3/4	1,378	0,315	1,496	0,197			
UKX06+H2306	30	72	29	20	25	38	8	45	5,7	24415	14630	0,59
UKX06+HS2306	1,1811	2,8346	1,1417	0,7874	7/8	1,496	0,315	1,771	0,244			
UKX06+HE2306					1							
UKX07+H2307	35	80	31	21	30	43	9	52	6,2	27645	18910	0,75
UKX07+HS2307	1,3780	3,1496	1,2205	0,8268	1 1/8	1,693	0,354	2,047	0,244			
UKX08+H2308	40	85	31	22	35	46	10	58	6,4	32395	20235	0,86
UKX08+HE2308	1,5748	3,3465	1,2205	0,8661	1 1/4	1,811	0,394	2,284	0,252			
UKX08+HS2308					1 3/8							
UKX09+H2309	45	90	32	24	40	50	11	65	6,5	33345	22135	0,96
UKX09+HA2309	1,7717	3,5433	1,2598	0,9449	1 7/16	1,969	0,433	2,559	0,256			
UKX09+HE2309					1 1/2							
UKX09+HS2309					1 5/8							
UKX10+H2310	50	100	35	25	45	55	12	70	7,0	41230	27930	1,34
UKX10+HS2310	1,9685	3,9370	1,3780	0,6843	1 1/2	2,165	0,472	2,756	0,726			
UKX10+HA2310					1 11/16							
UKX10+HE2310					1 3/4							
UKX11+H2311	55	100	38	27	50	59	12	75	7,6	49780	34390	1,67
UKX11+HS2311	2,1654	4,3307	1,496	1,0630	1 7/8	2,323	0,472	2,953	0,299			
UKX11+HA2311					1 5/8							
UKX11+HE2311					2							
UKX12+H2312	60	120	40	28	55	62	13	80	8,5	54340	38095	1,84
UKX12+HS2312	2,3622	4,7244	1,5748	1,1024	2 1/8	2,441	0,512	3,150	0,335			
UKX13+H2313	65	125	40	29	60	65	14	85	8,9	59090	41895	2,15
UKX13+HA2313	2,5591	4,9213	1,5748	1,1417	2 3/16	2,559	0,551	3,346	0,350			
UKX13+HE2313					2 1/4							
UKX13+HS2313					2 3/8							
UKX15+H2315	75	140	45	32	65	73	15	98	9,5	69065	50350	3,05
UKX15+HA2315	2,9528	5,5118	1,7717	1,2598	2 7/16	2,874	0,591	3,858	0,374			
UKX15+HS2315					2 1/2							
UKX16+H2316	80	150	46	34	70	78	17	105	10,2	79800	58805	3,95
UKX16+HA2316	3,1496	5,9055	1,811	1,3386	2 11/16	3,071	0,669	4,134	0,402			
UKX16+HS2316					2 3/4							
UKX17+H2317	85	160	47	36	75	82	18	110	11,2	91295	67925	4,83
UKX17+HA2317	3,3465	6,2992	1,8504	1,4173	2 15/16	3,228	0,709	4,331	0,441			
UKX17+HE2317					3							
UKX18+H2318	90	170	52	39	80	86	18	120	12,5	103550	77805	5,45
UKX18+HA2318	3,5433	6,6929	1,9685	1,5354	3 1/16	3,386	0,709	4,724	0,492			

Bussolle HA; HE; HS con filettatura in pollici - Inch dimension adapter sleeves HA; HE; HS

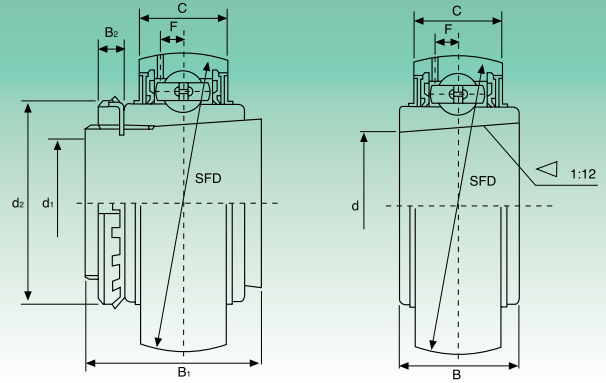
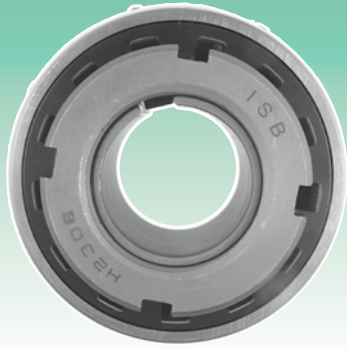
UK3 Serie pesante - Heavy duty

Tipo Type	Dimensioni - Dimensions									Coefficienti di carico (N) Load ratings (N)		Peso Weight kg
	d	D	B	C	d ₁	B ₁	B ₂	d ₂	F	Dinamico C Dynamic C	Statico C ₀ Static C ₀	
	mm/inch											
UK305+H2305	25	62	26	20	20	35	8	38	5,0	20140	10355	0,48
UC305+HE2305	0,9843	2,4409	1,0236	0,7874	¾	1,378	0,315	1,496	0,197			
UK306+H2306	30	72	29	23	25	38	8	45	5,9	25365	14250	0,59
UK306+HS2306	1,1811	2,8346	1,1417	0,9055	7/8	1,496	0,315	1,772	0,232			
UK307+H2307	35	80	33	25	30	43	9	52	6,8	31730	18335	0,76
UK307+HS2307	1,3780	3,1496	1,2992	0,9843	1 1/8	1,693	0,354	2,047	0,268			
UK308+H2308	40	90	34	27	35	46	10	58	7,4	38665	22800	1,07
UK308+HE2308	1,5748	3,5433	1,3386	1,0630	1 1/4	1,811	0,394	2,283	0,291			
UK309+H2309	45	100	37	29	40	50	11	65	7,4	46455	28025	1,31
UK309+HA2309	1,7717	3,9370	1,4567	1,1417	1 7/8	1,969	0,433	2,559	0,291			
UK310+H2310	50	110	41	32	45	55	12	70	8,1	58900	36385	1,70
UK310+HS2310	1,9685	4,3307	1,6142	1,2598	1 1/2	2,165	0,472	2,756	0,319			
UK311+H2311	55	120	44	34	50	59	12	75	8,5	68020	42750	2,06
UK311+HA2311	2,1654	4,7244	1,7323	1,3386	1 7/8	2,323	0,472	2,953	0,335			
UK312+H2312	60	130	47	36	55	62	13	80	9	77805	49590	2,58
UK312+HS2312	2,3622	5,1181	1,8504	1,4173	2 1/8	2,441	0,512	3,150	0,354			
UK313+H2313	65	140	49	39	60	65	14	85	10,1	88065	56905	3,07
UK313+HA2313	2,5591	5,5118	1,9291	1,5354	2 3/8	2,559	0,551	3,346	0,398			
UK315+H2315	75	160	55	43	65	73	15	98	11	107350	73340	4,82
UK315+HA2315	2,9528	6,2992	2,1654	1,6929	2 5/8	2,874	0,591	3,858	0,433			
UK316+H2316	80	170	58	45	70	78	17	105	11,4	116850	82365	5,63
UK316+HE2316	3,1496	6,6929	2,2835	1,7717	2 3/4	3,071	0,669	4,134	0,449			
UK317+H2317	85	180	60	47	75	82	18	110	12,0	126350	91960	6,47
UK317+HA2317	3,3465	7,0866	2,3622	1,8504	2 7/8	3,228	0,709	4,331	0,472			
UK318+H2318	90	190	64	49	80	86	18	120	12,3	135850	101650	7,52
UK318+HA2318	3,5433	7,4803	2,5197	1,9291	3 1/8	3,386	0,709	4,724	0,484			

Bussole HA; HE; HS con filettatura in pollici - Inch dimension adapter sleeves HA; HE; HS

SER2 Serie normale - Standard duty

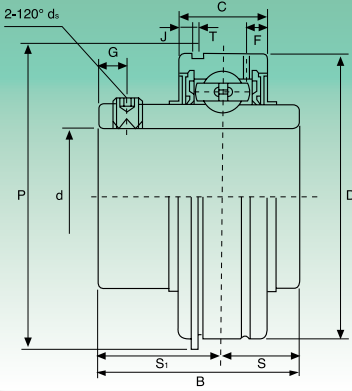

Suffisso UNF: Misure in pollici dei grani di bloccaggio
UNF suffix: inch sizes set screws

Tipo Type	Dimensioni - Dimensions												Coefficienti di carico (N) Load ratings (N)		Peso Weight kg
	d	D	B	C	S	S ₁	T	F	J	P	G	d _s	Dinamico C Dynamic C	Statico C ₀ Static C ₀	
	mm/inch														
SER204	20	47	31	15,9	10,3	20,7	1,12	3,8	2,46	52,7	4,8	M6x1	9880	6200	0,21
SER204-12	¾	1,8504	1,2205	0,6260	0,406	0,815	0,044	0,150	0,097	2,075	0,189	¼-28UNF			
SER205	25	52	34,9	19	13,1	21,8	1,12	5,2	2,46	57,9	5	M6x1	10780	6980	0,27
SER205-13	1⅜														
SER205-14	7/8	2,0472	1,3740	0,7480	0,516	0,858	0,044	0,205	0,097	2,280	0,197	¼-28UNF			
SER205-15	1⅝														
SER205-16	1														
SER206	30	62	38,1	22,2	15,9	22,2	1,7	5,6	3,28	67,7	5	M6x1	14970	10040	0,39
SER206-17	1⅞														
SER206-18	1½	2,4409	1,5000	0,8740	0,626	0,874	0,067	0,220	0,129	2,665	0,197	¼-28UNF			
SER206-19	1⅜														
SER206-20	1¼														
SER207	35	72	42,9	23,8	17,5	25,4	1,7	5,6	3,28	78,6	6,7	M8x1	19750	13670	0,63
SER207-20	1¼														
SER207-21	1⅝	2,8346	1,6890	0,9370	0,689	1,000	0,067	0,220	0,129	3,094	0,264	⅝-24UNF			
SER207-22	1⅜														
SER207-23	1⅞														
SER208	40	80	49,2	27,8	19	30,2	1,7	6,4	3,28	86,6	8	M8x1	22710	14940	0,81
SER208-24	1½	3,1496	1,9370	1,0945	0,748	1,189	0,067	0,252	0,129	3,409	0,315	⅝-24UNF			
SER208-25	1⅞														
SER209	45	85	49,2	27,8	19	30,2	1,7	6,4	3,28	91,6	8	M8x1	24360	17710	0,90
SER209-26	1⅝														
SER209-27	1⅞	3,3465	1,9370	1,0945	0,748	1,189	0,067	0,252	0,129	3,606	0,315	⅝-24UNF			
SER209-28	1¾														
SER210	50	90	51,6	28,6	19	32,6	2,46	7,5	3,28	96,5	10	M10x1	26980	19840	0,98
SER210-29	1⅞														
SER210-30	1⅞	3,5433	2,0315	1,1260	0,748	1,283	0,097	0,295	0,129	3,799	0,394	⅝-24UNF			
SER210-31	1⅝														
SER210-32	2														
SER211	55	100	55,6	30,2	22,2	33,4	2,46	7,5	3,28	106,5	10	M10x1	33370	25110	1,40
SER211-32	2														
SER211-33	2⅞	3,9370	2,1890	1,1890	0,874	1,315	0,097	0,295	0,129	4,193	0,394	⅝-24UNF			
SER211-34	2½														
SER211-35	2⅜														
SER212	60	110	65,1	31,8	25,4	39,7	2,46	7,5	3,28	116,6	10	M10x1	36740	27970	1,89
SER212-36	2¼														
SER212-37	2⅝	4,3307	2,5630	1,2520	1,000	1,563	0,097	0,295	0,129	4,591	0,394	⅝-24UNF			
SER212-38	2⅜														
SER212-39	2⅞														

SA2 Serie leggera - Light duty

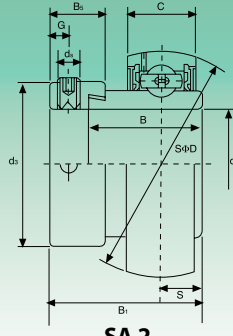

Suffisso UNF: Misure in pollici dei grani di bloccaggio
UNF suffix: inch sizes set screws

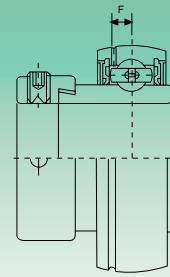

SA 2
anello esterno sferico
outer spherical ring

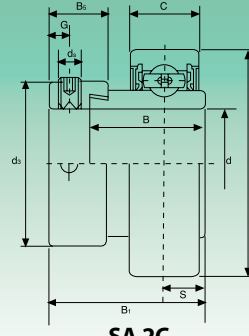

SA 2S
anello esterno sferico,
con gola di lubrificazione
outer spherical ring,
with relubrication groove



SA 2C
anello esterno cilindrico
outer cylindrical ring

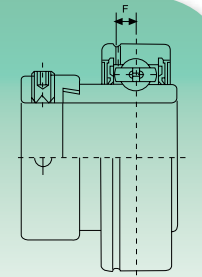

SA 2CS
anello esterno cilindrico,
con gola di lubrificazione
outer cylindrical ring,
with relubrication groove

Tipo Type	Dimensioni - Dimensions											Coefficienti di carico (N) Load ratings (N)		Peso Weight kg
	d	D	B ₁	B	C	S	ds	G	B _s	ds	F	Dinamico C Dynamic C	Statico C ₀ Static C ₀	
	mm/inch													
SA201	12	40	28,6	19,1	12	6,5	M6x1	4,8	13,5	28,6	3,7	9200	4480	0,12
SA201-8	3/4	1,5748	1,126	0,7520	0,4724	0,256	1/4-28UNF	0,189	0,531	1,126	0,146			
SA202	15	40	28,6	19,1	12	6,5	M6x1	4,8	13,5	28,6	3,7	9200	4480	0,10
SA202-9	5/8	1,5748	1,126	0,7520	0,4724	0,256	1/4-28UNF	0,189	0,531	1,126	0,146			
SA202-10	3/8													
SA203	17	40	28,6	19,1	12	6,5	M6x1	4,8	13,5	28,6	3,7	9200	4480	0,09
SA203-11	11/16	1,5748	1,126	0,7520	0,4724	0,256	1/4-28UNF	0,189	0,531	1,126	0,146			
SA204	20	47	31	21,5	14	7,5	M6x1	4,8	13,5	33,3	3,7	12200	6300	0,16
SA204-12	3/4	1,8504	1,220	0,8465	0,5512	0,295	1/4-28UNF	0,189	0,531	1,311	0,146			
SA205	25	52	31	21,5	15	7,5	M6x1	4,8	13,5	38,1	3,9	13300	7460	0,20
SA205-13	13/16	2,0472	1,220	0,8465	0,5906	0,295	1/4-28UNF	0,189	0,531	1,500	0,154			
SA205-14	7/8													
SA205-15	15/16													
SA205-16	1													
SA206	30	62	35,7	23,8	16	9	M8x1	6	15,9	44,5	5,0	18500	10800	0,30
SA206-17	11/16	2,4409	1,406	0,9370	0,6299	0,354	5/16-28UNF	0,236	0,626	1,752	0,197			
SA206-18	11/8													
SA206-19	13/16													
SA206-20	11/4													
SA207	35	72	38,9	25,4	17	9,5	M8x1	6,8	17,5	55,6	5,7	24500	14600	0,42
SA207-20	11/4	2,8346	1,531	1,000	0,6693	0,374	5/16-24UNF	0,268	0,689	2,189	0,224			
SA207-21	15/16													
SA207-22	13/8													
SA207-23	17/16													
SA208	40	80	43,7	30,2	18	11	M8x1	6,8	18,3	60,3	6,2	27700	17000	0,60
SA208-24	11/2	3,1496	1,721	1,1890	0,7087	0,433	5/16-24UNF	0,268	0,720	2,374	0,244			
SA208-25	13/16													
SA209	45	85	43,7	30,2	19	11	M8x1	6,8	18,3	63,5	6,4	31100	24450	0,76
SA209-26	15/8	3,3465	1,721	1,1890	0,7480	0,433	5/16-24UNF	0,268	0,720	2,500	0,252			
SA209-27	111/16													
SA209-28	13/4													
SA210	50	90	43,7	30,2	20	11	M8x1	6,8	18,3	69,9	6,5	35300	28160	0,91
SA210-29	113/16	3,5433	1,721	1,1890	0,7874	0,433	5/16-24UNF	0,268	0,720	2,752	0,256			
SA210-30	17/8													
SA210-31	115/16													
SA210-32	2													
SA211	55	100	48,4	32,5	21	12	M8x1	8	20,7	76,2	7,0	38100	30000	1,26
SA211-32	2	3,9370	1,906	1,2795	0,8268	0,472	5/16-24UNF	0,315	0,815	3,000	0,276			
SA211-33	21/16													
SA211-34	21/8													
SA211-35	23/16													
SA212	60	110	53,1	37,2	22	13,5	M10x1	8	22,3	84,2	7,6	41500	32730	1,70
SA212-36	21/4	4,3307	2,091	1,4646	0,8661	0,532	3/8-24UNF	0,315	0,878	3,315	0,299			
SA212-37	23/8													
SA212-38	23/4													
SA212-39	27/16													

Disponibile in acciaio inox AISI 440C o 420C - Available stainless steel AISI 440C or 420C

SB-RB2 Serie leggera - Light duty

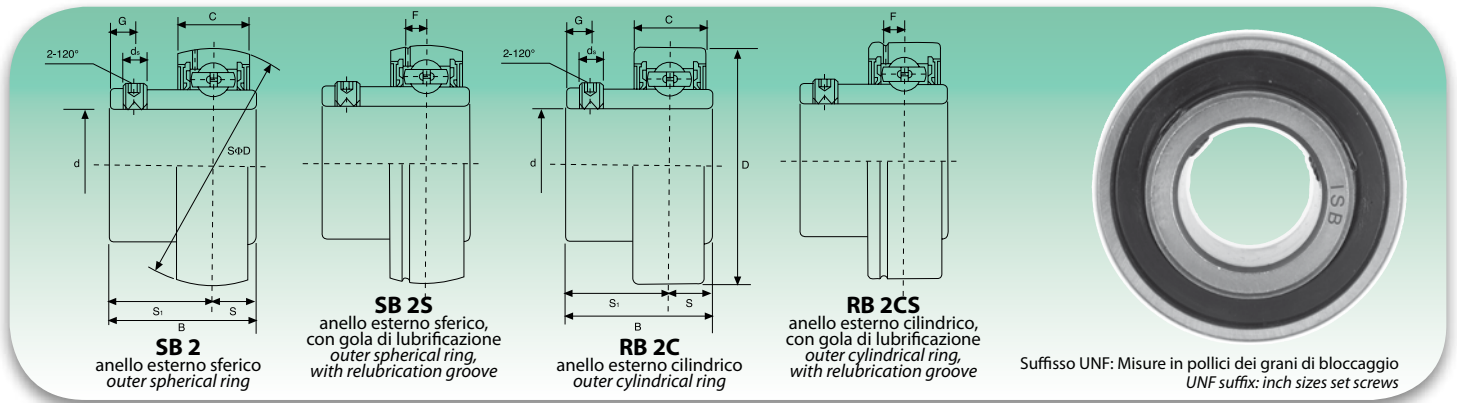

Tipo Type	Dimensioni - Dimensions									Coefficienti di carico (N) Load ratings (N)		Peso Weight kg
	d	D	B	C	S	S ₁	ds	G	F	Dinamico C Dynamic C	Statico C ₀ Static C ₀	
	mm/inch											
SB-RB201	12	40	22	12	6	16	M5x0,8	4,5	3,7	9200	4480	0,10
SB-RB201-8	3/4	1,5748	0,8661	0,4724	0,236	0,630	10-32UNF	0,177	0,146			
SB-RB202	15	40	22	12	6	16	M5x0,8	4,5	3,7	9200	4480	0,10
SB-RB202-9	9/16	1,5748	0,8661	0,4724	0,236	0,630	10-32UNF	0,177	0,146			
SB-RB202-10	5/8											
SB-RB203	17	40	22	12	6	16	M5x0,8	4,5	3,7	9200	4480	0,09
SB-RB203-11	1 1/16	1,5748	0,7520	0,4724	0,256	1/4-28UNF	0,189	0,531	0,146			
SB-RB204	20	47	25	14	7	18	M6x1	4,5	3,7	12200	6300	0,13
SB-RB204-12	3/4	1,8504	0,9843	0,5512	0,276	0,709	1/4-28UNF	0,177	0,146			
SB-RB205	25	52	27	15	7,5	19,5	M6x1	5,5	3,9	13300	7460	0,16
SB-RB205-13	1 3/16	2,0472	1,0630	0,5906	0,295	0,768	1/4-28UNF	0,217	0,154			
SB-RB205-14	7/8											
SB-RB205-15	1 1/16											
SB-RB205-16	1											
SB-RB206	30	62	30	16	8	22	M6x1	6	5,0	18500	10800	0,25
SB-RB206-17	1 1/16	2,4409	1,1811	0,6299	0,315	0,866	1/4-28UNF	0,236	0,197			
SB-RB206-18	1 1/8											
SB-RB206-19	1 3/16											
SB-RB206-20	1 1/4											
SB-RB207	35	72	32	17	8,5	23,5	M8x1	6,5	5,7	24500	14600	0,38
SB-RB207-20	1 1/4	2,8346	1,2598	0,6693	0,335	0,925	3/16-24UNF	0,256	0,224			
SB-RB207-21	1 5/16											
SB-RB207-22	1 3/8											
SB-RB207-23	1 7/16											
SB-RB208	40	80	34	18	9	25	M8x1	7	6,2	27700	17000	0,60
SB-RB208-24	1 1/2	3,1496	1,3386	0,7087	0,354	0,984	3/16-24UNF	0,276	0,244			
SB-RB208-25	1 3/16											
SB-RB209	45	85	41,2	19	10,2	31	M8x1	8,2	6,4	31100	24450	0,8
SB-RB209-26	1 5/8	3,3465	1,6220	0,7480	0,402	1,220	3/16-24UNF	0,323	0,252			
SB-RB209-27	1 11/16											
SB-RB209-28	1 3/4											
SB-RB210	50	90	43,5	20	10,9	32,6	M10x1	9,2	6,5	35300	28160	0,8
SB-RB210-29	1 13/16	3,5433	1,7126	0,7874	0,429	1,283	3/8-24UNF	0,362	0,256			
SB-RB210-30	1 7/8											
SB-RB210-31	1 15/16											
SB-RB210-32	2											
SB-RB211	55	100	45,3	21	11,8	33,5	M10x1	9,8	7,0	38100	30000	1,1
SB-RB211-32	2	3,9370	1,7835	0,8268	0,465	1,319	3/8-24UNF	0,386	0,276			
SB-RB211-33	2 1/16											
SB-RB211-34	2 1/8											
SB-RB211-35	2 3/16											
SB-RB212	60	110	53,7	22	14,9	38,8	M10x1	9,8	7,6	41500	32730	1,3
SB-RB212-36	2 1/4	4,3307	2,1142	0,8661	0,587	1,528	3/8-24UNF	0,386	0,299			
SB-RB212-37	2 3/16											
SB-RB212-38	2 3/8											
SB-RB212-39	2 1/2											

Disponibile in acciaio inox AISI 440C o 420C - Available stainless steel AISI 440C or 420C

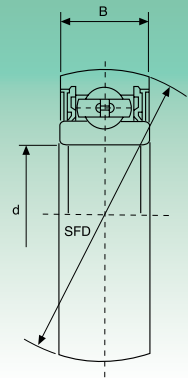

Tipo Type	Dimensioni - Dimensions			Coefficienti di carico (N) Load ratings (N)		Peso Weight kg
	d	D	B	Dinamico C Dynamic C	Statico C ₀ Static C ₀	
	mm/inch					
CB200	10	30	9	3750	2150	0,030
CB200	0,3937	1,1811	0,3543			
CB201	12	32	10	4500	2500	0,035
CB201	0,4724	1,2598	0,3937			
CB202	15	35	11	5650	3300	0,040
CB202	0,5906	1,3780	0,4331			
CB203	17	40	12	7000	4480	0,06
CB203	0,6693	1,5748	0,4724			
CB204	20	47	14	9880	6200	0,10
CB204	0,7874	1,8504	0,5512			
CB205	25	52	15	10780	6980	0,13
CB205	0,9843	2,0472	0,5906			
CB206	30	62	16	14970	10040	0,20
CB206	1,1811	2,4409	0,6299			
CB207	35	72	17	19750	13670	0,29
CB207	1,3780	2,8346	0,6693			
CB208	40	80	18	22710	15940	0,37
CB208	1,5748	3,1496	0,7087			
CB209	45	85	19	24360	17710	0,46
CB209	1,7717	3,3465	0,7480			
CB210	50	90	20	26980	19840	0,57
CB210	1,9685	3,5433	0,7874			
CB211	55	100	21	28500	21850	0,62
CB211	2,1654	3,9370	0,8268			
CB212	60	110	22	31700	24500	0,80
CB212	2,3622	4,3307	0,8661			

Equivalente serie 62.. bombato ISB® - Equivalent 62.. spherical ISB®

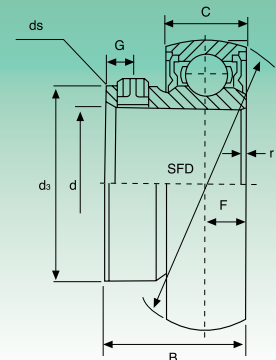

Tipo Type	Dimensioni - Dimensions									Coefficienti di carico (N) Load ratings (N)		Peso Weight kg
	d	D	B	C	d _s	F	G	r	d _s	Dinamico C Dynamic C	Statico C ₀ Static C ₀	
	mm/inch											
U000	10	26	14	8	14,75	4	3	0,5	M3	470	200	0,023
U000	0,3937	1,024	0,5512	0,3150	0,5807	1,1575	0,1181	0,0197				
U001	12	28	14,5	8	17,35	4	3	0,5	M3	520	245	0,027
U001	0,4724	1,1024	0,5709	0,3150	0,6831	1,1575	0,1181	0,0197				
U002	15	32	16,5	9	20,02	4,5	3,5	0,5	M4	570	290	0,045
U002	0,5906	1,2598	0,6496	0,3543	0,7882	0,1772	0,1378	0,0197				
U003	17	35	17,5	10	23,10	5	3,5	0,5	M4	610	335	0,050
U003	0,6693	1,3780	0,6890	0,3937	0,9094	0,1969	0,1378	0,0197				
U004	20	42	21	12	27,00	6	4	1	M5	955	515	0,086
U004	0,7874	1,6535	0,8268	0,4724	1,0630	0,2362	1,1575	0,0394				
U005	25	47	22,5	12	31,70	6	4,5	1	M5	1030	595	0,100
U005	0,9843	1,8504	0,8858	0,4724	1,2480	0,2362	0,1772	0,0394				
U006	30	55	24,5	13	38,00	6,5	5	1,5	M5	1350	845	0,145
U006	1,1811	2,1654	0,9646	0,5118	1,4961	0,2559	0,1969	0,0591				

Disponibile su richiesta in acciaio inox: AISI 440C o 420C - Available under request stainless steel: AISI 440C or 420C

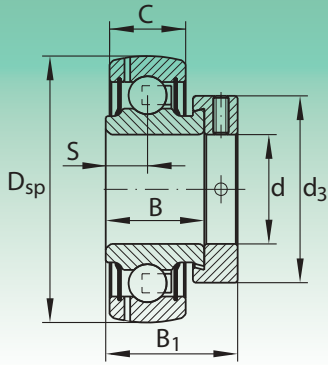

Tipo Type	Dimensioni - Dimensions							Coefficienti di carico Load ratings		Peso Weight
	d	Dsp	C	B	S	B1	d3 max	Dinamico Cr (kN) Dynamic Cr (kN)	Statico Cor (kN) Static Cor (kN)	
	mm									kg
GRAE 20 NPP-B	20	47	14	21,4	7,5	31	33	12,8	6,6	0,16
GRAE 25 NPP-B	25	52	15	21,4	7,5	31	37,5	14	7,8	0,19
GRAE 30 NPP-B	30	62	18	23,8	9	35,8	44	19,5	11,3	0,31
GRAE 35 NPP-B	35	72	19	25,4	9,5	39	51	25,5	15,3	0,48
GRAE 40 NPP-B	40	80	21	30,2	11	43,8	58	32,5	19,8	0,62
GRAE 45 NPP-B	45	85	22	30,2	11	43,8	63	32,5	20,4	0,69
GRAE 50 NPP-B	50	90	22	30,2	11	43,8	69	35	23,2	0,77
GRAE 55 NPP-B	55	100	25	32,5	12	48,4	76	43,5	29	0,81
GRAE 60 NPP-B	60	110	24	37,1	13,5	53,1	84	56	36	1,4

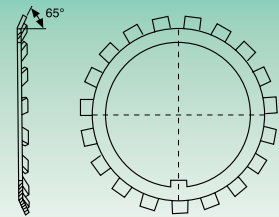
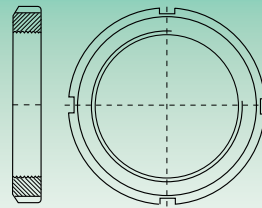
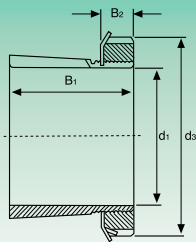

Tipo Type	Dimensioni - Dimensions				Bussola Sleeve	Ghiera di bloccaggio Lock nut	Rosetta Washer	Cuscinetto Bearing			Peso Weight			
	d ₁	B ₁	B ₂	d ₃				A...	KM	MB		Serie normale Normal duty	Serie media Medium duty	Serie pesante Heavy duty
	mm/inch													
H 2305	20	35	8	38	A 2305X	KM 05	MB 05	UK 205	UK X05	UK 305	0,087			
HE 2305	¾	1,3780	0,3150	1,4961	AE 2305X									
H 2306	25	38	8	45	A 2306X									
HS 2306	7/8	1,4961	0,3150	1,7717	AS 2306X	KM 06	MB 06	UK 206	UK X06	UK 306	0,126			
HA 2306	15/16				AA 2306X									
HE 2306	1				AE 2306X									
H 2307	30	43	9	52	A 2307X	KM 07	MB 07	UK 207	UK X07	UK 307	0,165			
HS 2307	1 1/8	1,6929	0,3543	2,0472	AS 2307X									
HA 2307	1 3/16				AA 2307X									
H 2308	35				46	10	58	A 2308X	KM 08	MB 08	UK 208	UK X08	UK 308	0,224
HE 2308	1 1/4	1,8110	0,3937	2,2835	AE 2308X									
HS 2308	1 3/8				AS 2308X									
H 2309	40				50	11	65	A 2309X	KM 09	MB 09	UK 209	UK X09	UK 309	0,280
HA 2309	1 7/16	1,9685	0,4331	2,5591	AA 2309X									
HE 2309	1 1/2				AS 2309X									
HS 2309	1 5/8				AS 2309X									
H 2310	45	55	12	70	A 2310X	KM 10	MB 10	UK 210	UK X10	UK 310	0,362			
HA 2310	1 11/16	2,1654	0,4724	2,7559	AA 2310X									
HE 2310	1 3/4				AE 2310X									
H 2311	50				59	12	75	A 2311X	KM 11	MB 11	UK 211	UK X11	UK 311	0,420
HS 2311	1 7/8	2,3228	0,4724	2,9528	AS 2311X									
HA 2311	1 15/16				AA 2311X									
HE 2311	2				AE 2311X									
H 2312	55	62	13	80	A 2312X	KM 12	MB 12	UK 212	UK X12	UK 312	0,480			
HS 2312	2 1/8	2,4409	0,5118	3,1496	AS 2312X									
H 2313	60				65							14	85	A 2313X
HA 2313	2 3/16				2,5591	0,5512	3,3465	AA 2313X						
HE 2313	2 1/4	AE 2313X												
HS 2313	2 3/8	AS 2313X												
H 2315	65	73	15	98	A 2315X	KM 15	MB 15	UK 215	UK X15	UK 315	1,05			
HE 2315	2 1/2	2,8740	0,5906	3,8583	AE 2315X									
HS 2315	2 5/8				AS 2315X									
H 2316	70				78	17	105	A 2316X	KM 16	MB 16	UK 216	UK X16	UK 316	1,28
HE 2316	2 3/4	3,0709	0,6693	4,1339	AE 2316X									
H 2317	75				82	18	110	A 2317X						
HS 2317	2 7/8				3,2283	0,7087	4,3307	AS 2317X						
HA 2317	2 15/16	AA 2317X												
HE 2317	3	AE 2317X												
H 2318	80	86	18	120	A 2318X	KM 18	MB 18	UK 218	UK X18	UK 318	1,70			
HA 2318	3 1/16	3,3858	0,7087	4,7244	AA 2318X									
H 2319	85				90							19	125	A 2319X
HE 2319	3 1/4				3,5433	0,7480	4,9213	AE 2319X						
H 2320	90	97	20	130				A 2320X	KM 20	MB 20	-	UK X20	UK 320	2,15
HE 2320	3 1/2	3,8189	0,7874	5,1181				AE 2320X						
H 2322	100				105	21	145	A 2322X						
HE 2322	4				4,1339	0,8268	5,7087	AE 2322X						
H 2324	110	112	22	155				A 2324X	KM 24	MB 24	-	-	UK 324	3,20
HA 2324	4 7/16	4,4094	0,8661	6,1024				AA 2324X						
H 2326	115				121	23	165	A 2326X						
HE 2326	4 1/2				4,7638	0,9055	6,4961	AE 2326X						
H 2328	125	131	24	180				A 2328X	KM 28	MB 28	-	-	UK 328	5,52
HA 2328	4 15/16	5,1575	0,9449	7,0866				AA 2328X						
HE 2328	5 1/8				AE 2328X									



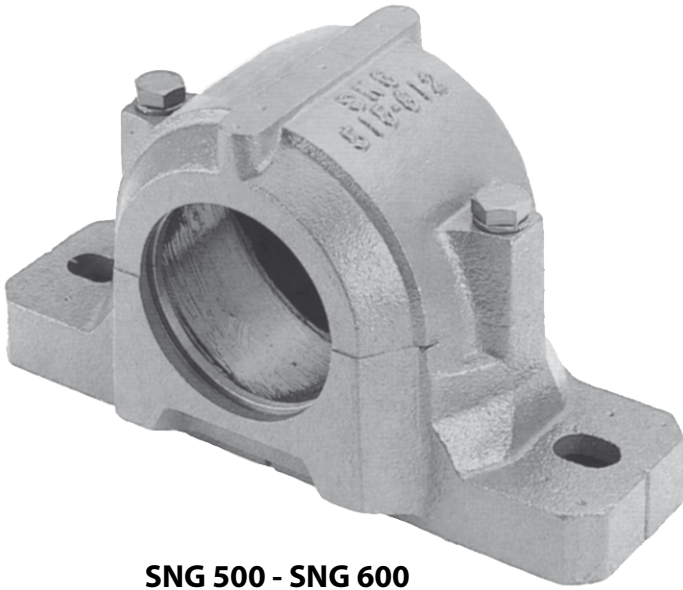

SNG 500 - SNG 600

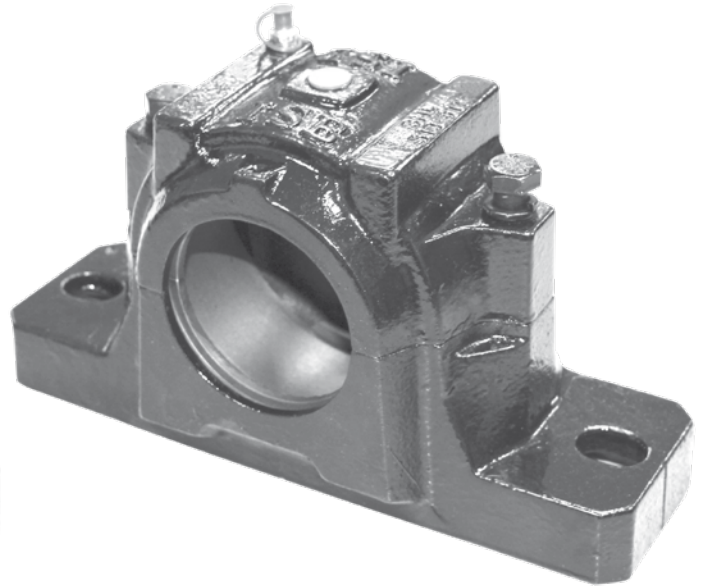

SNL 500

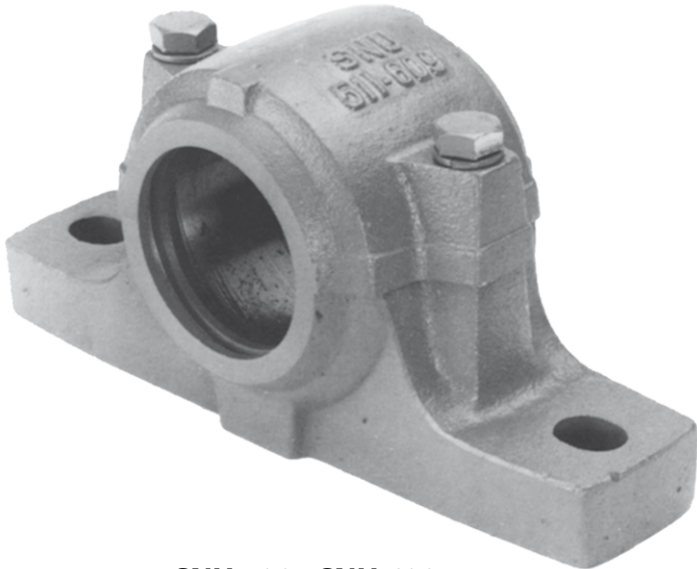

**SNU 500 - SNU 600
SNA 500 - SNA 600**



**SN 500 - SN 600
SN 200 - SN 300**

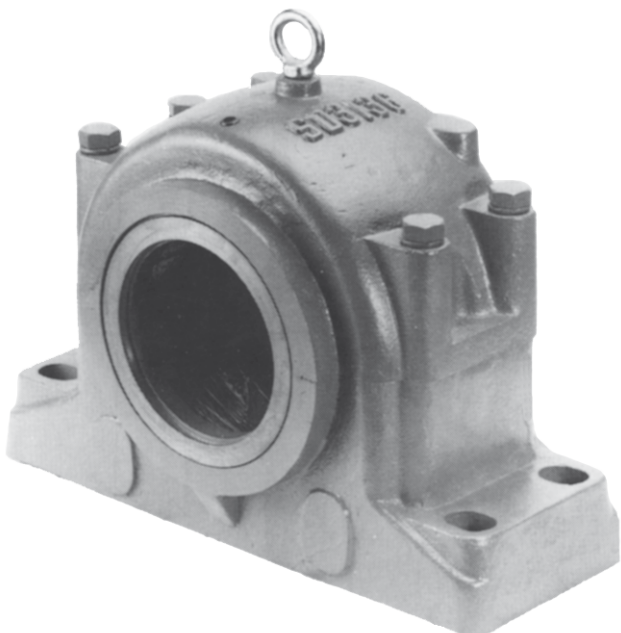

SD 3100

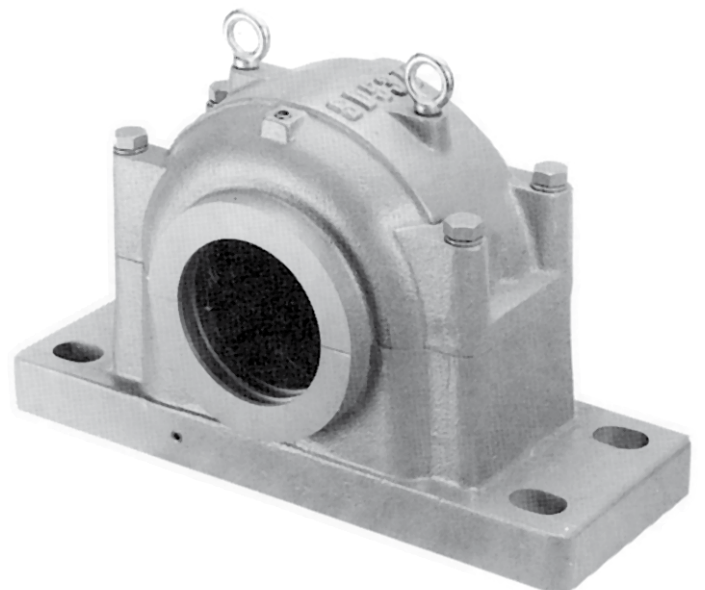

SD 3000

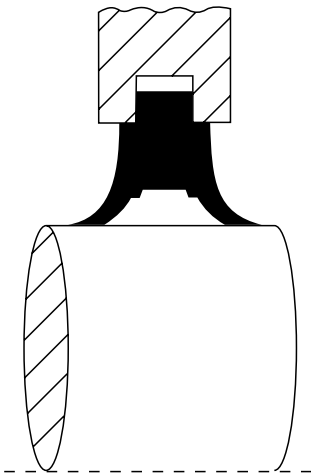

Tenuta in poliuretano "TSNG" per: SNG-SNU
 "TSNG" polyurethan seal for: SNG-SNU

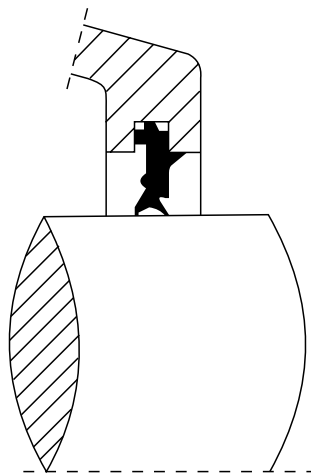

Tenuta in gomma "TSNU" per: SNG-SNU
 "TSNU" rubber seal for: SNG-SNU

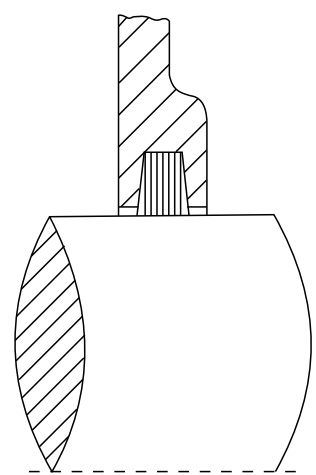

Tenuta in feltro "TSNC" per: SNG-SNU
 "TSNC" felt seal for: SNG-SNU

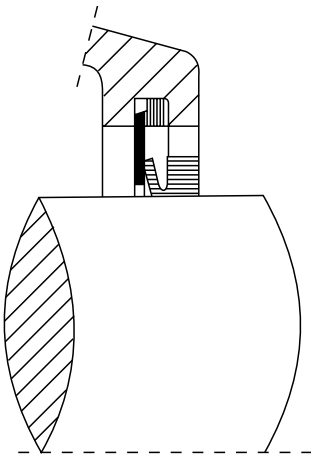

Tenuta v-ring "TSNA" per: SNG-SNU
 "TSNA" v-ring seal for: SNG-SNU

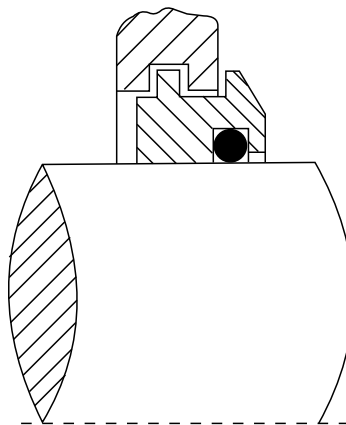

Tenuta a labirinto "TSNS" per: SNG-SNU
 "TSNS" labyrinth seal for: SNG-SNU

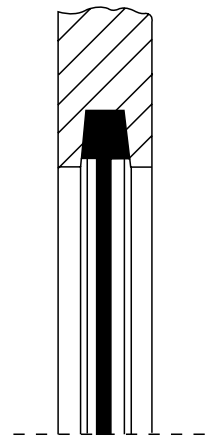

Coperchio di chiusura "A" per: SNG-SNU-SN
 "A" end cover for: SNG-SNU-SN

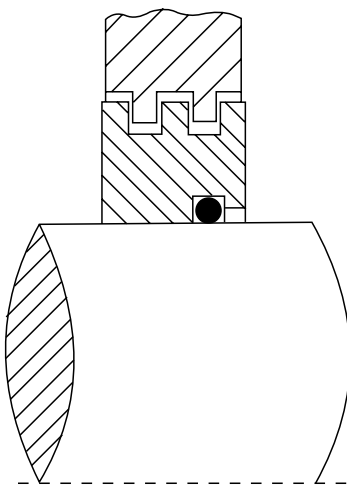

Tenuta a labirinto "TS" per: SN-SD
 "TS" labyrinth seal for: SN-SD

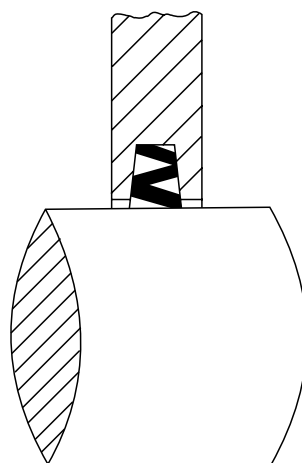

Tenuta in NBR "ZF" per: SN
 "ZF" NBR seals for: SN

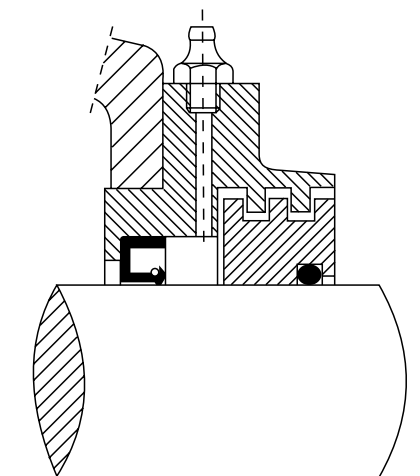

Chiusura di taconite "TAC" per: SN-SD
 "TAC" taconite cover for: SN-SD

A
MATERIALI - MATERIALS:
1
SEDE - HOUSING:

Materiale Material	Carico di rottura Tensile strength kgf/mm ²	Carico di snervamento Yield strength kgf/mm ²	Allungamento Elongation	Codice Jis Jis code	Codice USA U.S. code
GHISA CAST IRON	20	-	-	G 5501 (FC 200)	ASTM A 48 GRADO/GRADE 35
ACCIAIO DUTILE DUCTILE IRON (S. G.)	45	30	10%	G 5502 (FCD 450)	ASTM A 536 GRADO/GRADE 65-45-12

2
ACCESSORI - ACCESSORIES:

Dispositivi di chiusura Sealing arrangements	Sigla Ref.	Per For	Materiali Materials
TENUTA IN POLIURETANO POLYURETHAN SEAL	TSNG	SNG-SNU	Poliuretano Polyurethan
TENUTA IN GOMMA U-LOCK RUBBER SEAL	TSNU	SNG-SNU	Gomma Rubber
TENUTA IN FELTRO FELT SEAL	TSNC	SNG-SNU	Feltro Felt
TENUTA V-RING V-RING SEAL	TSNA	SNG-SNU	NBR NBR
TENUTA LABIRINTO LABYRINTH SEAL	TSNS	SNG-SNU	Ghisa Cast iron
COPERCHIO DI CHIUSURA END COVER	A	SNG-SNU-SN	NBR e lamiera in acciaio NBR and Carbon steel platè
TENUTA LABIRINTO LABYRINTH SEAL	TS	SN-SD	Ghisa Cast iron
CHIUSURA DI TACONITE TACONITE COVER TAC	TAC	SD	Ghisa Cast iron

3
TOLLERANZE - TOLERANCES:

(mm.)

	Dimensioni - Dimensions	Tolleranze - Tolerances
		1-100
TOLLERANZA DELLA FUSIONE CASTING TOLERANCE	100-200	± 2,0
	200-400	± 3,0
	400-800	± 4,0
	800-1600	± 5,0

TOLLERANZE DI LAVORAZIONE - MACHINE TOLERANCES

1

DIAMETRO DEL FORO (D) - BORE DIAMETER (D)

(µm)

Diametro del foro (mm) Bore diameter (mm)	G7	H7	H8	J7
10-18	+24 +26	-18 -0	+27 -0	+10 -8
18-30	+28 +7	+21 -0	+33 -0	+12 -9
30-50	+34 +9	+25 -0	+39 -0	+14 -11
50-80	+40 +10	+30 -0	+46 -0	+18 -12
80-120	+42 +12	+35 -0	+54 -0	+22 -13
120-180	+54 +14	+40 -0	+63 -0	+26 -14
180-250	+61 +15	+46 -0	+72 -0	+30 -16
250-315	+69 +17	+52 -0	+81 -0	+36 -16
315-400	+75 +18	+57 -0	+89 -0	+39 -18
400-500	+83 +20	+63 -0	+97 -0	+43 -20
500-620	+92 +23	+69 -0	+104 -0	+46 -23

2

ALTRE TOLLERANZE, ECCETTO FORO (D) - OTHER TOLERANCES, EXCEPT BORE (D)

(µm)

Diametro del foro (mm) Bore diameter (mm)	js11	H12	H13	h12	h13
18-30	±65	+210 -0	+330 -0	+0 -210	+0 -330
30-50	±80	+250 -0	+390 -0	+0 -250	+0 -390
50-80	±95	+300 -0	+460 -0	+0 -300	+0 -460
80-120	±110	+350 -0	+540 -0	+0 -350	+0 -540
120-180	±125	+400 -0	+630 -0	+0 -400	+0 -630
180-250	±145	+460 -0	+720 -0	+0 -460	+0 -720
250-315	±160	+520 -0	+810 -0	+0 -520	+0 -810
315-400	±180	+570 -0	+890 -0	+0 -570	+0 -890

3

TOLLERANZE SUGGERITE PER SEDE CUSCINETTO - RECOMMENDED FITS OF BEARING HOUSING TOLERANCES

SUPPORTO UNICO O IN DUE PEZZI SPLIT OR SOLID HOUSING	Condizioni di carico Load conditions		Esempio di riferimento Reference example	Tolleranze Tolerances	Anello esterno Outer ring
	Direzione di carico non determinate Direction of load indeterminate	Carico normale e leggero Normal and light load	Motori elettrici, pompe Electric motors, pumps	J7	Possibilità di spostamento Can be displaced
Carico dell'anello interno rotante Rotating inner ring load	Carichi di tutti i tipi Loads of a kinds	Applicazioni generali di cuscinetti e boccole Bearings and bushes general applications	H7	Possibilità di facile spostamento Can easily be displaced	
Carico dell'anello interno rotante Rotating inner ring load	Carico leggero e normale Normal and light load	Supporti Plummer blocks	H8	Possibilità di facile spostamento Can easily be displaced	
Carico dell'anello interno rotante Rotating inner ring load	Incremento della temperatura dell'anello interno attraverso l'albero High temperature rise of inner ring through shaft	Essiccatoi per carta Paper dryers	J7	Possibilità di facile spostamento Can easily be displaced	

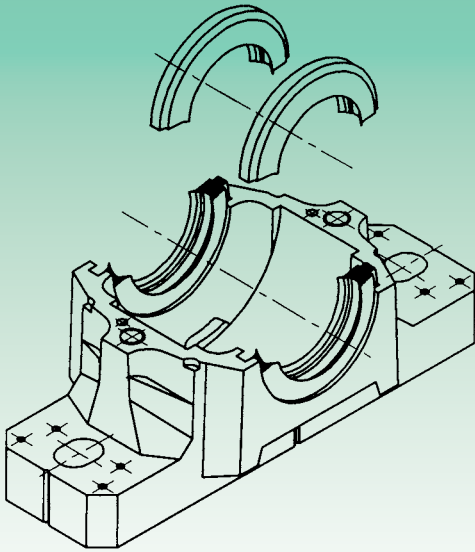

TENUTE "TSNG" SIA PER ALBERI METRICI CHE IN POLLICI
 "TSNG" SEALS FIT BOTH METRIC & INCHES SHAFTS

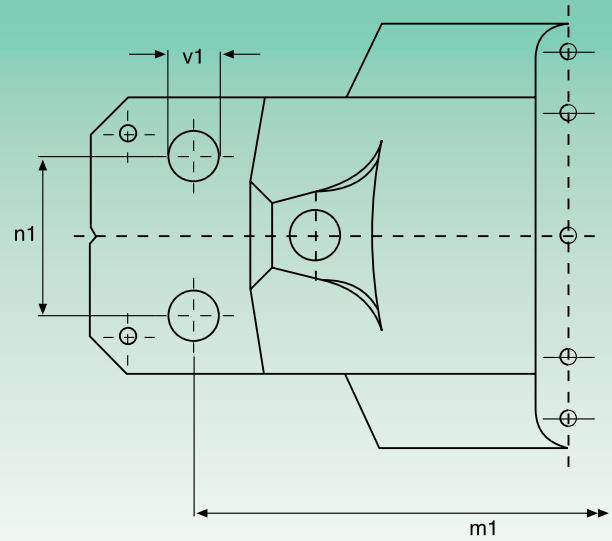

DISPONIBILE PER MONTAGGIO A QUATTRO-FORI
 AVAILABLE FOR FOUR-BOLT MOUNTING

Tipo Type	m1	n1	v1	Bull. fiss. Bolt Size	Tenuta Seal	Diametro albero Shaft diameter			Tenuta Seal	Diametro albero Shaft diameter		
						mm	inch	mm		inch		
SNG 507-606D	-	-	-	-	TSNG 507	30	1 1/8	1 3/16	TSNG 607	30	1 1/8	1 3/16
SNG 508-607D	160	34	11	M10	TSNG 508	35	1 5/16	1 3/8	TSNG 608	35	1 5/16	1 3/8
SNG 509D	160	34	11	M10	TSNG 509	40	1 1/2	1 5/16	TSNG 609	40	1 1/2	1 5/16
SNG 510-608D	160	34	11	M10	TSNG 510	45	1 7/16	1 3/4	TSNG 610	45	1 7/16	1 3/4
SNG 511-609D	200	40	14	M12	TSNG 511	50	1 9/16	2	TSNG 611	50	1 9/16	2
SNG 512-610D	200	40	14	M12	TSNG 512	55	2 1/8	2 3/16	TSNG 612	55	2 1/8	2 3/16
SNG 513-611D	220	48	14	M12	TSNG 513	60	2 1/4	2 5/16	TSNG 613	60	2 1/4	2 5/16
SNG 515-612D	220	48	14	M12	TSNG 515	65	2 5/16	2 1/2	TSNG 615	65	2 5/16	2 1/2
SNG 516-613D	252	52	18	M16	TSNG 516	70	2 7/16	2 3/4	TSNG 616	70	2 7/16	2 3/4
SNG 517D	252	52	18	M16	TSNG 517	75	2 9/16	3	TSNG 617	75	2 9/16	3
SNG 518-615D	280	58	18	M16	TSNG 518	80	3 1/16	3 1/4	TSNG 618	80	3 1/16	3 1/4
SNG 519-616D	280	58	18	M16	TSNG 519	85	3 3/16	3 3/8	TSNG 619	85	3 3/16	3 3/8
SNG 520-617D	300	66	18	M16	TSNG 520	90	3 5/16	3 1/2	TSNG 620	90	3 5/16	3 1/2
SNG 522-619D	320	74	18	M16	TSNG 522	100	3 9/16	4	-	-	-	-
SNG 524-620D	330	74	18	M16	TSNG 524	110	4 3/16	4 1/4	-	-	-	-
SNG 526D	370	80	22	M20	TSNG 526	115	4 7/16	4 1/2	-	-	-	-
SNG 528D	400	92	26	M24	TSNG 528	125	4 9/16	5	-	-	-	-
SNG 530D	430	100	26	M24	TSNG 530	135	5 3/16	5 1/4	-	-	-	-
SNG 532D	450	100	26	M24	TSNG 532	140	5 7/16	5 1/2	-	-	-	-

INTERCAMBIABILE CON SUPPORTI SNH, SNU, SNA.
INTER-EXCHANGEABLE WITH PLUMMER BLOCKS SNH, SNU, SNA.

Possibilità di scelta per collocazione ingrassatori ed oliatori
Various choice of oil/grease locations

Punzonature per eventuale applicazione di perni di riferimento
Dimples provider for locating pins if required

Molteplici zone per l'installazione di sensori
Various sensor/monitor installing spaces

Cavità previste per smontaggio supporto
Gaps provider to help splitting the housings

Base rinforzata per carichi pesanti
Reinforced base for heavy load

Linee di riferimento centrali per facilitare l'allineamento nel montaggio
Cross center lines for easy alignment in assembly

Otto locazioni selezionate per il drenaggio
Eight location selected for drainage

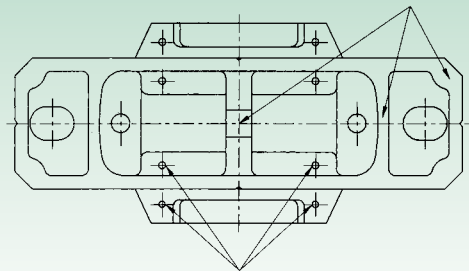
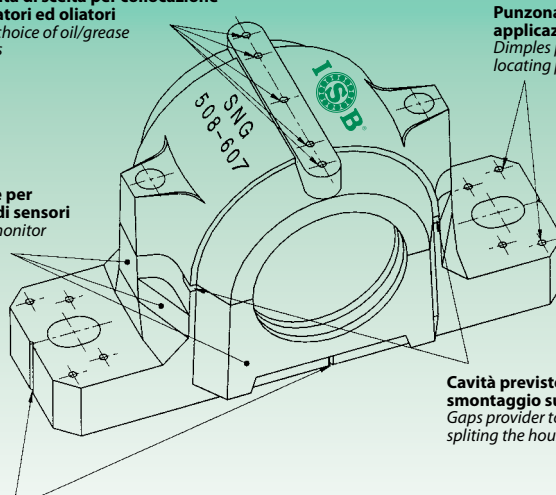

CARICHI DI ROTTURA - BREAKING LOADS

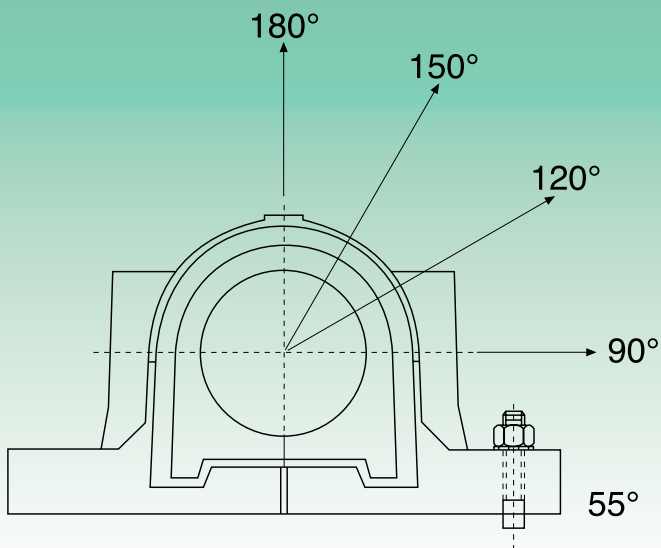

Tipo Type	Carichi di rottura - Breaking loads						
	P ₀	P ₅₅	P ₉₀	P ₁₂₀	P ₁₅₀	P ₁₆₀	P _{assiale axial}
	kN						
SNG 205-505	100	155	95	70	60	80	52
SNG 206-305-506-605	130	170	100	80	65	85	55
SNG 207-507-606	140	190	115	85	80	95	60
SNG 208-307-508-607	150	215	130	95	85	110	70
SNG 209-509	160	230	140	100	90	115	75
SNG 210-510-608	170	265	155	120	110	130	85
SNG 211-511-609	190	275	170	125	115	140	90
SNG 212-512-610	210	300	180	130	120	150	100
SNG 213-513-611	270	340	205	150	130	170	110
SNG 215-515-612	290	410	250	185	160	205	135
SNG 216-516-613	350	430	260	190	175	215	140
SNG 217-517	370	480	290	205	190	240	155
SNG 218-518-615	430	550	340	250	215	275	180
SNG 519-616	-	580	350	260	230	290	190
SNG 520-617	-	620	370	280	250	310	200
SNG 522-619	-	680	410	310	275	340	220
SNG 524-620	-	790	470	350	320	400	260
SNG 526	-	900	540	410	360	450	295
SNG 528	-	1050	630	470	430	530	345
SNG 530	-	1200	730	540	480	600	390
SNG 532	-	1450	860	640	570	720	470

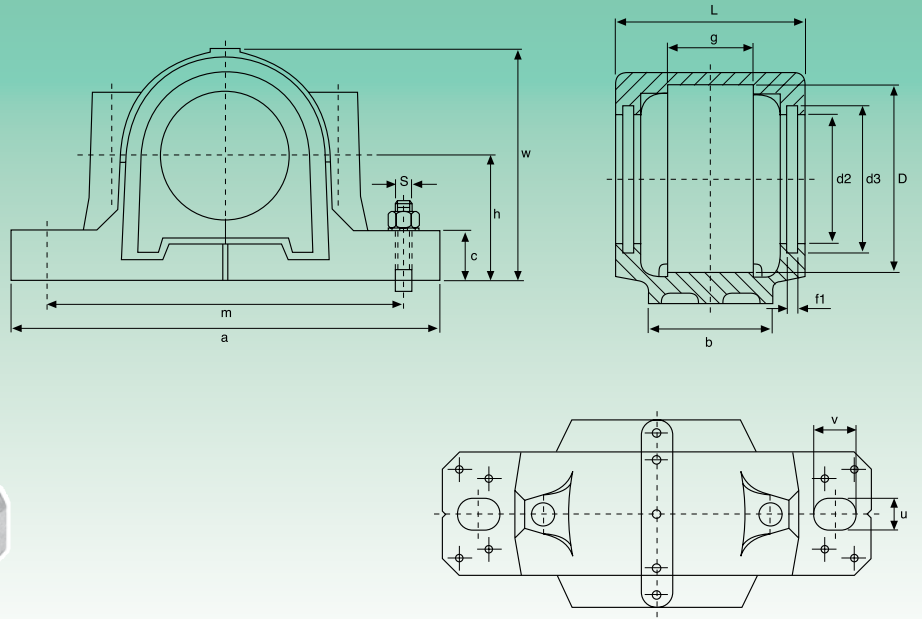
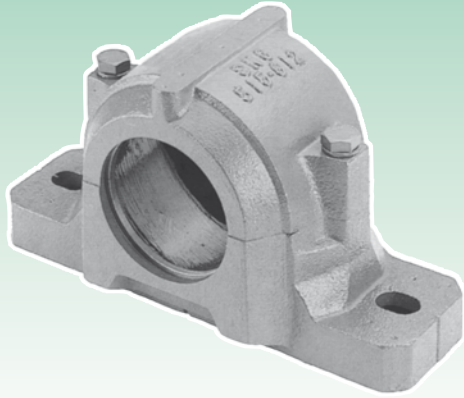

Tipo Type	Diametro albero Shaft diameter		Dimensioni - Dimensions														Bull. fiss. Bolt Size	
			D H8	a	b	c	g H12	h	L	w	m	U	V	d2 H12	d3 H12	f1	S	
	mm	inch	mm/inch															
SNG 505	20	¾	52	165	46	19	25	40	67	71	130	13	20	31,5	39,5	5	M8x35	
SNG 506-605	25	1⅞	1	62	185	52	22	32	50	77	87	150	13	22	36,5	44,5	5	M8x40
SNG 507-606	30	1⅞	1⅜	72	185	52	22	34	50	82	92	150	15	20	46,5	54,5	5	M10x45
SNG 508-607	35	1⅞	1⅝	80	205	60	25	39	60	85	106	170	15	20	51,5	59,5	5	M10x45
SNG 509	40	1½	1⅞	85	205	60	25	30	60	85	109	170	15	20	56,5	64,5	5	M10x50
SNG 510-608	45	1⅞	1¾	90	205	60	25	41	60	90	112	170	15	20	62	70,5	5	M10x50
SNG 511-609	50	1⅞	2	100	255	70	28	44	70	95	127	210	18	23	67	75,5	5	M12x60
SNG 512-610	55	2⅞	2⅞	110	255	70	30	48	70	105	133	210	18	23	72	80,5	5	M12x60
SNG 513-611	60	2¼	2⅞	120	275	80	30	51	80	110	148	230	18	24	77	85,5	5	M12x60
SNG 515-612	65	2⅞	2½	130	280	80	30	56	80	115	154	230	18	26	87	95,5	5	M12x70
SNG 516-613	70	2⅞	2¾	140	315	90	32	58	95	120	175	260	22	29	92,5	101	5	M16x80
SNG 517	75	2⅞	3	150	320	90	32	61	95	125	181	260	22	30	97,5	106	5	M16x80
SNG 518-615	80	3⅞	3¼	160	345	100	35	65	100	140	192	290	22	27	102,5	111	5	M16x80
SNG 519-616	85	3⅞	3⅞	170	345	100	35	68	112	145	209	290	22	27	131	141	6	M16x90
SNG 520-617	90	3⅞	3½	180	380	110	40	70	112	160	215	320	26	32	137,5	147,5	6	M20x90
SNG 522-619	100	3⅞	4	200	410	120	45	80	125	175	239	350	26	32	147,5	157,5	6	M20x100
SNG 524-620	110	4⅞	4¼	215	410	120	45	86	140	185	271	350	26	32	157,5	167,5	6	M20x110
SNG 526	115	4⅞	4½	230	445	130	50	90	150	190	290	380	28	35	167,5	177,5	6	M24x120
SNG 528	125	4⅞	5	250	500	150	50	98	150	205	302	420	35	42	177,5	187,5	6	M24x130
SNG 530	135	5⅞	5¼	270	530	160	60	106	160	220	323	450	35	42	192,5	202,5	6	M24x130
SNG 532	140	5⅞	5½	290	550	160	60	114	170	235	344	470	35	42	202,5	212,5	6	M24x130

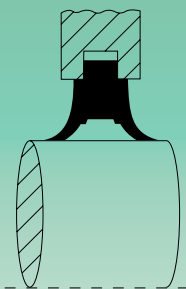

Tenuta in poliuretano "TSNG" per: SNG-SNU
"TSNG" polyurethan seal for: SNG-SNU

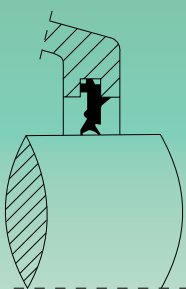

Tenuta in gomma "TSNU" per: SNG-SNU
"TSNU" rubber seal for: SNG-SNU

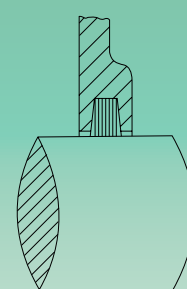

Tenuta in feltro "TSNC" per: SNG-SNU
"TSNC" felt seal for: SNG-SNU

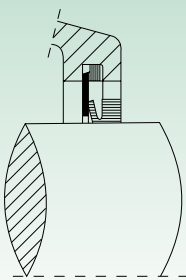

Tenuta v-ring "TSNA" per: SNG-SNU
"TSNA" v-ring seal for: SNG-SNU

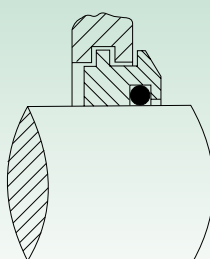

Tenuta a labirinto "TSNS" per: SNG-SNU
"TSNS" labyrinth seal for: SNG-SNU

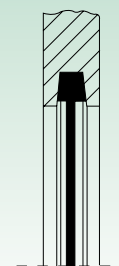

Coperchio di chiusura "A" per: SNG-SNU-SN
"A" end cover for: SNG-SNU-SN

Cuscinetto orientabile a sfere (foro conico) Self-aligning ball bearing (conical bore)	Cuscinetto orientabile a rulli (foro conico) Self-aligning roller bearing (conical bore)	Bussola (metrica) Adapter sleeve (metric)	Anello di centraggio Locating ring		Peso Weight kg	"TSNG" Tenuta in poliuretano Polyurethan seal	"TSNU" Tenuta in gomma Rubber seal	"TSNC" Tenuta in feltro Felt seal	"TSNA" Tenuta V-Ring V-Ring seal	"TSNS" Tenuta a labirinto Labyrinth seal	"A" Coperchio di chiusura End cover	Tipo Type
			Tipo Type	Q.tà Q.ty								
1205 K	-	H 205	SR 52x5	2	2,1	TSNG 505	TSNU 505	TSNC 505	TSNA 505	TSNS 505	A 505	SNG 505
2205 K	22205 K	H 305	SR 52x3,5	2								
1206 K	-	H 206	SR 62x8	2	2,4	TSNG 506	TSNU 506	TSNC 506	TSNA 506	TSNS 506	A 506-605	SNG 506-605
2206 K	22206 K	H 306	SR 62x6	2								
1207 K	-	H 207	SR 72x8,5	2	2,2	TSNG 507	TSNU 507	TSNC 507	TSNA 507	TSNS 507	A 507-606	SNG 507-606
2207 K	22207 K	H 307	SR 72x5,5	2								
1208 K	-	H 208	SR 80x10,5	2	2,8	TSNG 508	TSNU 508	TSNC 508	TSNA 508	TSNS 508	A 508-607	SNG 508-607
2208 K	22208 K	H 308	SR 80x8	2								
1209 K	-	H 209	SR 85x5,5	2	3,0	TSNG 509	TSNU 509	TSNC 509	TSNA 509	TSNS 509	A 509	SNG 509
2209 K	22209 K	H 309	SR 85x7	1								
		H 309	SR 85x3,5	2								
1210 K	-	H 210	SR 90x10,5	2	3,1	TSNG 510	TSNU 510	TSNC 510	TSNA 510	TSNS 510	A 510-608	SNG 510-608
2210 K	22210 K	H 310	SR 90x9	2								
1211 K	-	H 211	SR 100x11,5	2	4,5	TSNG 511	TSNU 511	TSNC 511	TSNA 511	TSNS 511	A 511-609	SNG 511-609
2211 K	22211 K	H 311	SR 100x9,5	2								
1212 K	-	H 212	SR 110x13	2	5,0	TSNG 512	TSNU 512	TSNC 512	TSNA 512	TSNS 512	A 512-610	SNG 512-610
2212 K	22212 K	H 312	SR 110x10	2								
1213 K	-	H 213	SR 120x14	2	6,1	TSNG 513	TSNU 513	TSNC 513	TSNA 513	TSNS 513	A 513-611	SNG 513-611
2213 K	22213 K	H 313	SR 120x10	2								
1215 K	-	H 215	SR 130x15,5	2	6,5	TSNG 515	TSNU 515	TSNC 515	TSNA 515	TSNS 515	A 515-612	SNG 515-612
2215 K	22215 K	H 315	SR 130x12,5	2								
1216 K	-	H 216	SR 140x16	2	9,0	TSNG 516	TSNU 516	TSNC 516	TSNA 516	TSNS 516	A 516-613	SNG 516-613
2216 K	22216 K	H 316	SR 140x12,5	2								
1217 K	-	H 217	SR 150x16,5	2	10,2	TSNG 517	TSNU 517	TSNC 517	TSNA 517	TSNS 517	A 517	SNG 517
2217 K	22217 K	H 317	SR 150x12,5	2								
1218 K	-	H 218	SR 160x17,5	2	12,4	TSNG 518	TSNU 518	TSNC 518	TSNA 518	TSNS 518	A 518-615	SNG 518-615
2218 K	22218 K	H 318	SR 160x12,5	2								
	23218 K	H 2318	SR 160x12,5	1								
1219 K	-	H 219	SR 170x18	2	13,5	TSNG 519	TSNU 519	TSNC 519	TSNA 519	TSNS 519	A 519-616	SNG 519-616
2219 K	22219 K	H 319	SR 170x12,5	2								
1220 K	22220 K	H 320	SR 180x12	2	17,5	TSNG 520	TSNU 520	TSNC 520	TSNA 520	TSNS 520	A 520-617	SNG 520-617
2220 K	23220 K	H 2320	SR 180x9,7	1								
1222 K	22222 K	H 322	SR 200x13,5	2	20,5	TSNG 522	TSNU 522	TSNC 522	TSNA 522	TSNS 522	A 522-619	SNG 522-619
2222 K	23222 K	H 2322	SR 200x10	1								
1224 K	22224 K	H 3124	SR 215x14	2	25,5	TSNG 524	TSNU 524	TSNC 524	TSNA 524	TSNS 524	A 524-620	SNG 524-620
		H 2324	SR 215x10	1								
		H 2324	SR 215x5	2								
	22226 K	H 3126	SR 230x13	2	33,0	TSNG 526	TSNU 526	TSNC 526	TSNA 526	TSNS 526	A 526	SNG 526
	23226 K	H 2326	SR 230x10	1								
	22228 K	H 3128	SR 250x15	2	42,0	TSNG 528	TSNU 528	TSNC 528	TSNA 528	TSNS 528	A 528	SNG 528
	23228 K	H 2328	SR 250x10	1								
	22230 K	H 3130	SR 270x16,5	2	53,0	TSNG 530	TSNU 530	TSNC 530	TSNA 530	TSNS 530	A 530	SNG 530
	23230 K	H 2330	SR 270x10	1								
	22232 K	H 3132	SR 290x17	2	55,0	TSNG 532	TSNU 532	TSNC 532	TSNA 532	TSNS 532	A 532	SNG 532
	23232 K	H 2332	SR 290x10	1								

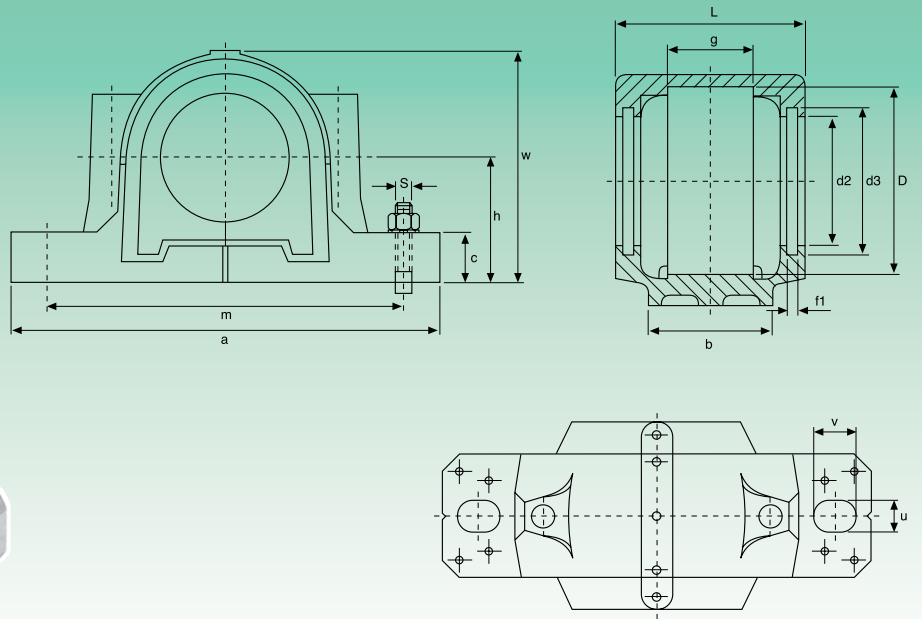
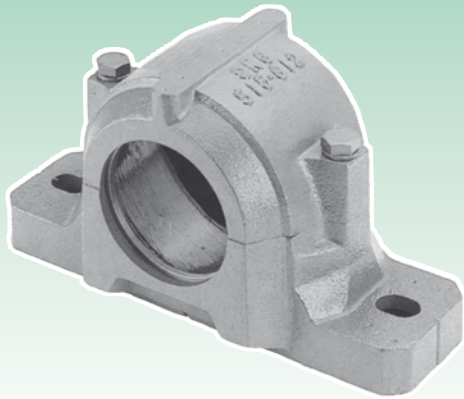

Tipo Type	Diametro albero Shaft diameter			Dimensioni - Dimensions													Bull. fiss. Bolt Size	
				D H8	a	b	c	g H12	h	L	w	m	U	V	d2 H12	d3 H12	f1	S
	mm	inch		mm/inch														
SNG 508-607	30	1 $\frac{1}{8}$	1 $\frac{3}{16}$	80	205	60	25	39	60	85	106	170	15	20	51,5	59,5	5	M10x45
SNG 510-608	35	1 $\frac{5}{16}$	1 $\frac{3}{8}$	90	205	60	25	41	60	90	112	170	15	20	62	70,5	5	M10x50
SNG 511-609	40	1 $\frac{1}{2}$	1 $\frac{9}{16}$	100	255	70	28	44	70	95	127	210	18	23	67	75,5	5	M12x60
SNG 512-610	45	1 $\frac{7}{16}$	1 $\frac{3}{4}$	110	255	70	30	48	70	105	133	210	18	23	72	80,5	5	M12x60
SNG 513-611	50	1 $\frac{5}{8}$	2	120	275	80	30	51	80	110	148	230	18	24	77	85,5	5	M12x60
SNG 515-612	55	2 $\frac{1}{8}$	2 $\frac{3}{16}$	130	280	80	30	56	80	115	154	230	18	26	87	95,5	5	M12x70
SNG 516-613	60	2 $\frac{1}{4}$	2 $\frac{5}{16}$	140	315	90	32	58	95	120	175	260	22	29	92,5	101	5	M16x80
SNG 518-615	65	2 $\frac{5}{16}$	2 $\frac{1}{2}$	160	345	100	35	65	100	140	192	290	22	27	102,5	111	5	M16x80
SNG 519-616	70	2 $\frac{7}{16}$	2 $\frac{3}{4}$	170	345	100	35	68	112	145	209	290	22	27	131	141	6	M16x90
SNG 520-617	75	2 $\frac{9}{16}$	3	180	380	110	40	70	112	160	215	320	26	32	137,5	147,5	6	M20x90
SNG 522-619	85	3 $\frac{3}{16}$	3 $\frac{3}{8}$	200	410	120	45	80	125	175	239	350	26	32	147,5	157,5	6	M20x100
SNG 524-620	90	3 $\frac{7}{16}$	3 $\frac{1}{2}$	215	410	120	45	86	140	185	271	350	26	32	157,5	167,5	6	M20x110

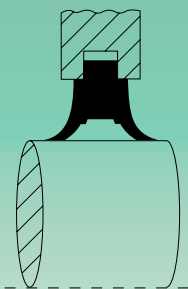

Tenuta in poliuretano "TSNG" per: SNG-SNU
"TSNG" polyurethan seal for: SNG-SNU

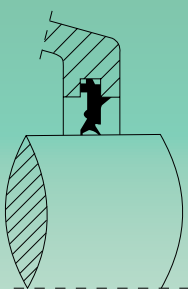

Tenuta in gomma "TSNU" per: SNG-SNU
"TSNU" rubber seal for: SNG-SNU

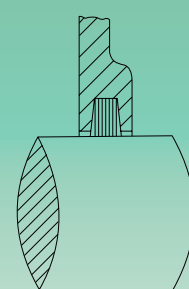

Tenuta in feltro "TSNC" per: SNG-SNU
"TSNC" felt seal for: SNG-SNU

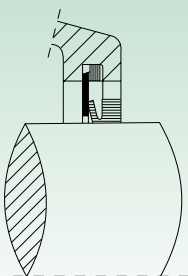

Tenuta v-ring "TSNA" per: SNG-SNU
"TSNA" v-ring seal for: SNG-SNU

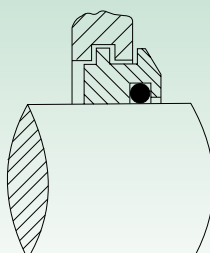

Tenuta a labirinto "TSNS" per: SNG-SNU
"TSNS" labyrinth seal for: SNG-SNU

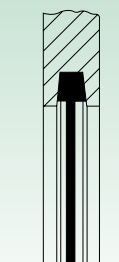

Coperchio di chiusura "A" per: SNG-SNU-SN
"A" end cover for: SNG-SNU-SN

Cuscinetto orientabile a sfere (foro conico) Self-aligning ball bearing (conical bore)	Cuscinetto orientabile a rulli (foro conico) Self-aligning roller bearing (conical bore)	Bussola (metrica) Adapter sleeve (metric)	Anello di centraggio Locating ring		Peso Weight kg	"TSNG" Tenuta in poliuretano Polyurethan seal	"TSNU" Tenuta in gomma Rubber seal	"TSNC" Tenuta in feltro Felt seal	"TSNA" Tenuta V-Ring V-Ring seal	"TSNS" Tenuta a labirinto Labyrinth seal	"A" Coperchio di chiusura End cover	Tipo Type
			Tipo Type	Q.tà Q.ty								
1307 K	-	H 307	SR 80x9	2	2,8	TSNG 607	TSNU 607	TSNC 607	TSNA 607	TSNS 607	A 508-607	SNG 508-607
2307 K	-	H 2307	SR 80x8	1								
1308 K	21308 K	H 308	SR 90x9	2	3,1	TSNG 608	TSNU 608	TSNC 608	TSNA 608	TSNS 608	A 510-608	SNG 510-608
2308 K	22308 K	H 2308	SR 90x8	1								
1309 K	21309 K	H 309	SR 100x9,5	2	4,5	TSNG 609	TSNU 609	TSNC 609	TSNA 609	TSNS 609	A 511-609	SNG 511-609
2309 K	22309 K	H 2309	SR 100x8	1								
1310 K	21310 K	H 310	SR 110x10,5	2	5,0	TSNG 610	TSNU 610	TSNC 610	TSNA 610	TSNS 610	A 512-610	SNG 512-610
2310 K	22310 K	H 2310	SR 110x8	1								
1311 K	21311 K	H 311	SR 120x11	2	6,1	TSNG 611	TSNU 611	TSNC 611	TSNA 611	TSNS 611	A 513-611	SNG 513-611
2311 K	22311 K	H 2311	SR 120x8	1								
1312 K	21312 K	H 312	SR 130x12,5	2	6,5	TSNG 612	TSNU 612	TSNC 612	TSNA 612	TSNS 612	A 515-612	SNG 515-612
2312 K	22312 K	H 2312	SR 130x10	1								
1313 K	21313 K	H 313	SR 140x12,5	2	9,0	TSNG 613	TSNU 613	TSNC 613	TSNA 613	TSNS 613	A 516-613	SNG 516-613
2313 K	22313 K	H 2313	SR 140x10	1								
1315 K	21315 K	H 315	SR 160x14	2	12,4	TSNG 615	TSNU 615	TSNC 615	TSNA 615	TSNS 615	A 518-615	SNG 518-615
2315 K	22315 K	H 2315	SR 160x10	1								
1316 K	21316 K	H 316	SR 170x14,5	2	13,5	TSNG 616	TSNU 616	TSNC 616	TSNA 616	TSNS 616	A 519-616	SNG 519-616
2316 K	22316 K	H 2316	SR 170x10	1								
1317 K	21317 K	H 317	SR 180x14,5	2	17,5	TSNG 617	TSNU 617	TSNC 617	TSNA 617	TSNS 617	A 520-617	SNG 520-617
2317 K	22317 K	H 2317	SR 180x10	1								
1319 K	-	H 319	SR 200x17,5	2	20,5	TSNG 619	TSNU 619	TSNC 619	TSNA 619	TSNS 619	A 522-619	SNG 522-619
2319 K	22319 K	H 2319	SR 200x13	1								
-	-	H -	-	-	25,5	TSNG 620	TSNU 620	TSNC 620	TSNA 620	TSNS 620	A 524-620	SNG 524-620
2320 K	22320 K	H 2320	SR 215x13	1								

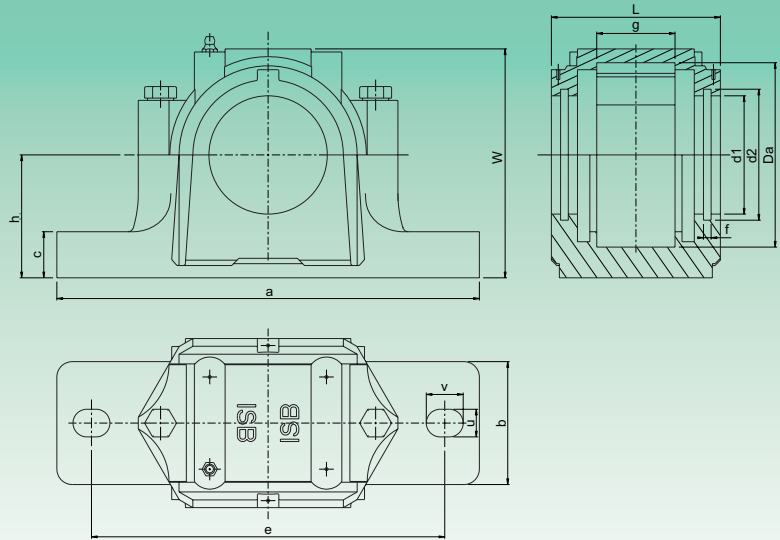
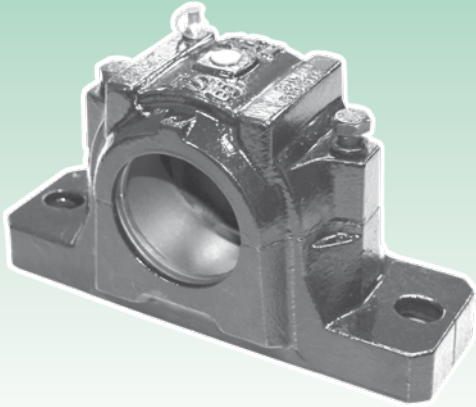

Tipo Type	Diametro albero Shaft diameter	Dimensioni - Dimensions														Bull. fiss. Bolt Size
		Da H8	a	b	c	g H12	h H12	L	w	e	v	u	d1 H12	d2 H12	f1	S
mm		mm														
SNL505	20	52	165	46	19	25	40	67	74	130	20	15	31,5	39,5	5	M8x35
SNL506	25	62	185	52	22	32	50	77	89	150	20	15	36,5	44,5	5	M8x40
SNL507-606	30	72	185	52	22	34	50	82	93	150	20	15	46,5	54,5	5	M10x50
SNL508-607	35	80	205	60	25	39	60	85	108	170	20	15	51,5	59,5	5	M10x50
SNL509	40	85	205	60	25	30	60	85	109	170	20	15	56,5	64,5	5	M10x50
SNL510-608	45	90	205	60	25	41	60	90	113	170	20	15	62	70,5	5	M10x50
SNL511-609	50	100	255	70	28	44	70	95	128	210	24	18	67	75,5	5	M12x60
SNL512-610	55	110	255	70	30	48	70	105	134	210	24	18	72	80,5	5	M12x60
SNL513-611	60	120	275	80	30	51	80	110	149	230	24	18	77	85,5	5	M12x60
SNL515-612	65	130	280	80	30	56	80	115	155	230	24	18	87	95,5	5	M12x70
SNL516-613	70	140	315	90	32	58	95	120	177	260	28	22	92,5	101	5	M16x80
SNL517	75	150	320	90	32	61	95	125	183	260	28	22	97,5	106	5	M16x80
SNL518-615	80	160	345	100	35	65	100	140	194	290	28	22	102,5	111	5	M16x80
SNL519-616	85	170	345	100	35	68	112	145	212	290	28	22	131	141	6	M16x90
SNL520-617	90	180	380	110	40	70	112	160	218	320	32	26	137,5	147,5	6	M20x90
SNL522-619	100	200	410	120	45	80	125	175	242	350	32	26	147,5	157,5	6	M20x100
SNL524-620	110	215	410	120	45	86	140	185	271	350	32	26	157,5	167,5	6	M20x110
SNL526	115	230	445	130	50	90	150	190	290	380	35	28	167,5	177,5	6	M20x110
SNL528	125	250	500	150	50	98	150	205	302	420	42	35	177,5	187,5	6	M24x130
SNL530	135	270	530	160	60	106	160	220	323	450	42	35	192,5	202,5	6	M24x130
SNL532	140	290	550	160	60	114	170	235	344	470	42	35	202,5	212,5	6	M24x130

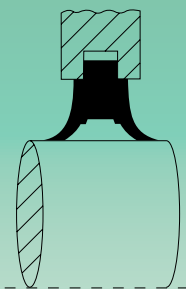

Tenuta in poliuretano "TSNG" per: SNG-SNU
"TSNG" polyurethan seal for: SNG-SNU

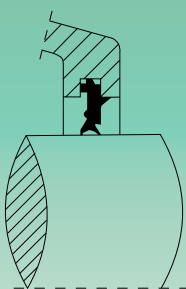

Tenuta in gomma "TSNU" per: SNG-SNU
"TSNU" rubber seal for: SNG-SNU

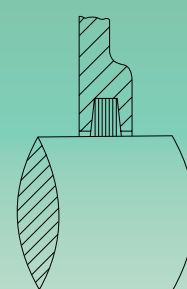

Tenuta in feltro "TSNC" per: SNG-SNU
"TSNC" felt seal for: SNG-SNU

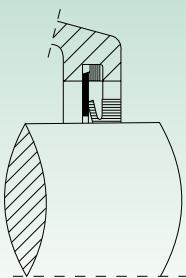

Tenuta v-ring "TSNA" per: SNG-SNU
"TSNA" v-ring seal for: SNG-SNU

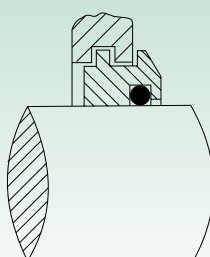

Tenuta a labirinto "TSNS" per: SNG-SNU
"TSNS" labyrinth seal for: SNG-SNU

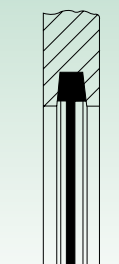

Coperchio di chiusura "A" per: SNG-SNU-SN
"A" end cover for: SNG-SNU-SN

Cuscinetto orientabile a sfere (foro conico) Self-aligning ball bearing (conical bore)	Cuscinetto orientabile a rulli (foro conico) Self-aligning roller bearing (conical bore)	Bussola (metrica) Adapter sleeve (metric)	Anello di centraggio Locating ring		Peso Weight kg	"TSNG" Tenuta in poliuretano Polyurethan seal	"TSNU" Tenuta in gomma Rubber seal	"TSNC" Tenuta in feltro Felt seal	"TSNA" Tenuta V-Ring V-Ring seal	"TSNS" Tenuta a labirinto Labyrinth seal	"A" Coperchio di chiusura End cover	Tipo Type
			Tipo Type	Q.tà Q.ty								
1205 K	-	H 205	SR 52x5	2	1,45	TSNG 505	TSNU 505	TSNC 505	TSNA 505	TSNS 505	A 505	SNL505
2205 K	22205 K	H 305	SR 52x3,5	2								
1206 K	-	H 206	SR 62x8	2	2,0	TSNG 506	TSNU 506	TSNC 506	TSNA 506	TSNS 506	A 506-605	SNL506
2206 K	22206 K	H 306	SR 62x6	2								
1207 K	-	H 207	SR 72x8,5	2	2,2	TSNG 507	TSNU 507	TSNC 507	TSNA 507	TSNS 507	A 507-606	SNL507-606
2207 K	22207 K	H 307	SR 72x5,5	2								
1208 K	-	H 208	SR 80x10,5	2	2,9	TSNG 508	TSNU 508	TSNC 508	TSNA 508	TSNS 508	A 508-607	SNL508-607
2208 K	22208 K	H 308	SR 80x8	2								
1209 K	-	H 209	SR 85x5,5	2	2,9	TSNG 509	TSNU 509	TSNC 509	TSNA 509	TSNS 509	A 509	SNL509
2209 K	22209 K	H 309	SR 85x7	1								
		H 309	SR 85x3,5	2								
1210 K	-	H 210	SR 90x10,5	2	3,2	TSNG 510	TSNU 510	TSNC 510	TSNA 510	TSNS 510	A 510-608	SNL510-608
2210 K	22210 K	H 310	SR 90x9	2								
1211 K	-	H 211	SR 100x11,5	2	4,4	TSNG 511	TSNU 511	TSNC 511	TSNA 511	TSNS 511	A 511-609	SNL511-609
2211 K	22211 K	H 311	SR 100x9,5	2								
1212 K	-	H 212	SR 110x13	2	5,1	TSNG 512	TSNU 512	TSNC 512	TSNA 512	TSNS 512	A 512-610	SNL512-610
2212 K	22212 K	H 312	SR 110x10	2								
1213 K	-	H 213	SR 120x14	2	6,5	TSNG 513	TSNU 513	TSNC 513	TSNA 513	TSNS 513	A 513-611	SNL513-611
2213 K	22213 K	H 313	SR 120x10	2								
1215 K	-	H 215	SR 130x15,5	2	7,0	TSNG 515	TSNU 515	TSNC 515	TSNA 515	TSNS 515	A 515-612	SNL515-612
2215 K	22215 K	H 315	SR 130x12,5	2								
1216 K	-	H 216	SR 140x16	2	9,5	TSNG 516	TSNU 516	TSNC 516	TSNA 516	TSNS 516	A 516-613	SNL516-613
2216 K	22216 K	H 316	SR 140x12,5	2								
1217 K	-	H 217	SR 150x16,5	2	10,0	TSNG 517	TSNU 517	TSNC 517	TSNA 517	TSNS 517	A 517	SNL517
2217 K	22217 K	H 317	SR 150x12,5	2								
1218 K	-	H 218	SR 160x17,5	2	12,5	TSNG 518	TSNU 518	TSNC 518	TSNA 518	TSNS 518	A 518-615	SNL518-615
2218 K	22218 K	H 318	SR 160x12,5	2								
2218 K	23218 K	H 2318	SR 160x12,5	1								
1219 K	-	H 219	SR 170x18	2	13,7	TSNG 519	TSNU 519	TSNC 519	TSNA 519	TSNS 519	A 519-616	SNL519-616
2219 K	22219 K	H 319	SR 170x12,5	2								
1220 K	22220 K	H 320	SR 180x12	2	17,6	TSNG 520	TSNU 520	TSNC 520	TSNA 520	TSNS 520	A 520-617	SNL520-617
2220 K	23220 K	H 2320	SR 180x9,7	1								
1222 K	22222 K	H 322	SR 200x13,5	2	22,0	TSNG 522	TSNU 522	TSNC 522	TSNA 522	TSNS 522	A 522-619	SNL522-619
2222 K	23222 K	H 2322	SR 200x10	1								
1224 K	22224 K	H 3124	SR 215x14	2	26,2	TSNG 524	TSNU 524	TSNC 524	TSNA 524	TSNS 524	A 524-620	SNL524-620
-	23224 K	H 2324	SR 215x10	1								
-	23224 K	H 2324	SR 215x5	2								
-	22226 K	H 3126	SR 230x13	2	33,0	TSNG 526	TSNU 526	TSNC 526	TSNA 526	TSNS 526	A 526	SNL526
-	23226 K	H 2326	SR 230x10	1								
-	22228 K	H 3128	SR 250x15	2	40,0	TSNG 528	TSNU 528	TSNC 528	TSNA 528	TSNS 528	A 528	SNL528
-	23228 K	H 2328	SR 250x10	1								
-	22230 K	H 3130	SR 270x16,5	2	49,0	TSNG 530	TSNU 530	TSNC 530	TSNA 530	TSNS 530	A 530	SNL530
-	23230 K	H 2330	SR 270x10	1								
-	22232 K	H 3132	SR 290x17	2	55,0	TSNG 532	TSNU 532	TSNC 532	TSNA 532	TSNS 532	A 532	SNL532
-	23232 K	H 2332	SR 290x10	1								

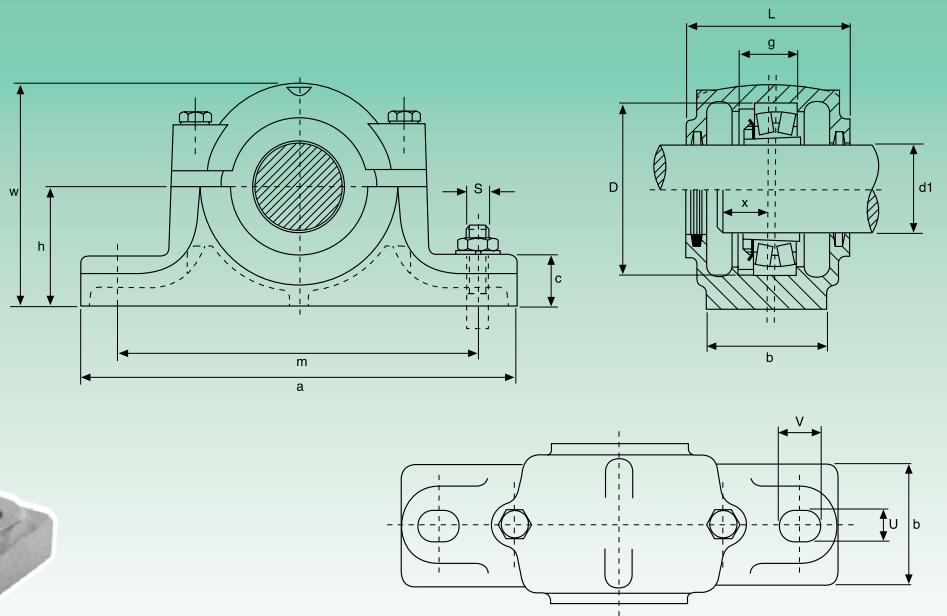
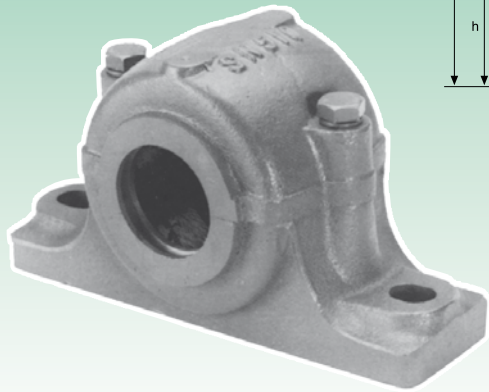

Tipo Type	Diametro albero Shaft diameter		Dimensioni - Dimensions										Bull. fiss. Bolt Size	
	d1		D H8	a	b	c	g H12	h h12	L ± 5	w	m	U	V	S
	mm	inch	mm/inch											
SN 506	25	1	62	185	52	22	30	50	77	90	150	15	20	M12
SN 507	30	1 1/8	72	185	52	22	33	50	82	95	150	15	20	M12
SN 508	35	1 1/4	80	205	60	25	33	60	85	110	170	15	20	M12
SN 509	40	1 1/2	85	205	60	25	31	60	85	112	170	15	20	M12
SN 510	45	1 3/4	90	205	60	25	33	60	90	115	170	15	20	M12
SN 511	50	2	100	255	70	28	33	70	95	130	210	18	23	M16
SN 512	55	2 1/8	110	255	70	30	38	70	105	135	210	18	23	M16
SN 513	60	2 1/4	120	275	80	30	43	80	110	150	230	18	23	M16
SN 515	65	2 1/2	130	280	80	30	41	80	115	155	230	18	23	M16
SN 516	70	2 3/4	140	315	90	32	43	95	120	175	260	22	27	M20
SN 517	75	3	150	320	90	32	46	95	125	185	260	22	27	M20
SN 518	80	3 1/4	160	345	100	35	62,4	100	145	195	290	22	27	M20
SN 519	85	-	170	345	100	35	53	112	140	210	290	22	27	M20
SN 520	90	3 1/2	180	380	110	40	70,3	112	160	218	320	26	32	M24
SN 522	100	4	200	410	120	45	80	125	175	240	350	26	32	M24
SN 524	110	4 1/4	215	410	120	45	86	140	185	270	350	26	32	M24
SN 526	115	4 1/2	230	445	130	50	90	150	190	290	380	28	36	M24
SN 528	125	5	250	500	150	50	98	150	205	305	420	33	42	M30
SN 530	135	5 1/4	270	530	160	60	106	160	220	325	450	33	42	M30
SN 532	140	5 1/2	290	550	160	60	114	170	235	345	470	33	42	M30

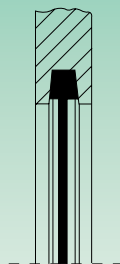
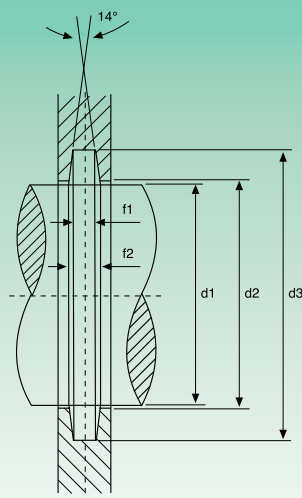

Coperchio di chiusura "A" per: SNG-SNU-SN
"A" end cover for: SNG-SNU-SN

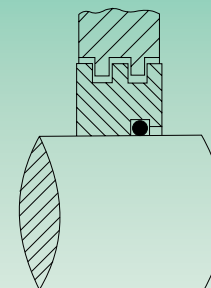

Tenuta a labirinto "TS" per: SN-SD
"TS" labyrinth seal for: SN-SD

Se non diversamente specificato viene fornito il supporto aperto di tipo "B"
Unless specified "B" type open housing supplied

X	Dimensioni - Dimensions				Peso Weight kg	Cuscinetto orientabile a sfere (foro conico) Self-aligning ball bearing (conical bore)	Cuscinetto orientabile a rulli (foro conico) Self-aligning roller bearing (conical bore)	Bussola Adapter sleeve		Anello di centraggio Locating ring		"A" Coperchio di chiusura End cover	"TS" Tenuta a labirinto Labyrinth seal	Tipo Type
	d2 H12	d3 H12	f1 H13	f2				mm	inch	Tipo Type	Q.tà Q.ty			
22	26,5	38	4	5,4	1,6	1206 K	-	H 206	HE 206	SR 62x7	2	A 506	TS 506	SN 506
						2206 K	22206 K	H 306	HE 306	SR 62x10	1			
24	31,5	43	4	5,4	2,1	1207 K	-	H 207	HE 207	SR 72x8	2	A 507	TS 507	SN 507
						2207 K	22207 K	H 307	HE 307	SR 72x10	1			
26	36,5	48	4	5,4	2,7	1208 K	-	H 208	HE 208	SR 80x7,5	2	A 508	TS 508	SN 508
						2208 K	22208 K	H 308	HE 308	SR 80x10	1			
28	41,5	53	4	5,4	2,8	1209 K	-	H 209	HE 209	SR 85x6	2	A 509	TS 509	SN 509
						2209 K	22209 K	H 309	HE 309	SR 85x8	1			
28	46,5	58	4	5,4	3,0	1210 K	-	H 210	HE 210	SR 90x6,5	2	A 510	TS 510	SN 510
						2210 K	22210 K	H 310	HE 310	SR 90x10	1			
30	51,5	67	5	6,9	4,0	1211 K	-	H 211	HE 211	SR 100x6	2	A 511	TS 511	SN 511
						2211 K	22211 K	H 311	HE 311	SR 100x8	1			
32	56,5	72	5	6,9	4,5	1212 K	-	H 212	HE 212	SR 110x8	2	A 512	TS 512	SN 512
						2212 K	22212 K	H 312	HE 312	SR 110x10	1			
36	62	77	5	6,8	5,5	1213 K	-	H 213	HE 213	SR 120x10	2	A 513	TS 513	SN 513
						2213 K	22213 K	H 313	HE 313	SR 120x12	1			
38	67	82	5	6,8	6,0	1215 K	-	H 215	HE 215	SR 130x8	2	A 515	TS 515	SN 515
						2215 K	22215 K	H 315	HE 315	SR 130x10	1			
40	72	89	6	8,1	8,2	1216 K	-	H 216	HE 216	SR 140x8,5	2	A 516	TS 516	SN 516
						2216 K	22216 K	H 316	HE 316	SR 140x10	1			
42	77	94	6	8,1	9,0	1217 K	-	H 217	HE 217	SR 150x9	2	A 517	TS 517	SN 517
						2217 K	22217 K	H 317	HE 317	SR 150x10	1			
50	82	99	6	8,1	11,6	1218 K	22218 K	H 218	HE 218	SR 160x16,2	2	A 518	TS 518	SN 518
						2218 K	23218 K	H 318	HE 318	SR 160x11,2	2			
						1219 K	-	H 219	HE 219	SR 160x10	1			
52	87	104	6	8,1	11,8	2219 K	22219 K	H 319	HE 319	SR 170x10,5	2	A 519	TS 519	SN 519
						2219 K	22219 K	H 319	HE 319	SR 170x10	1			
54	92	111	7	9,3	15,5	2220 K	22220 K	H 320	HE 320	SR 180x12,1	2	A 520	TS 520	SN 520
						-	23220 K	H 2320	HE 2320	SR 180x10	1			
60	102	125	8	10,8	19	2222 K	22222 K	H 322	HE 322	SR 200x13,5	2	A 522	TS 522	SN 522
						-	23222 K	H 2322	HE 2322	SR 200x10	1			
64	113	135	8	10,7	23	-	22224 K	H 3124	HE 3124	SR 215x14	2	A 524	TS 524	SN 524
						-	23224 K	H 2324	HE 2324	SR 215x10	1			
64	118	140	8	10,7	28	-	22226 K	H 3126	HE 3126	SR 230x13	2	A 526	TS 526	SN 526
						-	23226 K	H 2326	HE 2326	SR 230x10	1			
70	128	154	9	12,2	37	-	22228 K	H 3128	HE 3128	SR 250x15	2	A 528	TS 528	SN 528
						-	23228 K	H 2328	HE 2328	SR 250x10	1			
76	138	164	9	12,2	44	-	22230 K	H 3130	HE 3130	SR 270x16,5	2	A 530	TS 530	SN 530
						-	23230 K	H 2330	HE 2330	SR 270x10	1			
80	143	173	10	13,7	50	-	22232 K	H 3132	HE 3132	SR 290x17	2	A 532	TS 532	SN 532
						-	23232 K	H 2332	HE 2332	SR 290x10	1			

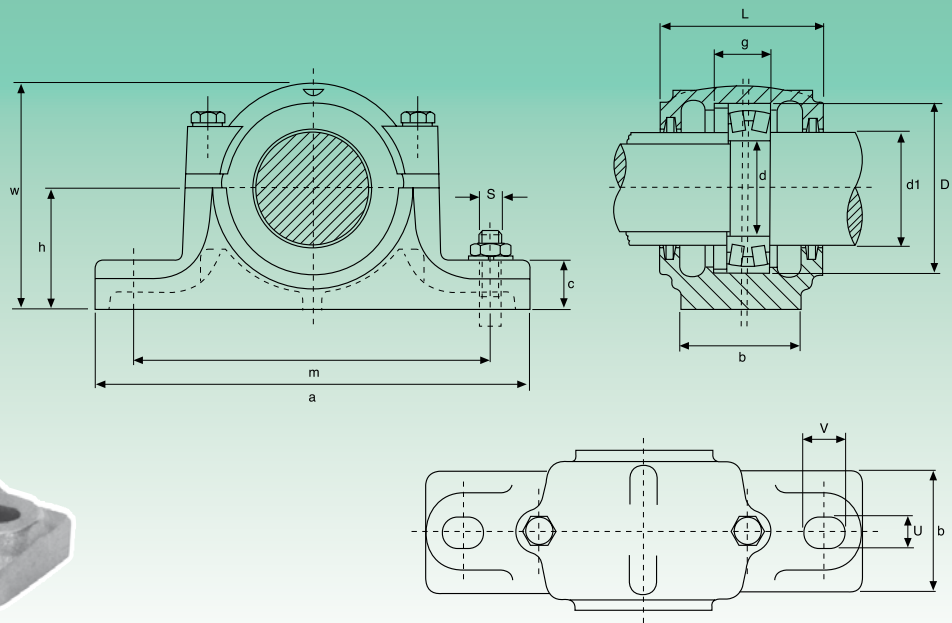
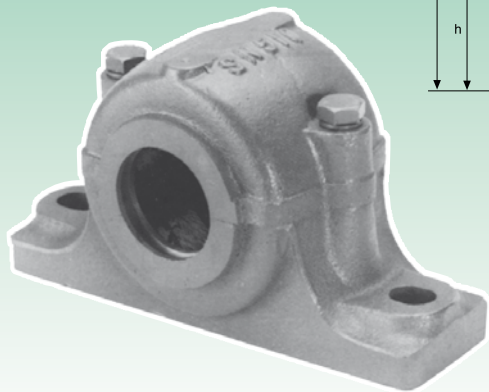

Tipo Type	Diametro albero Shaft diameter			Dimensioni - Dimensions											
	d	d0	d1	D H8	a	b	c	g H12	h h12	L ± 5	w	m	n	U	V
	mm			mm											
SN 207	35	30	45	72	185	52	22	33	50	82	95	150	-	15	20
SN 208	40	35	50	80	205	60	25	33	60	85	110	170	-	15	20
SN 209	45	40	55	85	205	60	25	31	60	85	112	170	30	15	20
SN 210	50	45	60	90	205	60	25	33	60	90	115	170	30	15	20
SN 211	55	50	65	100	255	70	28	33	70	95	130	210	35	18	23
SN 212	60	55	70	110	255	70	30	38	70	105	135	210	35	18	23
SN 213	65	60	75	120	275	80	30	43	80	110	150	230	40	18	23
SN 215	75	65	85	130	280	80	30	41	80	115	155	230	40	18	23
SN 216	80	70	90	140	315	90	32	43	95	120	175	260	50	22	27
SN 217	85	75	95	150	320	90	32	46	95	125	185	260	50	22	27
SN 218	90	80	100	160	345	100	35	62,4	100	145	195	290	50	22	27
SN 220	100	90	115	180	380	110	40	70,3	112	160	218	320	60	26	32
SN 222	110	100	125	200	410	120	45	80	125	175	240	350	70	26	32
SN 224	120	110	135	215	410	120	45	86	140	185	270	350	70	26	32
SN 226	130	115	145	230	445	130	50	90	150	190	290	380	70	28	36
SN 228	140	125	155	250	500	150	50	98	150	205	305	420	80	33	42
SN 230	150	135	165	270	530	160	60	106	160	220	325	450	90	33	42
SN 232	160	140	175	290	550	160	60	114	170	235	345	470	90	33	42

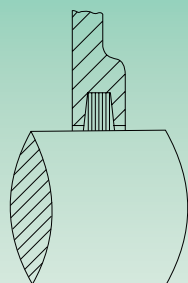
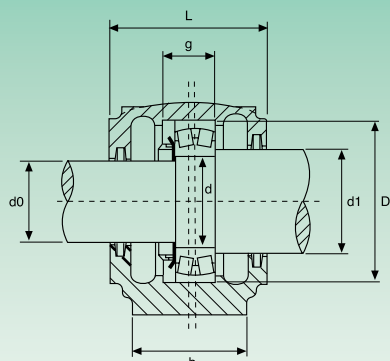

Tenuta in feltro "TSNC" per: SNG-SNU
"TSNC" felt seal for: SNG-SNU

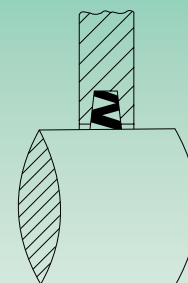

Tenuta in NBR "ZF" per: SN
"ZF" NBR seal for: SN

S		Cuscinetto orientabile a sfere Self-aligning ball bearing	Cuscinetto orientabile a rulli Self-aligning roller bearing	Ghiera di bloccaggio Lock nut KM	Rosetta Washer MB	"TSNC" Tenuta in feltro Felt seal		"ZF" Tenuta in NBR NBR seal		Anello di centraggio Locating ring		Tipo Type
2 Bull. Fiss. 2 Bolt size	4 Bull. Fiss. 4 Bolt size					d0	d1	d0	d1	Tipo Type	Q.tà Q.ty	
M 12	-	1207 2207	22207	KM 07	MB 07	TSNC 207	TSNC 210	ZF 207	ZF 210	SR 72x8 SR 72x10	2 1	SN 207
M 12	-	1208 2208	22208	KM 08	MB 08	TSNC 208	TSNC 211	ZF 208	ZF 211	SR 80x7,5 SR 80x10	2 1	SN 208
M 12	M 10	1209 2209	22209	KM 09	MB 09	TSNC 209	TSNC 212	ZF 209	ZF 212	SR 85x6 SR 85x8	2 1	SN 209
M 12	M 10	1210 2210	22210	KM 10	MB 10	TSNC 210	TSNC 213	ZF 210	ZF 213	SR 90x6,5 SR 90x10	2 1	SN 210
M 16	M 12	1211 2211	22211	KM 11	MB 11	TSNC 211	TSNC 215	ZF 211	ZF 215	SR 100x6 SR 100x8	2 1	SN 211
M 16	M 12	1212 2212	22212	KM 12	MB 12	TSNC 212	TSNC 216	ZF 212	ZF 216	SR 110x8 SR 110x10	2 1	SN 212
M 16	M 12	1213 2213	22213	KM 13	MB 13	TSNC 213	TSNC 217	ZF 213	ZF 217	SR 120x10 SR 120x12	2 1	SN 213
M 16	M 12	1215 2215	22215	KM 15	MB 15	TSNC 215	TSNC 219	ZF 215	ZF 219	SR 130x8 SR 130x10	2 1	SN 215
M 20	M 16	1216 2216	22216	KM 16	MB 16	TSNC 216	TSNC 220	ZF 216	ZF 220	SR 140x8,5 SR 140x10	2 1	SN 216
M 20	M 16	1217 2217	22217	KM 17	MB 17	TSNC 217	TSNC 221	ZF 217	ZF 221	SR 150x9 SR 150x10	2 1	SN 217
M 20	M 16	1218 2218	22218 23218	KM 18	MB 18	TSNC 218	TSNC 222	ZF 218	ZF 222	SR 160x16,2 SR 160x11,2 SR 160x10	2 2 1	SN 218
M 24	M 16	2220	22220 23220	KM 20	MB 20	TSNC 220	TSNC 226	ZF 220	ZF 226	SR 180x12,1 SR 180x10	2 1	SN 220
M 24	M 16	2222	22222 23222	KM 22	MB 22	TSNC 222	TSNC 228	ZF 222	ZF 228	SR 200x13,5 SR 200x10	2 1	SN 222
M 24	M 16	-	22224 23224	KM 24	MB 24	TSNC 224	TSNC 230	ZF 224	ZF 230	SR 215x14 SR 215x10	2 1	SN 224
M 24	M 20	-	22226 23226	KM 26	MB 26	TSNC 226	TSNC 233	ZF 226	ZF 233	SR 230x13 SR 230x10	2 1	SN 226
M 30	M 24	-	22228 23228	KM 28	MB 28	TSNC 228	TSNC 235	ZF 228	ZF 235	SR 250x15 SR 250x10	2 1	SN 228
M 30	M 24	-	22230 23230	KM 30	MB 30	TSNC 230	TSNC 237	ZF 230	ZF 237	SR 270x16,5 SR 270x10	2 1	SN 230
M 30	M 24	-	22232 23232	KM 32	MB 32	TSNC 232	TSNC 239	ZF 232	ZF 239	SR 290x17 SR 290x10	2 1	SN 232

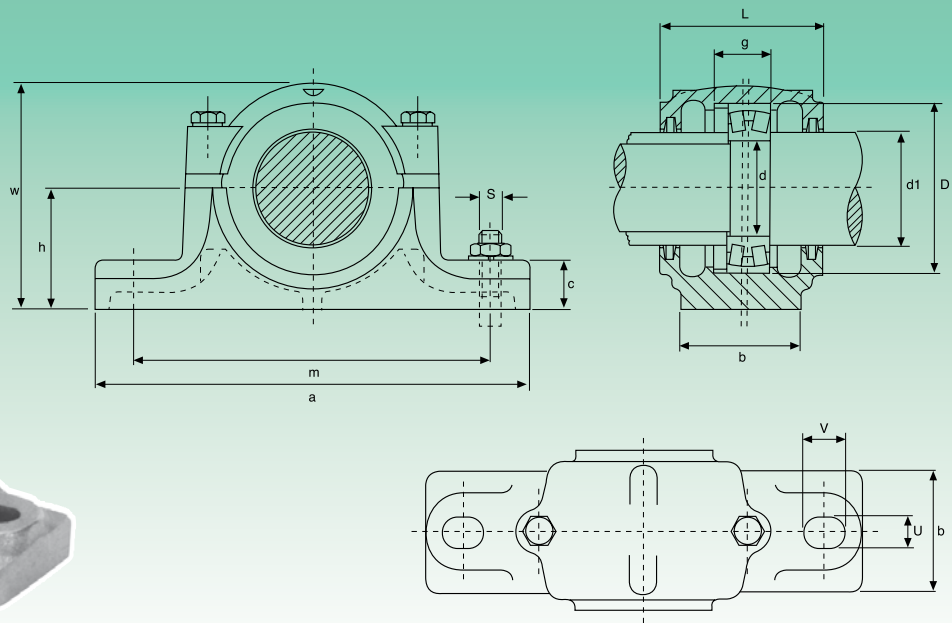
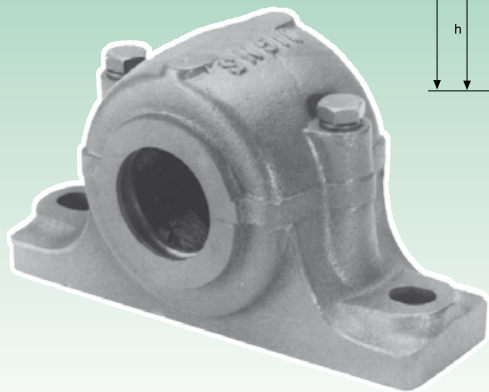

Tipo Type	Diametro albero Shaft diameter			Dimensioni - Dimensions											
	d	d0	d1	D H8	a	b	c	g H12	h h12	L ± 5	w	m	n	U	V
	mm			mm											
SN 307	35	30	45	80	205	60	25	41	60	90	110	170	-	15	20
SN 308	40	35	50	90	205	60	25	43	60	95	115	170	-	15	20
SN 309	45	40	55	100	255	70	28	46	70	105	130	210	-	18	23
SN 310	50	45	60	110	255	70	30	50	70	115	135	210	-	18	23
SN 311	55	50	65	120	275	80	30	53	80	120	150	230	40	18	23
SN 312	60	55	70	130	280	80	30	56	80	125	155	230	40	18	23
SN 313	65	60	75	140	315	90	32	58	95	130	175	260	50	22	27
SN 315	75	65	85	160	345	100	35	65	100	140	195	290	50	22	27
SN 316	80	70	90	170	345	100	35	68	112	145	212	290	50	22	27
SN 317	85	75	95	180	380	110	40	70	112	155	218	320	60	26	32
SN 318	90	80	100	190	400	110	33	74	112	160	230	320	60	26	35
SN 319	95	85	110	200	420	120	36	77	125	170	245	350	70	26	35
SN 320	100	90	115	215	420	120	38	83	140	175	280	350	70	26	35
SN 322	110	100	125	240	460	130	40	90	150	190	300	390	70	28	38
SN 324	120	110	135	260	540	160	50	96	160	205	325	450	90	33	42
SN 326	130	115	150	280	560	160	50	103	170	215	350	470	90	33	42
SN 328	140	125	160	300	630	170	55	112	180	235	375	520	90	35	45
SN 330	150	135	170	320	680	180	55	118	190	245	395	560	90	35	45
SN 332	160	140	180	340	710	190	60	124	200	255	415	580	100	42	52

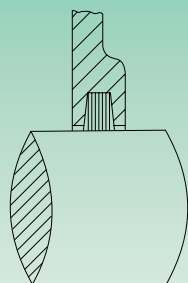
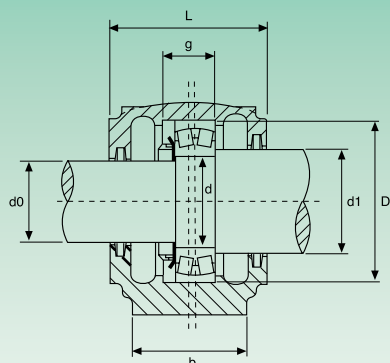

Tenuta in feltro "TSNC" per: SNG-SNU
"TSNC" felt seal for: SNG-SNU

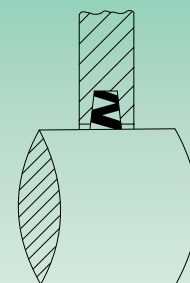

Tenuta in NBR "ZF" per: SN
"ZF" NBR seal for: SN

S		Cuscinetto orientabile a sfere Self-aligning ball bearing	Cuscinetto orientabile a rulli Self-aligning roller bearing	Ghiera di bloccaggio Lock nut	Rosetta Washer	"TSNC" Tenuta in feltro Felt seal		"ZF" Tenuta in NBR NBR seal		Anello di centraggio Locating ring		Tipo Type
2 Bull. Fiss. 2 Bolt size	4 Bull. Fiss. 4 Bolt size					KM	MB	d0	d1	d0	d1	
M 12	-	1307 2307	-	KM 07	MB 07	TSNC 307	TSNC 310	ZF 307	ZF 310	SR 80x10	2	SN 307
										SR 80x10	1	
M 12	-	1308 2308	21308 22308	KM 08	MB 08	TSNC 308	TSNC 311	ZF 308	ZF 311	SR 90x10	2	SN 308
										SR 90x10	1	
M 16	-	1309 2309	21309 22309	KM 09	MB 09	TSNC 309	TSNC 312	ZF 309	ZF 312	SR 100x10,5	2	SN 309
										SR 100x10	1	
M 16	-	1310 2310	21310 22310	KM 10	MB 10	TSNC 310	TSNC 313	ZF 310	ZF 313	SR 110x11,5	2	SN 310
										SR 110x10	1	
M 16	M 12	1311 2311	21311 22311	KM 11	MB 11	TSNC 311	TSNC 315	ZF 311	ZF 315	SR 120x12	2	SN 311
										SR 120x10	1	
M 16	M 12	1312 2312	21312 22312	KM 12	MB 12	TSNC 312	TSNC 316	ZF 312	ZF 316	SR 130x12,5	2	SN 312
										SR 130x10	1	
M 20	M 16	1313 2313	21313 22313	KM 13	MB 13	TSNC 313	TSNC 317	ZF 313	ZF 317	SR 140x12,5	2	SN 313
										SR 140x10	1	
M 20	M 16	1315 2315	21315 22315	KM 15	MB 15	TSNC 315	TSNC 319	ZF 315	ZF 319	SR 160x14	2	SN 315
										SR 160x10	1	
M 20	M 16	1316 2316	21316 22316	KM 16	MB 16	TSNC 316	TSNC 320	ZF 316	ZF 320	SR 170x14,5	2	SN 316
										SR 170x10	1	
M 24	M 16	1317 2317	21317 22317	KM 17	MB 17	TSNC 317	TSNC 321	ZF 317	ZF 321	SR 180x14,5	2	SN 317
										SR 180x10	1	
M 24	M 16	1318 2318	21318 22318	KM 18	MB 18	TSNC 318	TSNC 322	ZF 318	ZF 322	SR 190x15,5	2	SN 318
										SR 190x10	1	
M 24	M 16	1319 2319	21319 22319	KM 19	MB 19	TSNC 319	TSNC 324	ZF 319	ZF 324	SR 200x16	2	SN 319
										SR 200x10	1	
M 24	M 16	1320 2320	21320 22320	KM 20	MB 20	TSNC 320	TSNC 326	ZF 320	ZF 326	SR 215x18	2	SN 320
										SR 215x10	1	
M 24	M 16	1322 2322	21322	KM 22	MB 22	TSNC 322	TSNC 328	ZF 322	ZF 328	SR 240x20	2	SN 322
										SR 240x10	1	
M 30	M 20	-	22324	KM 24	MB 24	TSNC 324	TSNC 330	ZF 324	ZF 330	SR 260x10	1	SN 324
M 30	M 20	-	22326	KM 26	MB 26	TSNC 326	TSNC 334	ZF 326	ZF 334	SR 280x10	1	SN 326
M 30	M 20	-	22328	KM 28	MB 28	TSNC 328	TSNC 336	ZF 328	ZF 336	SR 300x10	1	SN 328
M 30	M 20	-	22330	KM 30	MB 30	TSNC 330	TSNC 338	ZF 330	ZF 338	SR 320x10	1	SN 330
M 36	M 24	-	22332	KM 32	MB 32	TSNC 332	TSNC 340	ZF 332	ZF 340	SR 340x10	1	SN 332

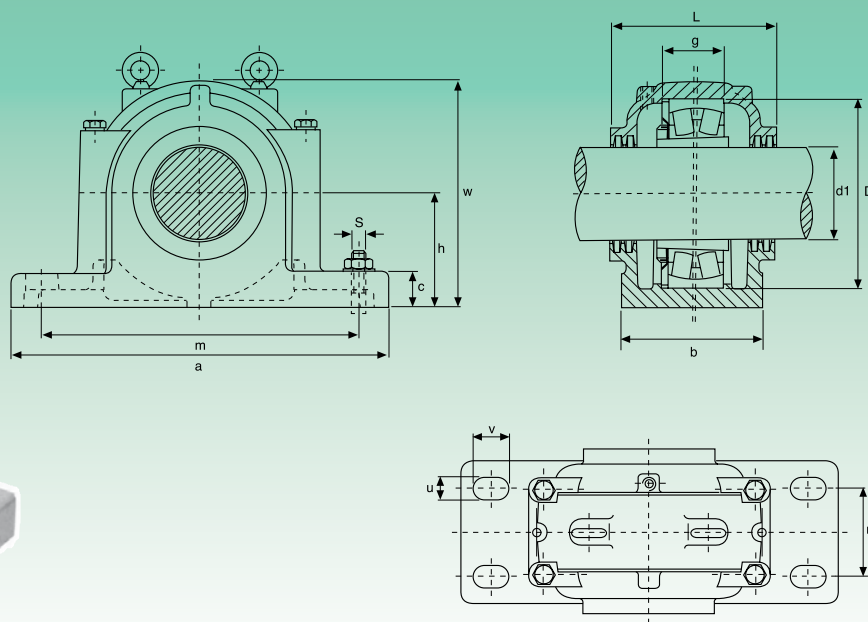
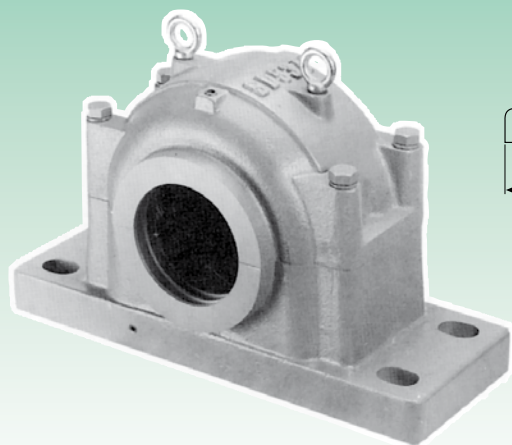

Tipo Type	Diametro albero Shaft diameter	Dimensioni - Dimensions											
	d1	D H8	a	b	c	g H12	h h12	L ± 5	w	m	n	U	V
	mm	mm											
SD 3034	150	260	540	200	50	77	160	230	320	450	110	36	52
SD 3036	160	280	560	220	50	84	170	250	340	470	120	36	52
SD 3038	170	290	560	220	50	85	170	250	345	470	120	36	52
SD 3040	180	310	620	230	60	92	180	270	360	510	140	36	52
SD 3044	200	340	700	260	65	100	200	290	400	570	160	36	55
SD 3048	220	360	740	270	65	102	210	300	420	610	170	36	55
SD 3052	240	400	820	300	70	114	240	330	475	680	190	43	62
SD 3056	260	420	860	320	85	116	250	350	500	710	200	43	62
SD 3060	280	460	920	330	85	128	280	360	550	770	210	43	62
SD 3064	300	480	940	340	85	131	280	370	560	790	210	43	62
SD 3068	320	520	1020	370	100	143	310	400	615	860	230	50	70
SD 3072	340	540	1060	390	100	144	325	410	640	890	250	50	70
SD 3076	360	560	1080	390	100	145	340	410	665	900	260	50	70

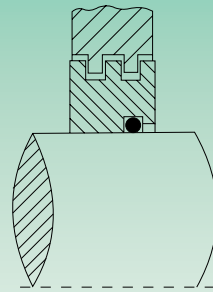
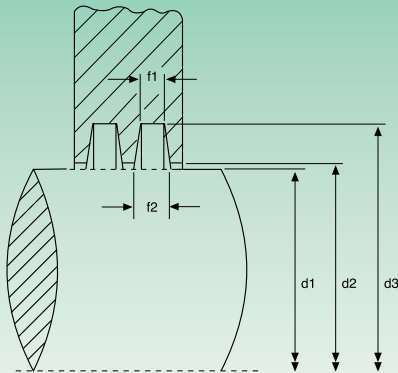

Tenuta a labirinto "TS" per: SN-SD
"TS" labyrinth seal for: SN-SD

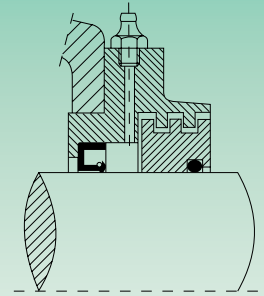

Chiusura di taconite "TAC" per: SN-SD
"TAC" taconite cover for: SN-SD

Bull. fiss. Bolt Size	Dimensioni - Dimensions				Peso Weight	Cuscinetto orientabile a rulli (foro conico) Self-aligning roller bearing (conical bore)	Bussola (metrica) Adapter sleeve (metric)	Anello di centraggio Locating ring		"TS" Tenuta a labirinto Labyrinth seal	"ETS" Coperchio Cover
	d2 H12	d3 H12	f1 H13	f2				Tipo Type	Q.tà Q.ty		
S	mm				kg						
M 30	153	183	10	13,8	62	23034 K	H 3034	SR 260x10	1	TS 3034	ETS 3034
M 30	163	193	10	13,8	78	23036 K	H 3036	SR 280x10	1	TS 3036	ETS 3036
M 30	173	203	10	13,8	82	23038 K	H 3038	SR 290x10	1	TS 3038	ETS 3038
M 30	183	213	10	13,8	92	23040 K	H 3040	SR 310x10	1	TS 3040	ETS 3040
M 30	203	240	11	15,7	125	23044 K	H 3044	SR 340x10	1	TS 3044	ETS 3044
M 30	223	260	11	15,7	140	23048 K	H 3048	SR 360x10	1	TS 3048	ETS 3048
M 36	243	286	12	17,4	200	23052 K	H 3052	SR 400x10	1	TS 3052	ETS 3052
M 36	263	306	12	17,4	230	23056 K	H 3056	SR 420x10	1	TS 3056	ETS 3056
M 36	283	332	13	19,1	290	23060 K	H 3060	SR 460x10	1	TS 3060	ETS 3060
M 36	303	352	13	19,1	300	23064 K	H 3064	SR 480x10	1	TS 3064	ETS 3064
M 42	323	372	13	19,1	400	23068 K	H 3068	SR 520x10	1	TS 3068	ETS 3068
M 42	343	392	13	19,1	450	23072 K	H 3072	SR 540x10	1	TS 3072	ETS 3072
M 42	363	412	13	19,1	470	23076 K	H 3076	SR 560x10	1	TS 3076	ETS 3076

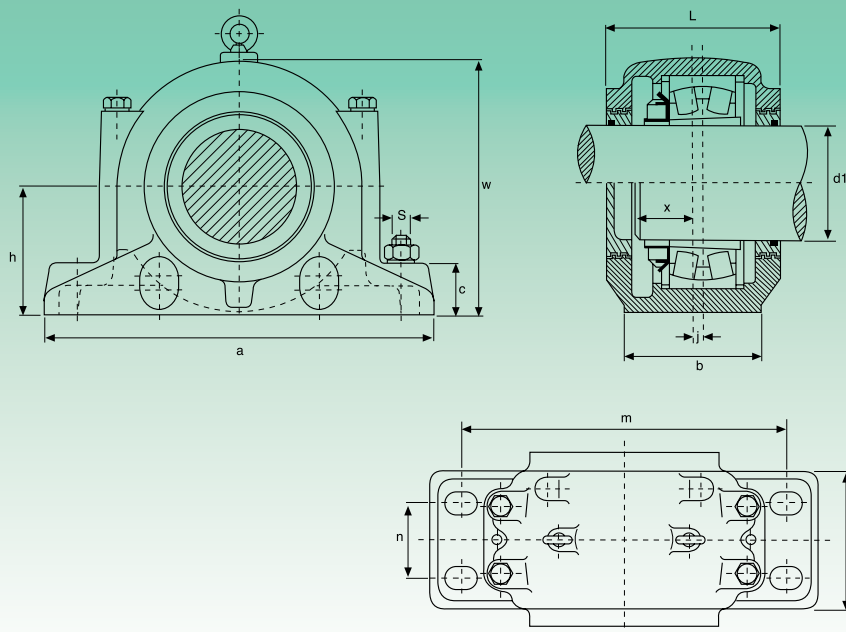

Tipo Type	Diametro albero Shaft diameter		Dimensioni - Dimensions												
	d1		D H8	a	b	c	g H12	h h12	L ± 5	L2	w	m	n	U	U
	mm	inch													
SD 3134	150	6	280	510	180	70	108	170	230	308	335	430	100	30	36
SD 3136	160	6½	300	530	190	75	116	180	240	318	355	450	110	30	36
SD 3138	170	6¾	320	560	210	80	124	190	260	336	375	480	120	30	38
SD 3140	180	7	340	610	230	85	132	210	280	356	410	510	130	35	40
SD 3144	200	-	370	640	240	90	140	220	290	368	435	540	140	35	40
SD 3148	220	-	400	700	260	95	148	240	310	388	475	600	150	35	40
SD 3152	240	-	440	770	280	100	164	260	320	400	515	650	160	40	48
SD 3156	260	-	460	790	280	105	166	280	320	400	550	670	160	42	50
SD 3160	280	-	500	830	310	110	180	300	350	426	590	710	190	42	60
SD 3164	300	-	540	880	330	115	196	320	370	448	630	750	200	42	60
SD 3168	320	-	580	965	380	120	210	340	390	488	670	840	240	49	59
SD 3172	340	-	600	1040	390	130	212	360	390	498	720	890	255	49	59
SD 3176	360	-	620	1120	400	135	214	380	405	520	750	980	255	60	72
SD 3180	380	-	650	1245	420	140	220	400	425	543	790	1050	270	65	78

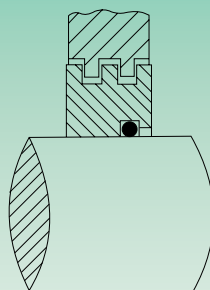
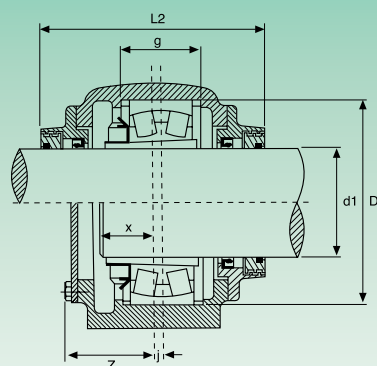

Tenuta a labirinto "TS" per: SN-SD
"TS" labyrinth seal for: SN-SD

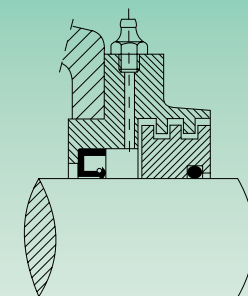

Chiusura di taconite "TAC" per: SN-SD
"TAC" taconite cover for: SN-SD

Dimensioni - Dimensions			Bull. fiss. Bolt Size	Peso Weight	Cuscinetto orientabile a rulli (foro conico) Self-aligning roller bearing (conical bore)	Bussola Adapter sleeve		Anello di centraggio Locating ring		"TS" Tenuta a labirinto Labyrinth seal	"ETS" Coperchio Cover	"TAC" Chiusura di taconite Taconite cover
J	X	Z				S	mm	inch	Tipo Type			
mm				kg								
14	65	120	M 24	70	23134 K	H 3134	HE 3134	SR 280x10	2	TS 3134	ETS 3134	TAC 3134
15	68	130	M 24	72	23136 K	H 3136	HE 3136	SR 300x10	2	TS 3136	ETS 3136	TAC 3136
10	80	140	M 24	88	23138 K	H 3138	HE 3138	SR 320x10	2	TS 3138	ETS 3138	TAC 3138
10	82	150	M 30	122	23140 K	H 3140	HE 3140	SR 340x10	2	TS 3140	ETS 3140	TAC 3140
12	90	155	M 30	136	23144 K	H 3144	-	SR 370x10	2	TS 3144	ETS 3144	TAC 3144
12	100	160	M 30	190	23148 K	H 3148	-	SR 400x10	2	TS 3148	ETS 3148	TAC 3148
13	105	170	M 36	238	23152 K	H 3152	-	SR 440x10	2	TS 3152	ETS 3152	TAC 3152
16	105	170	M 36	252	23156 K	H 3156	-	SR 460x10	2	TS 3156	ETS 3156	TAC 3156
22	110	190	M 36	290	23160 K	H 3160	-	SR 500x10	2	TS 3160	ETS 3160	TAC 3160
23	120	200	M 36	340	23164 K	H 3164	-	SR 540x10	2	TS 3164	ETS 3164	TAC 3164
25	135	220	M 45	430	23168 K	H 3168	-	SR 580x10	2	TS 3168	ETS 3168	TAC 3168
22	145	225	M 50	560	23172 K	H 3172	-	SR 600x10	2	TS 3172	ETS 3172	TAC 3172
22	145	240	M 55	770	23176 K	H 3176	-	SR 620x10	2	TS 3176	ETS 3176	TAC 3176
22	150	260	M 60	870	23180 K	H 3180	-	SR 650x10	2	TS 3180	ETS 3180	TAC 3180

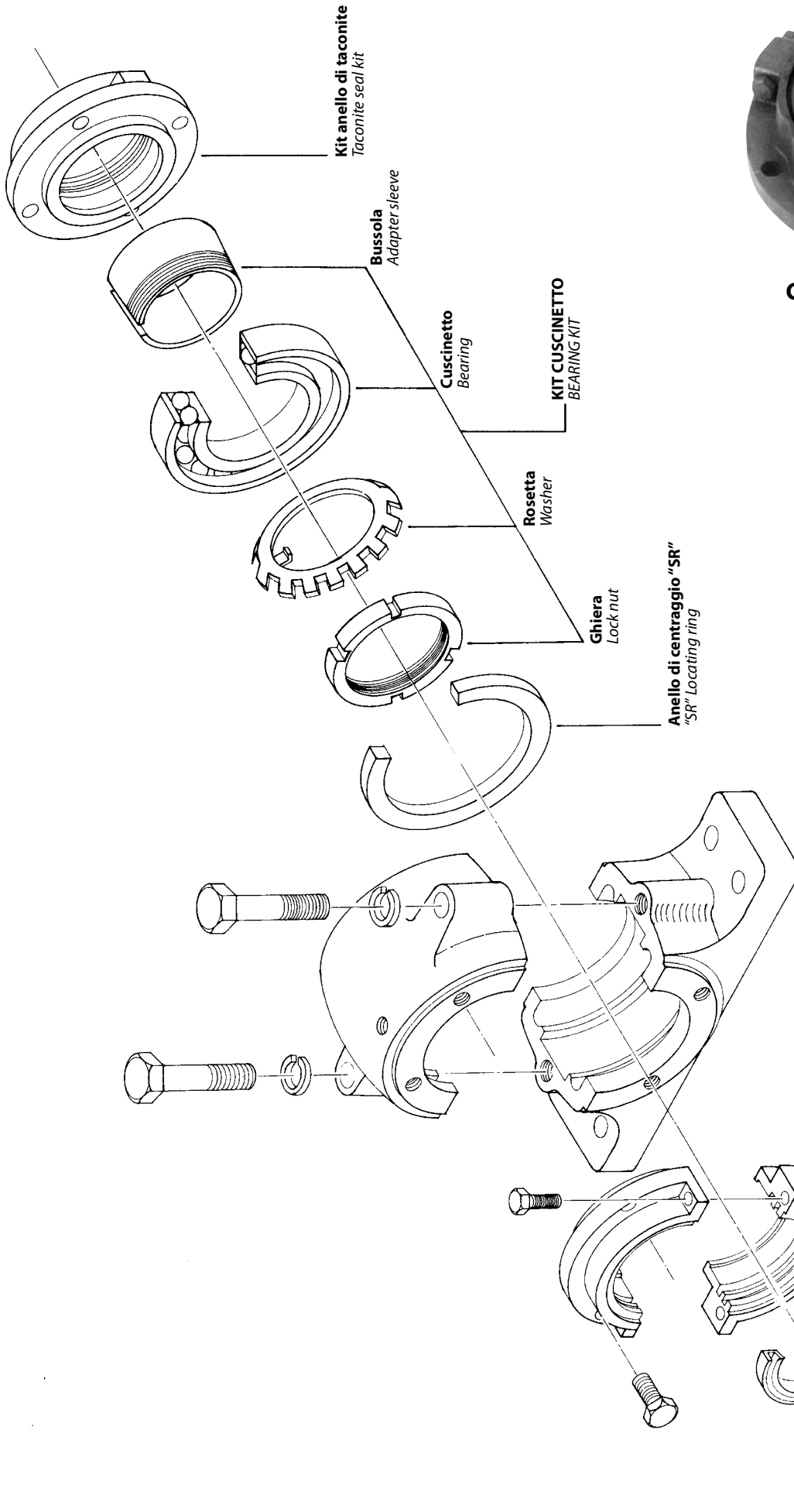

CHIUSURA DI TACONITE
TACONITE COVER

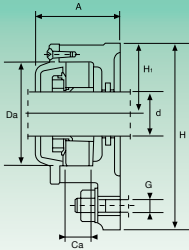
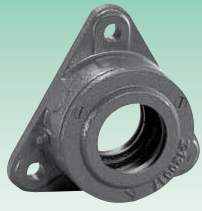

DB coperchio aperto - Open cover

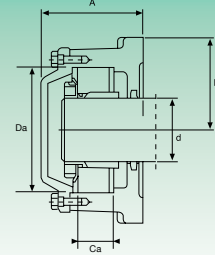
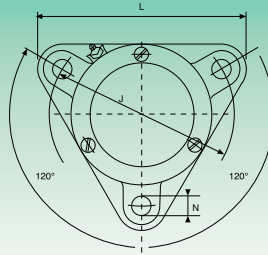

DA coperchio chiuso - Closed cover

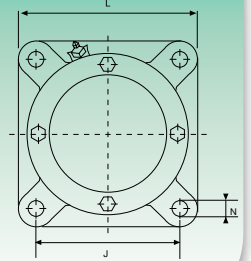

Tipo Type	Dimensioni - Dimensions										Peso Weight kg	Cuscinetti appropriati - Suitable bearings			Forma flangia Flange
	d	A	L	H	H ₁	N	J	Da	Ca	G		Cuscinetti orientabile a sfere Self-aligning ball bearings	Anello d'arresto Locating ring		
	mm											Cuscinetti orientabile a rulli Cylindrical roller bearings			
722505 DA	20	51,5	110	100	38	11,5	96	52	20	10	1,10	1205 K 22205 K	2205 K SR52x5	SR52x2	▲
722505 DB	20	56,5	110	100	38	11,5	96	52	20	10	1,10	1205 K 22205 K	2205 K SR52x5	SR52x2	▲
722506 DA	25	57	130	117	44	11,5	116	62	22	10	1,50	1206 K 22206 K	2206 K SR62x6	SR62x2	▲
722506 DB	25	59,5	130	117	44	11,5	116	62	22	10	1,50	1206 K 22206 K	2206 K SR62x6	SR62x2	▲
722507 DA	30	59,5	145	129,5	48,5	14	130	72	25	12	1,80	1207 K 22207 K	2207 K SR72x8	SR72x2	▲
722507 DB	30	63,5	145	129,5	48,5	14	130	72	25	12	1,80	1207 K 22207 K	2207 K SR72x8	SR72x2	▲
722508 DA	35	64	160	143	54	14	140	80	25	12	2,30	1208 K 22208 K	2208 K SR80x7	SR80x2	▲
722508 DB	35	65,5	160	143	54	14	140	80	25	12	2,30	1208 K 22208 K	2208 K SR80x7	SR80x2	▲
722509 DA	40	64,5	180	160	60	14	160	85	25	12	3,0	1209 K 22209 K	2209 K SR85x6	SR85x2	▲
722509 DB	40	69,5	180	160	60	14	160	85	25	12	3,0	1209 K 22209 K	2209 K SR85x6	SR85x2	▲
722510 DA	45	68,5	180	160	60	14	160	90	25	12	3,0	1210 K 22210 K	2210 K SR90x5	SR90x2	▲
722510 DB	45	73	180	160	60	14	160	90	25	12	3,0	1210 K 22210 K	2210 K SR90x5	SR90x2	▲
722511 DA	50	75,5	192	172,5	65	14	170	100	27	12	4,10	1211 K 22211 K	2211 K SR100x6	SR100x2	▲
722511 DB	50	81,5	192	172,5	65	14	170	100	27	12	4,10	1211 K 22211 K	2211 K SR100x6	SR100x2	▲
722512 DA	55	77	210	189	72	14	180	110	30	12	4,80	1212 K 22212 K	2212 K SR110x8	SR110x2	▲
722512 DB	55	82	210	189	72	14	180	110	30	12	4,80	1212 K 22212 K	2212 K SR110x8	SR110x2	▲
722513 DA	60	80	225	203	78	14	190	120	33	12	5,90	1213 K 22213 K	2213 K SR120x10	SR120x2	▲
722513 DB	60	86	225	203	78	14	190	120	33	12	5,90	1213 K 22213 K	2213 K SR120x10	SR120x2	▲
722515 A	65	104	190	190	95	18	152	130	41	16	9,40	1215 K 22215 K	2215 K SR130x8	SR130x10	■
722515 B	65	104	190	190	95	18	152	130	41	16	9,40	1215 K 22215 K	2215 K SR130x8	SR130x10	■
722516 A	70	110	196	196	98	18	152	140	43	16	9,80	1216 K 22216 K	2216 K SR140x8,5	SR140x10	■
722516 B	70	110	196	196	98	18	152	140	43	16	9,80	1216 K 22216 K	2216 K SR140x8,5	SR140x10	■
722517 A	75	114	210	210	105	18	170	150	46	16	11,5	1217 K 22217 K	2217 K SR150x9	SR150x10	■
722517 B	75	114	210	210	105	18	170	150	46	16	11,5	1217 K 22217 K	2217 K SR150x9	SR150x10	■
722518 A	80	118	210	210	105	18	170	160	50	16	12,5	1218 K 22218 K	2218 K SR160x10	SR160x10	■
722518 B	80	118	210	210	105	18	170	160	50	16	12,5	1218 K 22218 K	2218 K SR160x10	SR160x10	■
722520 A	90	127	250	250	125	22	198	180	56	20	18,0	1220 K 22220 K	2220 K SR180x11	SR180x10	■
722520 B	90	127	250	250	125	22	198	180	56	20	18,0	1220 K 22220 K	2220 K SR180x11	SR180x10	■
722522 A	100	137	270	270	135	22	219	200	63	20	21,5	1222 K 22222 K	2222 K SR200x12,5	SR200x10	■
722522 B	100	137	270	270	135	22	219	200	63	20	21,5	1222 K 22222 K	2222 K SR200x12,5	SR200x10	■

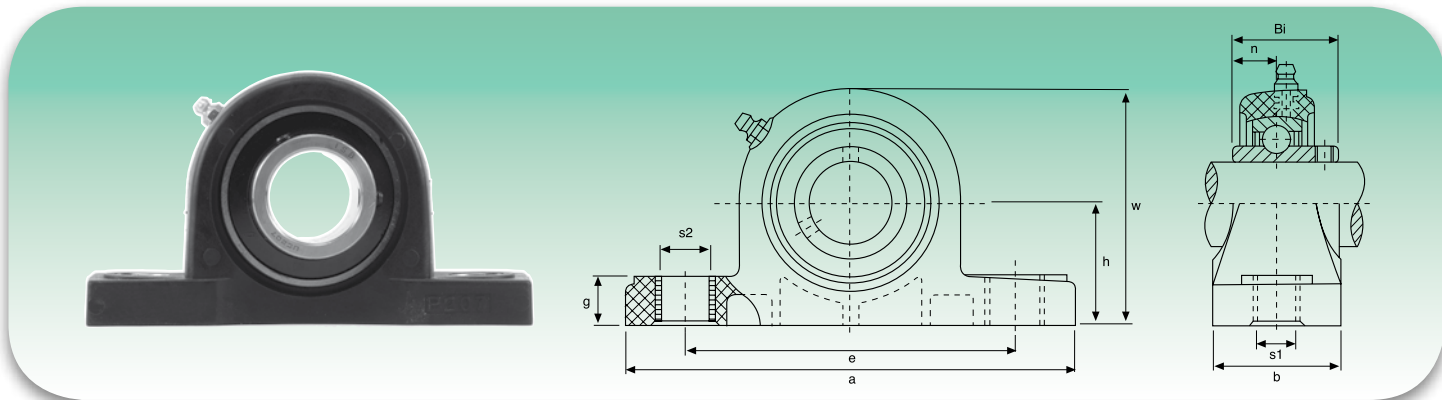

Tipo Type	Diametro albero Shaft diameter		Dimensioni - Dimensions										Peso Weight kg	Bull. fiss. Bolt Size	Coppia (Nm) Torque (Nm)
			a	h	e	b	s1	s2	g	w	Bi	n			
	mm	inch	mm												
UCP 204	20	¾	127	33,3	95	37,5	11	14	14,2	65,5	31	12,7	0,13	M10	18
UCP 205	25	1 ¼ 7/16 1 1/8 1	140,5	36,5	105	38	11	14	14,5	71	34	14,3	0,14	M10	25
UCP 206	30	1 ½ 1 1/8 1 3/8 1 ¼	163	42,9	119	46	15	18	18	84	38,1	15,9	0,24	M12	30
UCP 207	35	1 ¾ 1 5/8 1 7/8 1 7/16	168	47,6	127	48	15	18	18	94,5	42,9	17,5	0,27	M12	35
UCP 208	40	1 ½ 1 9/16	184	49,2	137	54	15	18	20	98	49,2	19	0,35	M12	45
UCP 209	45	1 5/8 1 11/16 1 ¾	192	54	146	54	17	20	25	106	49,2	19	0,41	M16	50
UCP 210	50	1 13/16 1 7/8 1 15/16 2	206	57,2	159	59	17	20	24	114	51,6	19	0,47	M16	55
UCP 211	55	2 2 1/4 2 1/8 2 3/8	219	63,5	171	60	17	20	23	125	55,6	22,2	0,58	M16	60
UCP 212	60	2 ¼ 2 3/8 2 3/4 2 7/8	241	69,8	184	70	17	20	26	136	65,1	25,4	0,68	M16	65

Modalità di caricamento Mode of load	Coefficients di carico (N) - Load ratings (N)									
Tipo Type	204	205	206	207	208	209	210	211	212	
	8 800	13 700	12 650	12 750	13 100	13 360	13 850	14 540	15 270	
	7 700	10 000	10 600	10 800	11 100	11 400	11 750	11 970	12 570	
	5 000	8 100	5 750	7 500	8 500	8 950	9 550	10 027	10 530	

Caratteristiche

- Materiale: PBT (disponibili in color bianco, nero e verde)
- Intercambiabile con supporti in ghisa
- Ingrassatori d'acciaio inox aisi 304
- Temperatura d'esercizio: da -35°C a +102°C
- Coperchio d'estremità
- Guarnizioni interne
- Resistenza chimica (pag. 150)

Characteristics

- Material: PBT (white, black and green colours available)
- Interchangeable with cast iron housing
- Stainless steel aisi 304 greasers
- Working temperature: from -35°C to +102°C
- End cover
- Back seals
- Chemical resistance (pag. 150)

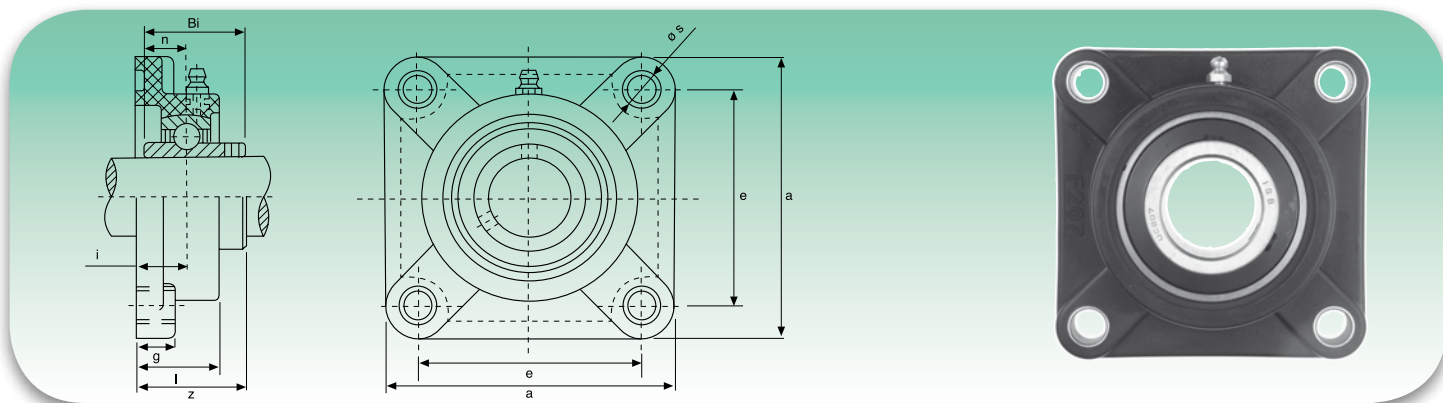

Tipo Type	Diametro albero Shaft diameter		Dimensioni - Dimensions									Peso Weight	Bull. fiss. Bolt Size	Coppia (Nm) Torque (Nm)
			a	e	g	l	s	z	i	Bi	n			
	mm	inch	mm									kg		
UCF 201	12	1/2	86	63,5	13,4	27,8	11	34,6	16,3	31	12,7	0,12	M10	18
UCF 202	15	9/16 5/8	86	63,5	13,4	27,8	11	34,6	16,3	31	12,7	0,12	M10	18
UCF 203	17	11/16	86	63,5	13,4	27,8	11	34,6	16,3	31	12,7	0,12	M10	18
UCF 204	20	3/4	86	63,5	14,5	28	11	34,6	16,3	31	12,7	0,12	M10	18
UCF 205	25	13/16 7/8 15/16 1	95	70	15	29	11	36,7	17	34	14,3	0,15	M10	25
UCF 206	30	1 1/16 1 1/8 1 1/4	107	83	15	31,5	11	41,2	19	38,1	15,9	0,18	M10	30
UCF 207	35	1 1/4 1 5/16 1 3/8 1 7/16	118	92	16	34,5	13	46,9	21,5	42,9	17,5	0,25	M12	35
UCF 208	40	1 1/2 1 5/8	130	102	18	36,5	14	53,2	23	49,2	19	0,36	M12	40
UCF 209	45	1 5/8 1 7/8 1 3/4	137	105	19	41	17	54,2	24	49,2	19	0,42	M16	45
UCF 210	50	1 7/8 1 5/8 1 1/2 2	143	111	21	41	17	57,6	25	51,6	19	0,49	M16	50
UCF 211	55	2 1/16 2 1/8 2 3/16	162	130	20	42	19	58,4	26	55,6	22,2	0,59	M16	55
UCF 212	60	2 1/4 2 5/16 2 3/8 2 7/16	175	142	23	45	19	68,7	27	65,1	25,1	0,71	M16	60

Modalità di caricamento Mode of load	Coefficients di carico (N) - Load ratings (N)									
	Tipo Type	204	205	206	207	208	209	210	211	212
		15 950	13 000	18 000	18 500	19 100	19 350	19 650	20 630	21 660
		10 250	12 150	17 700	18 500	19 250	19 350	19 620	20 600	21 630
		3 650	3 350	3 350	3 520	3 790	3 850	3 990	4 190	4 400

Caratteristiche

- Materiale: PBT (disponibili in color bianco, nero e verde)
- Intercambiabile con supporti in ghisa
- Ingrassatori d'acciaio inox aisi 304
- Temperatura d'esercizio: da -35°C a +102°C
- Coperchio d'estremità
- Guarnizioni interne
- Resistenza chimica (pag. 150)

Characteristics

- Material: PBT (white, black and green colours available)
- Interchangeable with cast iron housing
- Stainless steel aisi 304 greasers
- Working temperature: from -35°C to +102°C
- End cover
- Back seals
- Chemical resistance (pag. 150)

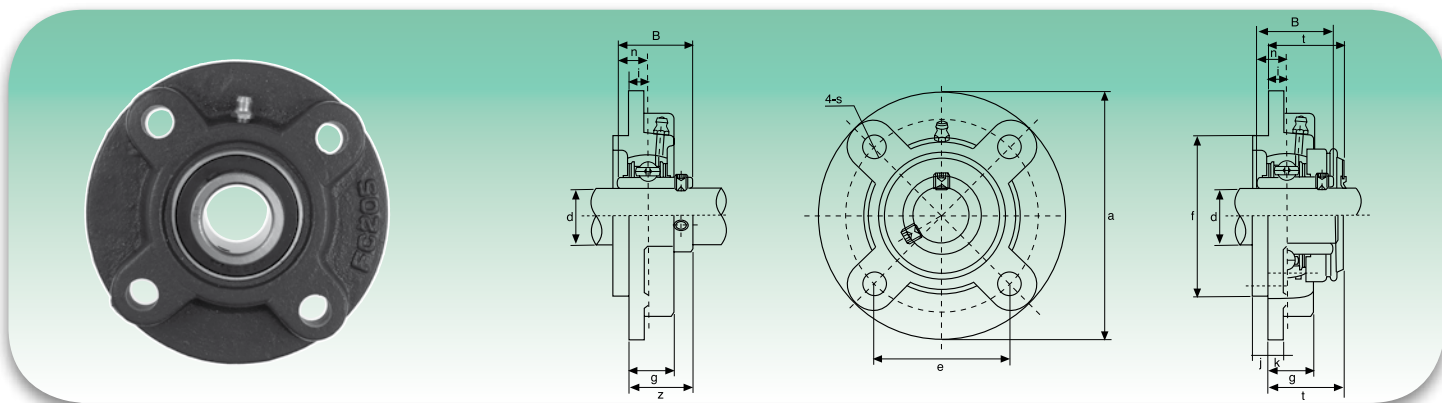
UCFC

Tipo Type	Diametro albero Shaft diameter		Dimensioni - Dimensions								Peso Weight kg	Bull. fiss. Bolt Size	Coppia (Nm) Torque (Nm)
			a	e	g	s	z	i	Bi	n			
	mm	inch	mm										
UCFC 204	20	$\frac{3}{4}$	100	55,1	20,5	12	28,3	10	31	12,7	0,14	M10	18
UCFC 205	25	$\frac{13}{16}$ $\frac{7}{8}$ $1\frac{1}{16}$ 1	115	63,6	21	12	29,7	10	34,1	14,3	0,19	M10	25
UCFC 206	30	$1\frac{1}{16}$ $1\frac{1}{8}$ $1\frac{3}{16}$ $1\frac{1}{4}$	125	70,7	23	12	32,2	10	38,1	15,9	0,26	M10	30
UCFC 207	35	$1\frac{1}{4}$ $1\frac{3}{8}$ $1\frac{1}{2}$ $1\frac{7}{8}$	135	77,8	26	14	36,4	11	42,9	17,5	0,36	M12	35
UCFC 208	40	$1\frac{1}{2}$ $1\frac{5}{8}$	145	84,8	26	14	40,2	11	49,2	19	0,40	M12	40
UCFC 209	45	$1\frac{5}{8}$ $1\frac{7}{8}$ $1\frac{3}{4}$	160	93,3	26	16	41,2	10	49,2	19	0,58	M14	45
UCFC 210	50	$1\frac{7}{8}$ $1\frac{7}{8}$ $1\frac{5}{8}$ 2	165	97,6	28	16	42,6	10	51,6	19	0,58	M14	50
UCFC 211	55	2 $2\frac{1}{16}$ $2\frac{1}{8}$ $2\frac{3}{16}$	185	106,1	31	19	46,4	13	55,6	22,2	-	M16	55
UCFC 212	60	$2\frac{1}{4}$ $2\frac{3}{16}$ $2\frac{1}{2}$ $2\frac{7}{16}$	195	113,1	36	19	56,7	17	65,1	25,4	-	M16	60

Modalità di caricamento Mode of load	Coefficienti di carico (N) - Load ratings (N)									
Tipo Type	204	205	206	207	208	209	210	211	212	
	15 950	13 000	18 000	18 500	19 100	19 350	19 650	20 630	21 660	
	10 250	12 150	17 700	18 500	19 250	19 350	19 620	20 600	21 630	

Caratteristiche

- Materiale: PBT (**disponibili in color bianco, nero e verde**)
- Intercambiabile con supporti in ghisa
- Ingrassatori d'acciaio inox aisi 304
- Temperatura d'esercizio: da -35°C a +102°C
- Coperchio d'estremità
- Guarnizioni interne
- Resistenza chimica (pag. 150)

Characteristics

- Material: PBT (**white, black and green colours available**)
- Interchangeable with cast iron housing
- Stainless steel aisi 304 greasers
- Working temperature: from -35°C to +102°C
- End cover
- Back seals
- Chemical resistance (pag. 150)

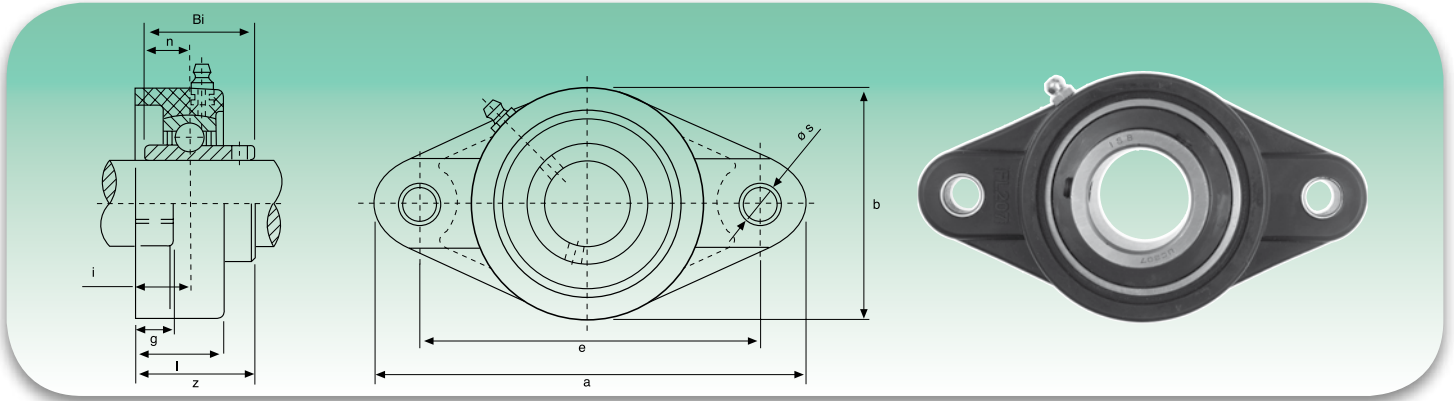

Tipo Type	Diametro albero Shaft diameter		Dimensioni - Dimensions										Peso Weight	Bull. fiss. Bolt Size	Coppia (Nm) Torque (Nm)
			a	e	b	g	l	s	z	i	Bi	n			
	mm	inch	mm										kg		
UCFL 201	12	1/2	113	90	65	13,4	26,5	11	33,3	15	31	12,7	0,08	M10	18
UCFL 202	15	9/16 5/8	113	90	65	13,4	26,5	11	33,3	15	31	12,7	0,08	M10	18
UCFL 203	17	11/16	113	90	65	13,4	26,5	11	33,3	15	31	12,7	0,08	M10	18
UCFL 204	20	3/4	113	90	65	14	26,5	11	33,3	15	31	12,7	0,08	M10	18
UCFL 205	25	13/16 7/8 15/16 1	131	99	70	15	28	11	36,2	16,5	34	14,3	0,11	M10	25
UCFL 206	30	1 1/16 1 1/8 1 3/16 1 1/4	148	117	80	14,3	30,5	11	40,2	18	38,1	15,9	0,13	M10	30
UCFL 207	35	1 1/4 1 5/16 1 3/8 1 7/16	164	130	90	15,5	32	13	44,4	19	42,9	17,5	0,16	M12	35
UCFL 208	40	1 1/2 1 5/8	176	144	100	17	35	14	51,7	21,5	49,2	19	0,22	M12	40
UCFL 209	45	1 5/8 1 7/8 1 3/4	189	149	108	22,5	40,5	17	54,2	24	49,2	19	0,26	M16	45
UCFL 210	50	1 3/4 1 7/8 1 15/16 2	197	157	115	22	41	17	57,6	25	51,6	19	0,31	M16	50
UCFL 211	55	2 2 1/16 2 1/8 2 3/16	224	184	129	18	43	19	58,4	26	55,6	22,2	0,54	M16	55
UCFL 212	60	2 1/4 2 5/16 2 3/8 2 7/16	250	202	140	24	45	19	68,7	27	65,1	25,4	0,56	M16	60

Modalità di caricamento Mode of load	Coefficients di carico (N) - Load ratings (N)									
	Tipo Type	204	205	206	207	208	209	210	211	212
		11 750	11 375	16 450	16 900	17 350	17 600	17 950	18 850	19 790
		11 000	13 850	13 350	13 950	14 050	14 300	14 550	15 280	16 040
		8 500	11 100	14 200	14 900	15 150	15 350	15 650	16 430	17 250

Caratteristiche

- Materiale: PBT (**disponibili in color bianco, nero e verde**)
- Intercambiabile con supporti in ghisa
- Ingrassatori d'acciaio inox aisi 304
- Temperatura d'esercizio: da -35°C a +102°C
- Coperchio d'estremità
- Guarnizioni interne
- Resistenza chimica (pag. 150)

Characteristics

- Material: PBT (**white, black and green colours available**)
- Interchangeable with cast iron housing
- Stainless steel aisi 304 greasers
- Working temperature: from -35°C to +102°C
- End cover
- Back seals
- Chemical resistance (pag. 150)

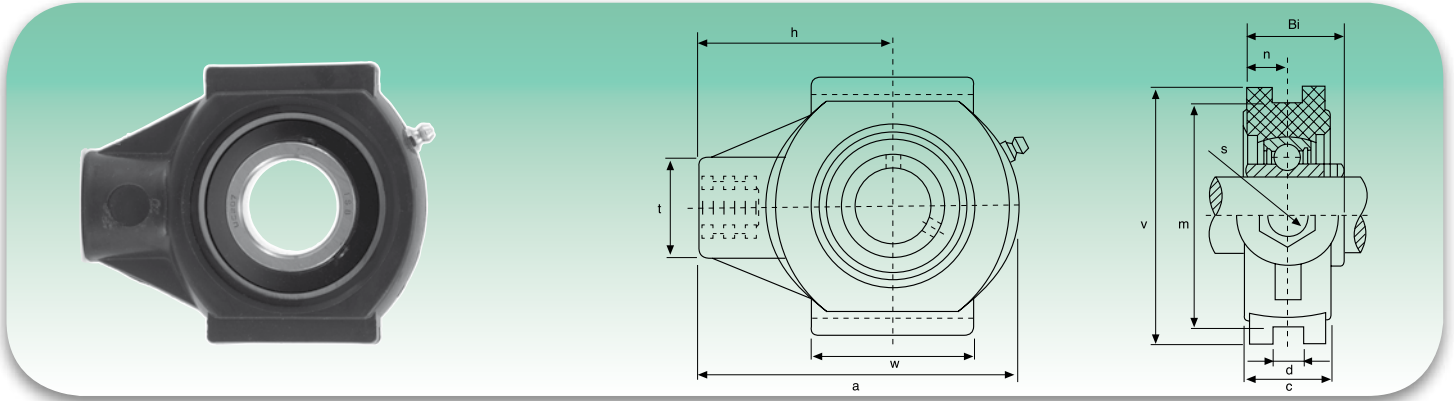
UCT

Tipo Type	Diametro albero Shaft diameter		Dimensioni - Dimensions										Peso Weight	Bull. fss. Bolt Size
			a	c	d	h	m	t	v	w	Bi	n		
	mm	inch	mm										kg	S
UCT 201	12	1/2	99	27,5	12	64	76	36	88	47	31	11,5	0,18	M16
UCT 202	15	9/16 5/8	99	27,5	12	64	76	36	88	47	31	11,5	0,18	M16
UCT 203	17	11/16	99	27,5	12	64	76	36	88	47	31	11,5	0,18	M16
UCT 204	20	3/4	99	27,5	12	64	76	36	88	47	31	11,5	0,18	M16
UCT 205	25	13/16 7/8 15/16 1	99	27,5	12	64	76	36	88	47	34,1	11,5	0,18	M16
UCT 206	30	1 1/16 1 1/8 1 1/4	125	34	12	76	89	40	102	63	38,1	15,9	0,28	M16
UCT 207	35	1 1/4 1 3/16 1 3/8 1 7/16	125	34	12	76	89	40	102	63	42,9	15,9	0,28	M16
UCT 208	40	1 1/2 1 9/16	140	40	16	85	102	40	113	80	49,2	19	0,36	M16
UCT 209	45	1 5/8 1 11/16 1 3/4	149	40	16	90	102	50	117	85	49,2	19	0,41	M20
UCT 210	50	1 7/8 1 7/8 1 15/16 2	149	40	16	90	102	50	117	85	51,6	19	0,47	M20
UCT 211	55	2 2 1/16 2 1/8 2 3/16	171	38	22	106	130	64	146	95	55,6	19	-	M20
UCT 212	60	2 1/4 2 3/16 2 3/8 2 7/16	194	42	22	119	130	64	146	102	65,1	21	-	M20

Modalità di caricamento Mode of load	Coefficienti di carico (N) - Load ratings (N)									
Tipo Type	204	205	206	207	208	209	210	211	212	
	14 800	15 500	15 800	16 500	17 300	18 210	18 860	19 800	20 790	
	3 930	4 530	5 100	6 500	7 800	8 710	9 750	10 240	10 750	
	8 500	10 350	10 900	11 300	12 150	12 900	13 550	14 230	14 940	
	40 770	45 300	46 100	44 100	42 800	44 230	44 880	47 120	49 470	

Caratteristiche

- Materiale: PBT (**disponibili in color bianco, nero e verde**)
- Intercambiabile con supporti in ghisa
- Ingrassatori d'acciaio inox aisi 304
- Temperatura d'esercizio: da -35°C a +102°C
- Coperchio d'estremità
- Guarnizioni interne
- Resistenza chimica (pag. 150)

Characteristics

- Material: PBT (**white, black and green colours available**)
- Interchangeable with cast iron housing
- Stainless steel aisi 304 greasers
- Working temperature: from -35°C to +102°C
- End cover
- Back seals
- Chemical resistance (pag. 150)

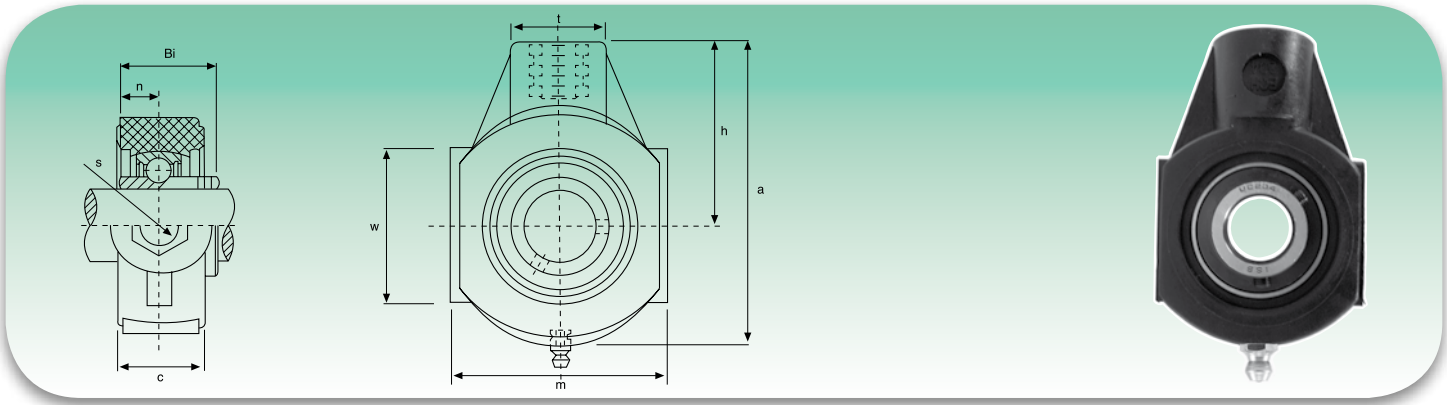

Tipo Type	Diametro albero Shaft diameter		Dimensioni - Dimensions								Peso Weight	Bull. fiss. Bolt Size
			a	c	h	m	t	w	Bi	n		
	mm	inch	mm								kg	S
UCECH 201	12	1/2	99	27,5	63,5	65	36	47	31	12,7	0,18	M16
UCECH 202	15	9/16 5/8	99	27,5	63,5	65	36	47	31	12,7	0,18	M16
UCECH 203	17	11/16	99	27,5	64	65	36	47	31	12,7	0,18	M16
UCECH 204	20	3/4	99	23	64	65	36	46	31	12,7	0,18	M16
UCECH 205	25	13/16 7/8 15/16 1	99	24	63,5	74	36	47	34	14,3	0,17	M16
UCECH 206	30	1 1/16 1 1/8 1 3/16 1 1/4	125	27,5	76	90	40	63	38,1	15,9	0,27	M16
UCECH 207	35	1 1/4 1 5/16 1 3/8 1 7/16	125	28	76	90	40	63	42,9	17,5	0,28	M16
UCECH 208	40	1 1/2 1 9/16	140	29	85	100	40	80	49,2	19	0,36	M16
UCECH 209	45	1 5/8 1 11/16 1 3/4	149	40	90	110	50	85	49,2	19	0,41	M20
UCECH 210	50	1 7/8 1 7/8 1 15/16 2	149	40	90	110	50	85	51,6	19	0,47	M20
UCECH 211	55	2 2 1/16 2 1/8 2 3/16	171	38	106	140	64	95	55,6	22,2	-	M20
UCECH 212	60	2 1/4 2 5/16 2 3/8 2 7/16	194	42	119	140	64	102	65,1	25,4	-	M20

Modalità di caricamento Mode of load	Coefficients di carico (N) - Load ratings (N)									
Tipo Type	204	205	206	207	208	209	210	211	212	
	14 800	15 500	15 800	16 500	17 300	18 210	18 860	19 800	20 790	
	3 930	4 530	5 100	6 500	7 800	8 710	9 750	10 240	10 750	
	8 500	10 350	10 900	11 300	12 150	12 900	13 550	14 230	14 940	
	40 770	45 300	46 100	44 100	42 800	44 230	44 880	47 120	49 470	

Caratteristiche

- Materiale: PBT (disponibili in color bianco, nero e verde)
- Intercambiabile con supporti in ghisa
- Ingrassatori d'acciaio inox aisi 304
- Temperatura d'esercizio: da -35°C a +102°C
- Coperchio d'estremità
- Guarnizioni interne
- Resistenza chimica (pag. 150)

Characteristics

- Material: PBT (white, black and green colours available)
- Interchangeable with cast iron housing
- Stainless steel aisi 304 greasers
- Working temperature: from -35°C to +102°C
- End cover
- Back seals
- Chemical resistance (pag. 150)

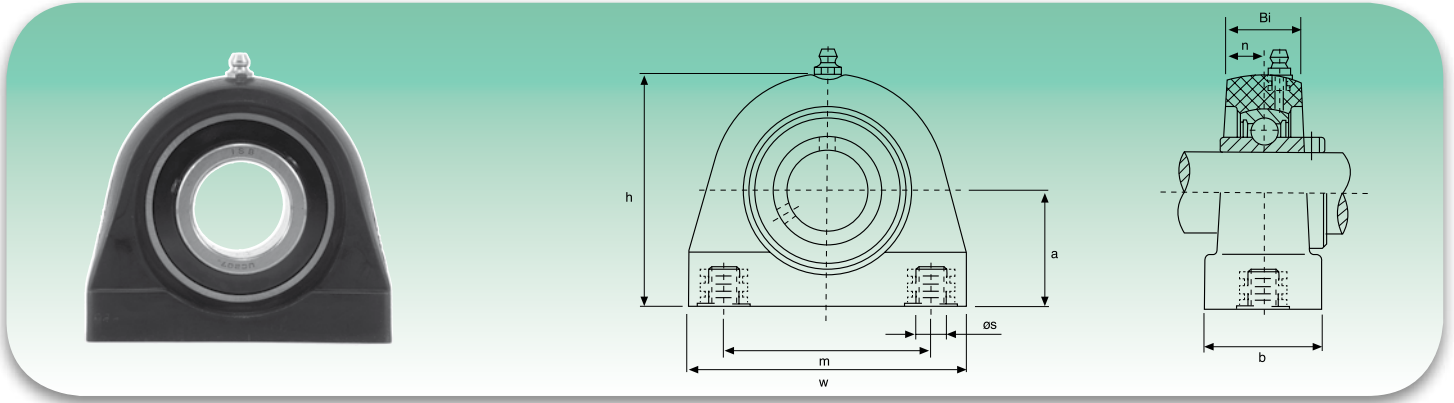
UCPA

Tipo Type	Diametro albero Shaft diameter		Dimensioni - Dimensions							Peso Weight	Bull. fiss. Bolt Size	Coppia (Nm) Torque (Nm)
			a	b	h	m	w	Bi	n		S	
	mm	inch								mm		
UCPA 201	12	1/2	33,3	34,5	66	50,8	72,8	31	12,7	0,085	M8	18
UCPA 202	15	9/16 5/8	33,3	34,5	66	50,8	72,8	31	12,7	0,085	M8	18
UCPA 203	17	11/16	33,3	34,5	66	50,8	72,8	31	12,7	0,085	M8	18
UCPA 204	20	3/4	33,3	34,5	66	50,8	72,8	31	12,7	0,085	M8	18
UCPA 205	25	13/16 7/8 15/16 1	36,5	39,5	73,5	50,8	76,2	34,1	14,3	0,115	M10	25
UCPA 206	30	1 1/16 1 1/8 1 1/4	42,9	42	84	76,2	101	38,1	15,9	0,17	M10	30
UCPA 207	35	1 1/4 1 3/8 1 7/8	47,6	47	95	82,6	110,5	42,9	17,5	0,25	M10	35
UCPA 208	40	1 1/2 1 5/8	49,2	48	100,5	88,9	120	49,2	19	0,29	M12	45
UCPA 209	45	1 5/8 1 7/8 1 3/4	54	49,5	108,5	95,3	124	49,2	19	0,34	M12	50
UCPA 210	50	1 7/8 1 7/8 1 7/8 2	57,2	53	115	101,6	136,5	51,6	19	0,43	M16	55
UCPA 211	55	2 2 1/4 2 1/2 2 3/8	140	66	63,5		125	55,6	22,2	1,43	M20	60
UCPA 212	60	2 1/4 2 3/8 2 3/8 2 7/8	150	68	69,9		138	65,1	25,4	1,58	M20	65

Modalità di caricamento Mode of load	Coefficienti di carico (N) - Load ratings (N)									
Tipo Type	204	205	206	207	208	209	210	211	212	
	8 210	8 540	10 370	12 150	12 230	12 900	13 850	14 540	15 270	
	6 900	7 010	6 580	8 080	9 100	10 400	11 050	11 600	12 180	
	2 980	2 850	4 950	8 160	9 800	10 710	11 360	11 930	12 530	

Caratteristiche

- Materiale: PBT (**disponibili in color bianco, nero e verde**)
- Intercambiabile con supporti in ghisa
- Ingrassatori d'acciaio inox aisi 304
- Temperatura d'esercizio: da -35°C a +102°C
- Coperchio d'estremità
- Guarnizioni interne
- Resistenza chimica (pag. 150)

Characteristics

- Material: PBT (**white, black and green colours available**)
- Interchangeable with cast iron housing
- Stainless steel aisi 304 greasers
- Working temperature: from -35°C to +102°C
- End cover
- Back seals
- Chemical resistance (pag. 150)

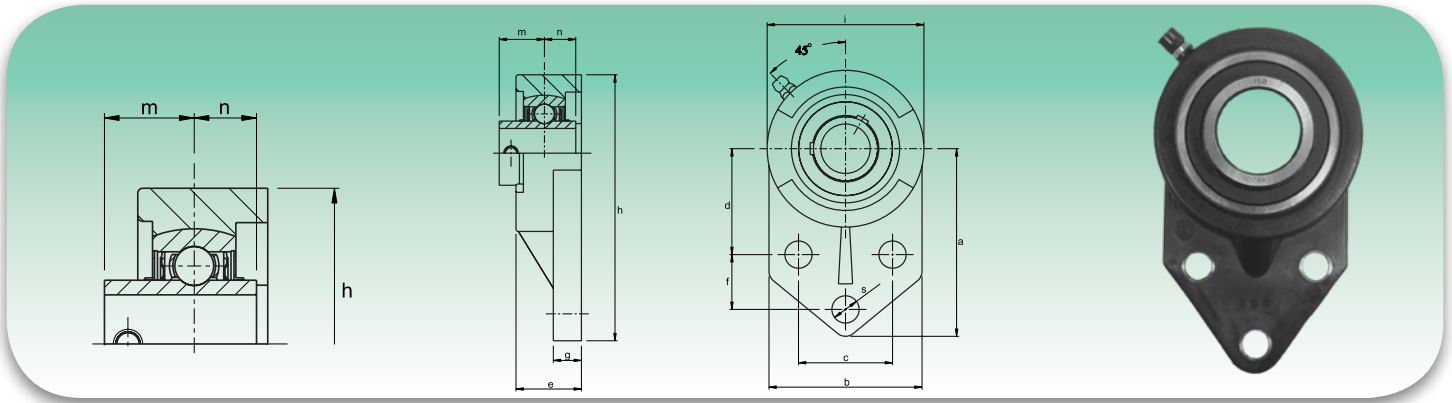

Tipo Type	Diametro albero Shaft diameter		Dimensioni - Dimensions											Peso Weight kg	Bull. fiss. Bolt Size	Coppia Torque (Nm)	
			a	b	c	d	e	f	g	h	i	k	m				n
	mm	inch	mm														
UCFB 201	12	1/2	76	62	38,1	42,9	26,5	22,2	11,4	108	63,5	11	18,3	12,7	0,08	M10	18
UCFB 202	15	9/16 5/8	76	62	38,1	42,9	26,5	22,2	11,4	108	63,5	11	18,3	12,7	0,08	M10	18
UCFB 203	17	11/16	76	62	38,1	42,9	26,5	22,2	11,4	108	63,5	11	18,3	12,7	0,08	M10	18
UCFB 204	20	3/4	76	62	38,1	42,9	26,5	22,2	11,4	108	63,5	11	18,3	12,7	0,08	M10	18
UCFB 205	25	13/16 7/8 15/16 1	85,7	63,5	41,3	46	28	28,6	11,4	121	70	11	19,7	14,3	0,11	M10	25
UCFB 206	30	1 1/16 1 1/8 1 3/16 1 1/4	95	76	47,6	52,4	32	31,8	13	138,5	83	11	22,2	15,9	0,16	M10	30
UCFB 207	35	1 1/4 1 5/16 1 3/8 1 7/16	108	89	50,8	60,3	36,5	31,8	16	157	95	13	25,4	17,5	0,23	M12	35
UCFB 208	40	1 1/2 1 5/8	114	77	50	60,3	35	41,3	16	163	100	13	30,2	19	0,30	M12	40
UCFB 209	45	1 5/8 1 11/16 1 3/4	121	80	54	65	35	43	18	174	106	17	30,2	19	0,34	M12	45
UCFB 210	50	1 13/16 1 7/8 1 15/16 2	128	86	58	68	35	46	18	184	112	17	32,6	19	0,40	M12	50
UCFB 211	55	2 2 1/8 2 1/16 2 3/16	-	90	62	78	43	50	18	207	130	16	33,4	22,2	-	M14	55
UCFB 212	60	2 1/4 2 5/16 2 3/8 2 7/16	-	94	66	84	48	55	18	223	140	16	39,7	25,4	-	M14	60

Modalità di caricamento Mode of load	Coefficienti di carico (N) - Load ratings (N)									
Tipo Type	201	202	203	204	205	206	207	211	212	
	-	-	-	7 200	9 100	12 200	12 900	13 540	14 200	
	-	-	-	9 200	11 100	11 800	11 900	12 500	13 120	
	-	-	-	2 600	2 800	2 900	3 100	3 250	3 410	

Caratteristiche

- Materiale: PBT (disponibili in color bianco, nero e verde)
- Intercambiabile con supporti in ghisa
- Ingrassatori d'acciaio inox aisi 304
- Temperatura d'esercizio: da -35°C a +102°C
- Coperchio d'estremità
- Guarnizioni interne
- Resistenza chimica (pag. 150)

Characteristics

- Material: PBT (white, black and green colours available)
- Interchangeable with cast iron housing
- Stainless steel aisi 304 greasers
- Working temperature: from -35°C to +102°C
- End cover
- Back seals
- Chemical resistance (pag. 150)

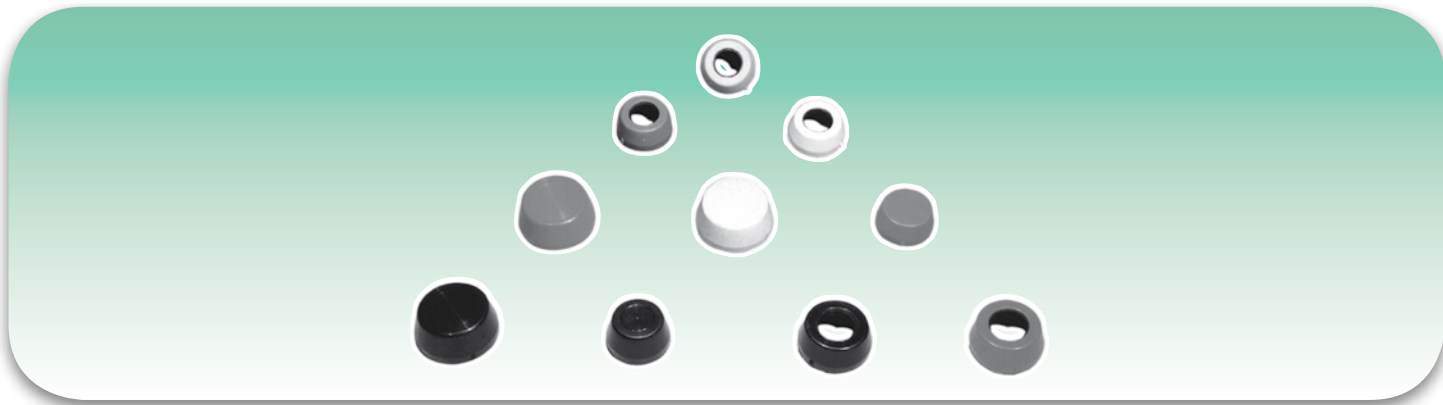
Caratteristiche

- Materiale: Polipropilene (SR 50)
- Approvato FDA
- Coperchio aperto con anello in acciaio inox
- Gamma colori a richiesta

Characteristics

- Material: Polypropylen (SR 50)
- FDA approved
- Open cover with stainless steel ring
- Range of colours on request

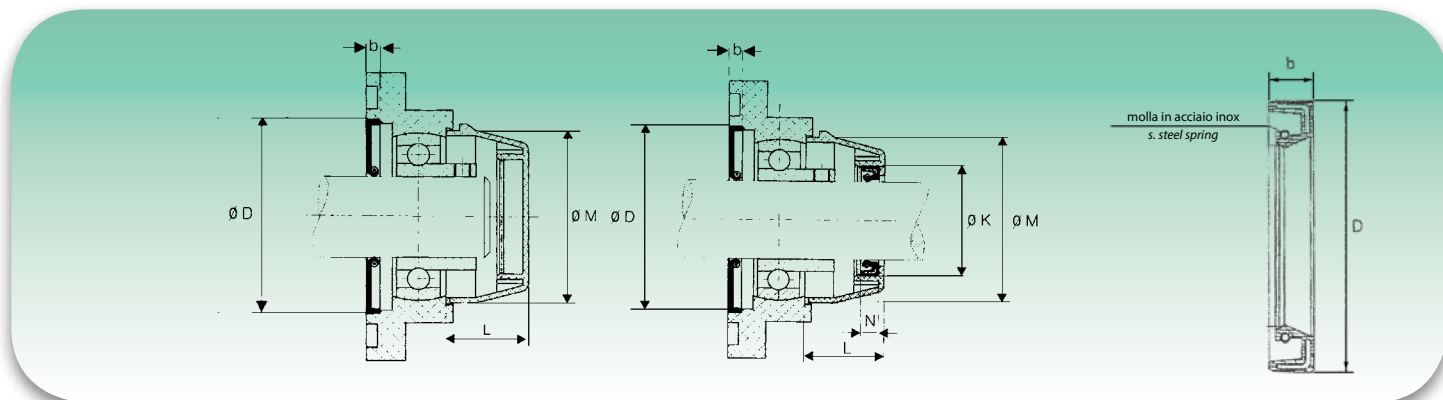

Diametro albero Shaft diameter		Dimensioni - Dimensions					Guarnizione interna - Backseal		
		K	N	L	M	D	b	D	
mm	inch	mm							
12	1/2	32	7	23	50	52	6	3	52
15	9/16 5/8	32	7	23	50	52	6	3	52
17	11/16	32	7	23	50	52	6	3	52
20	3/4	32	7	23	50	52	6	3	52
25	13/16 7/8 15/16 1	37	7	25	55	62	6	3	62
30	1 1/16 1 1/8 1 3/16 1 1/4	42	7	30	64	72	6	3	72
35	1 1/4 1 5/16 1 3/8 1 7/16	47	7	32	74,5	82	6	3	82
40	1 1/2 1 5/8	52	7	37	84	88	6	3	88
45	1 5/8 1 7/8 1 3/4	57	7	41	89	93	6	3	93
50	1 3/4 1 7/8 1 5/4 2	62	7	47	94	98	6	3	98
55	2 1/8 2 1/16 2 3/16	66	9	56	100	106	6	3	108
60	2 1/4 2 5/16 2 3/8 2 7/16	72	9	60	114	116	6	3	117

Con cuscinetto UC non si può montare la tenuta posteriore nei supporti plastici, montaggio fattibile con cuscinetti SB
 With UC bearing don't use the rear seal in the plastic bearing units, feasible assembly only with SB bearings

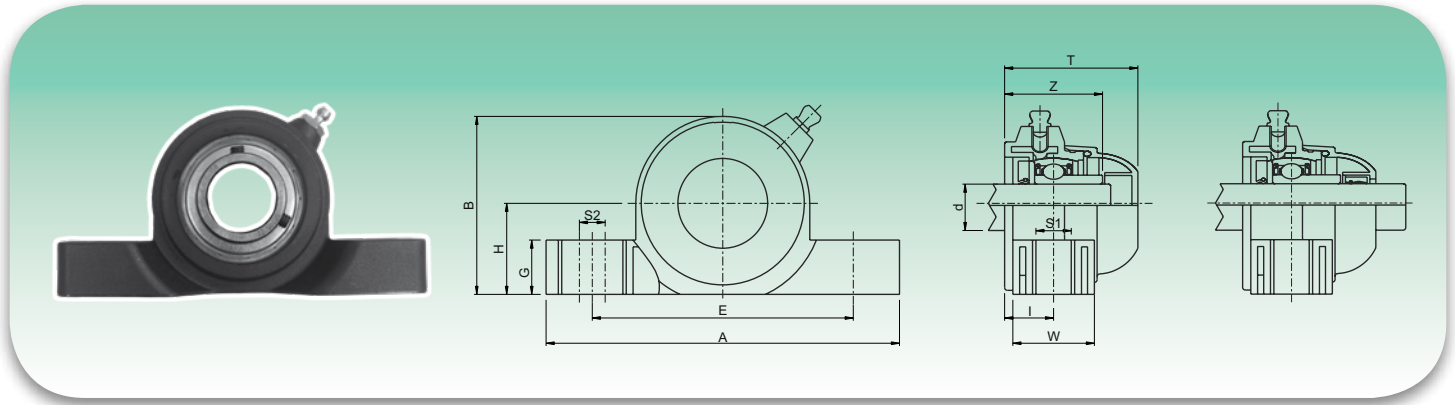

Tipo Type	Diametro albero Shaft diameter	Dimensioni - Dimensions											Carico cuscinetto Bearing load		Carico supporto Bearing units load
		E	A	S1	S2	G	H	B	I	W	Z	T	C (N)	C0 (N)	(N)
		mm													
SBP 204	20	96	130	13	10	20	33,5	65,5	18	30	36	49	12800	6600	5750
SBP 205	25	106	140	13	10	20	36,5	71,5	19,6	35	39	51,7	14000	7800	6900
SBP 206	30	121	163	13	10	20	43	84,5	20,7	36	41,7	55,7	19500	11300	9200
SBP 20	35	126	168	13	10	20	47,6	93,3	22,7	39	48	61,8	25500	15300	11500

Caratteristiche

- Corpo esterno supporto in poliammide rinforzata con fibre di vetro
- Guarnizioni anteriori e posteriori a tenuta stagna NBR per alberi rotanti
- Distanziale di rinforzo fissaggi in acciaio inox AISI 304
- Guarnizione OR in gomma NBR
- Ingrassatore per la rilubrificazione in ottone nichelato
- Grani di bloccaggio con sfera per una maggiore tenuta
- Fori di fissaggio intercambiabili con serie leggera

Characteristics

- Bearing unit body made out of polyamide reinforced with glass fibers
- Front and back seals made out of NBR rubber for turning shaft seal
- Spacer for fixing reinforcement made out of stainless steel AISI 304
- OR seals made out of NBR rubber
- Greaser for relubrication made out of nickel-plated brass
- Setscrews with ball for a perfect endurance
- Interchangeable fixing holes with light series

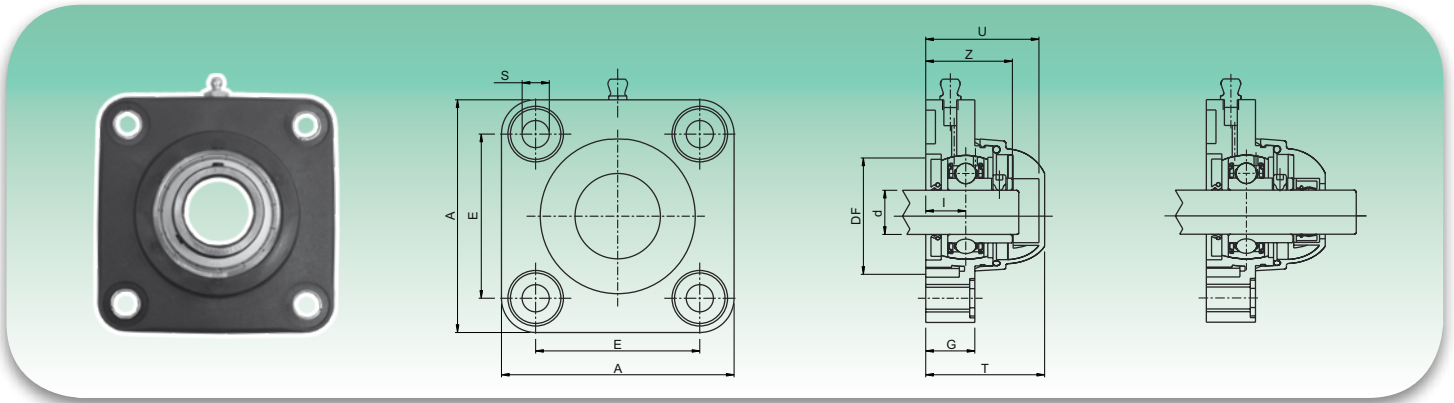

Tipo Type	Diametro albero Shaft diameter	Dimensioni - Dimensions										Carico cuscinetto Bearing load		Carico supporto Bearing units load
		E	A	S	G	I	Z	U	T	DF		C (N)	CO (N)	(N)
		mm										min	max	
SBF 204	20	63,5	90	10,5	19	15,5	33,5	44	46,5	40	45	12800	6600	16500
SBF 205	25	70	99	10,5	22	17	36	47	49	45	50	14000	7800	17000
SBF 206	30	83	113	10,5	26	20	41	54	56	50	60	19500	11300	17500
SBF 207	35	92	122	10,5	26	20	45	57	59	55	70	25500	15300	18000
SBF 208	40	102	133	10,5	26	19,5	48,5	65	68	78	65	32500	19800	18000

Caratteristiche

- Corpo esterno supporto in poliammide rinforzata con fibre di vetro
- Guarnizioni anteriori e posteriori a tenuta stagna NBR per alberi rotanti
- Distanziale di rinforzo fissaggi in acciaio inox AISI 304
- Guarnizione OR in gomma NBR
- Ingrassatore per la rilubrificazione in ottone nichelato
- Grani di bloccaggio con sfera per una maggiore tenuta
- Fori di fissaggio intercambiabili con serie leggera

Characteristics

- Bearing unit body made out of polyamide reinforced with glass fibers
- Front and back seals made out of NBR rubber for turning shaft seal
- Spacer for fixing reinforcement made out of stainless steel AISI 304
- OR seals made out of NBR rubber
- Greaser for relubrication made out of nickel-plated brass
- Setscrews with ball for a perfect endurance
- Interchangeable fixing holes with light series

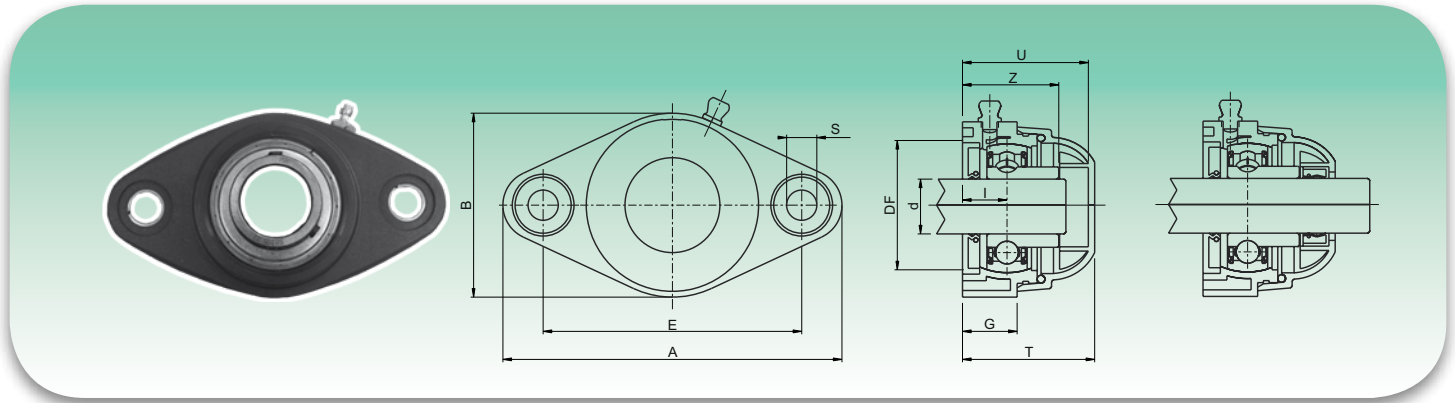

Tipo Type	Diametro albero Shaft diameter	Dimensioni - Dimensions											Carico cuscinetto Bearing load		Carico supporto Bearing units load
		E	A	B	S	G	I	Z	U	T	DF		C (N)	Co (N)	(N)
		mm											min	max	
SBFL 204	20	90	118	64	10,5	19	15,5	33,5	44	46,5	40	45	12800	6600	8500
SBFL 205	25	99	131	72	10,5	22	17	36	47	49	45	50	14000	7800	10000
SBFL 206	30	117	149	86	10,5	26	20	41	54	56	50	60	19500	11300	13000
SBFL 207	35	130	163	94	10,5	26	20	45	57	59	55	70	25500	15300	14000
SBFL 208	40	144	172	100	10,5	27	19,5	48,5	65,5	71	65	78	30700	19000	15000

Caratteristiche

- Corpo esterno supporto in poliammide rinforzata con fibre di vetro
- Guarnizioni anteriori e posteriori a tenuta stagna NBR per alberi rotanti
- Distanziale di rinforzo fissaggi in acciaio inox AISI 304
- Guarnizione OR in gomma NBR
- Ingrassatore per la rilubrificazione in ottone nichelato
- Grani di bloccaggio con sfera per una maggiore tenuta
- Fori di fissaggio intercambiabili con serie leggera

Characteristics

- Bearing unit body made out of polyamide reinforced with glass fibers
- Front and back seals made out of NBR rubber for turning shaft seal
- Spacer for fixing reinforcement made out of stainless steel AISI 304
- OR seals made out of NBR rubber
- Greaser for relubrication made out of nickel-plated brass
- Setscrews with ball for a perfect endurance
- Interchangeable fixing holes with light series

**Caratteristiche**

- Coperchio di protezione in polipropilene

Characteristics

- Protection cover made out of polypropylene

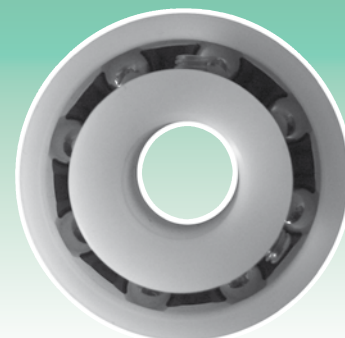
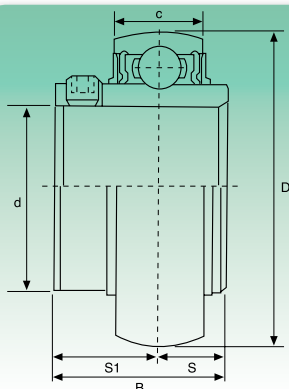

Tipo Type	Dimensioni - Dimensions						Carico Kg. cuscinetto (daN) (Kp) Rating load bearing (daN) (Kp)		Numero di giri max./min. Speed max. r.p.m.	Peso Weight kg
	d	D	B	C	S ₁	S	Dinamico Dynamic	Statico Static		
	mm/inch									
UC 200	10 ¾	47 1,8504	31 1,2205	17 0,6693	18,3 0,720	12,7 0,500	42	27	1050	0,30
UC 201 UC 201-8	12 ¾	47 1,8504	31 1,2205	17 0,6693	18,3 0,720	12,7 0,500	42	27	1050	0,30
UC 202 UC 202-9 UC 202-10	15 ¾ 5/8	47 1,8504	31 1,2205	17 0,6693	18,3 0,720	12,7 0,500	42	27	1050	0,30
UC 203 UC 203-11	17 1 1/16	47 1,8504	31 1,2205	17 0,6693	18,3 0,720	12,7 0,500	42	27	1050	0,30
UC 204 UC 204-12	20 ¾	47 1,8504	31 1,2205	17 0,6693	18,3 0,720	12,7 0,500	42	27	1050	0,30
UC 205 UC 205-13 UC 205-14 UC 205-15 UC 205-16	25 1 3/16 7/8 1 1/16 1	52 2,0472	34,1 1,3425	17 0,6693	19,8 0,780	14,3 0,563	48	32	950	0,46
UC 206 UC 206-17 UC 206-18 UC 206-19 UC 206-20	30 1 1/16 1 1/8 1 3/16 1 1/4	62 2,4409	38,1 1,5000	19 0,7480	22,2 0,874	15,9 0,626	55	36	800	0,69
UC 207 UC 207-20 UC 207-21 UC 207-22 UC 207-23	35 1 1/4 1 5/16 1 3/8 1 7/16	72 2,8346	42,9 1,6890	20 0,7874	25,4 1,000	17,5 0,689	62	41	700	0,89
UC 208 UC 208-24 UC 208-25	40 1 1/2 1 5/8	80 3,1496	49,2 1,9370	22 0,8661	30,2 1,189	19 0,748	66	44	625	1,08

Disponibile anche:

Cuscinetti a sfere in acciaio inox (AISI 440C o 420C)

Cuscinetti a sfere in acciaio (Cromo 100CR6 - SAE 52100)

Per misure e carichi vedere a pagina 102

I cuscinetti sono di tipo aperto nella versione standard, sono anche disponibili con protezione singola e doppia. I valori riportati nella sopra indicata tabella si riferiscono a cuscinetti a sfere con anelli in resina acetalica (POM).

Available also:

Stainless steel bearings (AISI 440C or 420C)

Chrome steel bearings (Chrome 100CR6 - SAE 52100)

For size and load see page 102

In standard version, the bearing are open, but can also be supplied in one or double shield version. The load capacities and speed limits stated in the table above, apply only to ball bearings with ring of polyacetal (POM).

SA

Suffisso UNF: Misure in pollici dei grani di bloccaggio
UNF suffix: inch sizes set screws

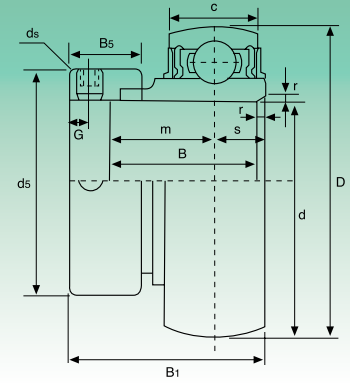

Tipo Type	Dimensioni - Dimensions												Carico Kg. cuscinetto (daN) (Kp) Rating load bearing (daN) (Kp)		Peso Weight kg
	d	c	D	B	r	s	m	B ₁	d _s	B _s	G	d ₅	Dinamico Dynamic	Statico Static	
	mm/inch														
SA 204	20	14	47	21,5	1,5	7	14,5	31	33,3	13,5	5	M6x0,75	60,6	37,8	0,10
SA 204-12	$\frac{3}{4}$	0,5512	1,8504	0,8465	0,0591	0,2756	0,5709	1,2205	1,3110	0,5315	0,1969	-			
SA 205	25	15	52	21,5	1,5	7,5	14	31	38,1	13,5	5	M6x0,75	66	42,6	0,11
SA 205-13	$\frac{1}{16}$	0,5906	2,0472	0,8465	0,0591	0,2953	0,5512	1,2205	1,5000	0,5315	0,1969	-			
SA 205-14	$\frac{7}{8}$														
SA 205-15	$\frac{1}{16}$														
SA 205-16	1														
SA 206	30												16	62	23,8
SA 206-17	$\frac{1}{16}$	0,6299	2,4409	0,9370	0,0591	0,3150	0,6220	1,4055	1,7520	0,6260	0,2362	$\frac{5}{16}$ 24 UNF			
SA 206-18	$\frac{1}{8}$														
SA 206-19	$\frac{1}{16}$														
SA 206-20	$\frac{1}{4}$														
SA 207	35												17	72	25,4
SA 207-20	$\frac{1}{4}$	0,6693	2,8346	1,000	0,0787	0,3346	0,6654	1,5315	2,1890	0,6890	0,2560	$\frac{5}{16}$ 24 UNF			
SA 207-21	$\frac{1}{16}$														
SA 207-22	$\frac{1}{8}$														
SA 207-23	$\frac{1}{16}$														
SA 208	40												19	80	30,2
SA 208-24	$\frac{1}{2}$	0,7480	3,1496	1,1890	0,0787	0,3740	0,8346	1,7205	2,3740	0,7205	0,2560	$\frac{5}{16}$ 24 UNF			
SA 208-25	$\frac{1}{16}$														
SA 209	45												19	85	30,2
SA 209-26	$\frac{1}{8}$	0,7480	3,3465	1,1890	0,0787	0,3740	0,8150	1,7205	2,5000	0,7205	0,2560	$\frac{5}{16}$ 24 UNF			
SA 209-27	$\frac{1}{16}$														
SA 209-28	$\frac{3}{4}$														
SA 210	50												20	90	30,2
SA 210-29	$\frac{1}{16}$	0,7874	3,5433	1,1890	0,0787	0,3937	0,8346	1,7205	2,7520	0,7205	0,2560	-			
SA 210-30	$\frac{1}{8}$														
SA 210-31	$\frac{1}{16}$														
SA 210-32	2														

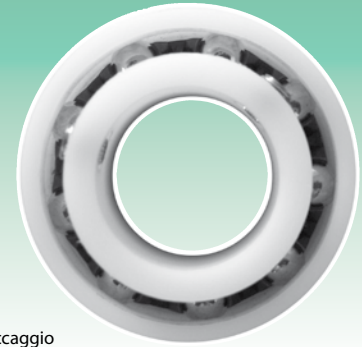
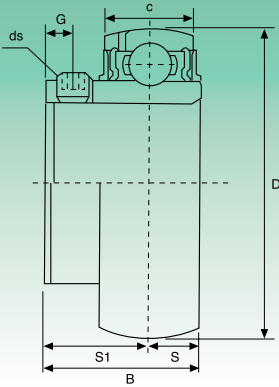

Suffisso UNF: Misure in pollici dei grani di bloccaggio
UNF suffix: inch sizes set screws

Tipo Type	Dimensioni - Dimensions								Carico Kg. cuscinetto (daN) (Kp) Rating load bearing (daN) (Kp)		Peso Weight kg
	d	c	D	B	s	S ₁	G	ds	Dinamico Dynamic	Statico Static	
	mm/inch										
SB 204	20	14	47	25	7	18	4,5	M6x0,75	60,6	37,8	0,08
SB 204-12	¾	0,5512	1,8504	0,9843	0,2756	0,7087	0,1772	-			
SB 205	25	15	52	27	7,5	19,5	5	M6x0,75	66	42,6	0,10
SB 205-13	1⅜	0,5906	2,0472	1,0630	0,2953	0,7677	0,1969	-			
SB 205-14	7/8										
SB 205-15	15/16										
SB 205-16	1										
SB 206	30								16	62	30
SB 206-17	1⅞	0,6299	2,4409	1,1811	0,3150	0,8661	0,2165	-			
SB 206-18	1⅝										
SB 206-19	1⅜										
SB 206-20	1¼										
SB 207	35								17	72	32
SB 207-20	1¼	0,6693	2,8346	1,2598	0,3346	0,9252	0,2362	5/16 24 UNF			
SB 207-21	1⅜										
SB 207-22	1⅝										
SB 207-23	1⅞										
SB 208	40								19	80	34
SB 208-24	1½	0,7480	3,1496	1,3386	0,3740	0,9843	0,3150	5/16 24 UNF			
SB 208-25	1⅞										
SB 209	45	19	85	41,2	10,2	31	8	M8x1	154,2	108,6	0,48
SB 209-26	1⅝	0,7480	3,3465	1,6220	0,4016	1,2205	0,3150	5/16 24 UNF			
SB 209-27	11/16										
SB 209-28	1¾										
SB 210	50								20	90	43,5
SB 210-29	1⅜	0,7874	3,5433	1,7126	0,4291	1,2835	0,3543	-			
SB 210-30	1⅞										
SB 210-31	1⅝										
SB 210-32	2										

Proprietà tipiche del PBT
Typical properties of PBT

Proprietà meccaniche <i>Mechanicals properties</i>	Unità <i>Unit</i>	Metodo per il test <i>Method test</i>	Valori <i>Value</i>
Resistenza alla trazione prima della deformazione prima della rottura <i>Tensile strenght at yield at break</i>	N/mm ² N/mm ²	ASTM D 638 ASTM D 638	115 -
Allungamento relativo prima della deformazione prima della rottura <i>Elongation at yield at break</i>	% %	ASTM D 638 ASTM D 638	3 -
Modulo elastico a trazione <i>Tensile modulus</i>	N/mm ² N/mm ²	ASTM D 638 ASTM D 638	8000 8000
Resistenza alla flessione prima della deformazione <i>Flexural yield strenght</i>	N/mm ² N/mm ²	ASTM D 790 ASTM D 790	170 170
Modulo di rigidità flessionale <i>Flexural modulus</i>	N/mm ² N/mm ²	ASTM D 790 ASTM D 790	7000 7000
Resistenza all'impatto ad intaglio Charpy <i>Notched impact strenght Charpy</i>	K/m ² K/m ²	DIN 53453 DIN 53453	12 12
Resistenza all'impatto ad intaglio IZOD <i>Notched impact strenght IZOD</i>	N/mm ² N/mm ²	ASTM D 256 ASTM D 256	100 100
Durezza <i>Hardness</i> H358/10 H358/60 Rockwell	N/mm ² N/mm ² N/mm ²	DIN 53456 DIN 53456 ASTM D 785	140 101 L102

Proprietà termiche <i>Thermal properties</i>	Unità <i>Unit</i>	Metodo per il test <i>Method test</i>	Valori <i>Value</i>
Coefficiente di ossigeno <i>Oxygen index</i>	% %	ASTM D 2863 ASTM D 2863	19 19
Ritardamento di fiamma (1/6 mm spessore) <i>Flame retardancy (1/6 mm trickness)</i>	- -	UL stand 94 UL stand 94	94HB 94HB
Resistenza al calore: Vicat, Metodo B <i>Heat resistance: Vicat, Method B</i>	°C °C	ASTM D 1525 ASTM D 1525	210-215 210-215
Conduttività termica <i>Thermal conductivity</i>	W/m ² C W/m ² C	ASTM C 177 ASTM C 177	0,19 0,19
Flusso di contrazione dello stampo <i>Modul shrinkage flow</i>	% %	ASTM D 1299 ASTM D 1299	0,4-0,6 0,4-0,6
Direzione di flusso trasversale <i>Cross flow direction</i>	% %	ASTM D 1299 ASTM D 1299	0,6-0,8 0,6-0,8

Proprietà fisiche <i>Physicals properties</i>	Unità <i>Unit</i>	Metodo per il test <i>Method test</i>	Valori <i>Value</i>
Assorbimento dell'acqua <i>Water absorption</i> 24 ore, 23°C 24 Hrs, 23°C	%	ASTM D 570	0,06

Resistenza chimica del PBT
Chemical resistance of PBT

Acidi <i>Acids</i>	°C	% giorni immulsione <i>% Immulsion days</i>	% Forza di ritenzione <i>% Strenght of ritenion</i>
10% Cloridrico <i>10% Hydrochloric</i>	23	30	89
	23	90	85
	23	180	82
10% Solforico <i>10% Sulfuric</i>	23	30	97
	23	90	94
	23	180	90
36% Solforico (batteria) <i>36% Sulfuric (battery)</i>	23	30	89
	23	30	97
	23	180	96
	66	30	84
10% Acetico <i>10% Acetic</i>	66	180	35
	23	30	89
	23	180	88

Basi <i>Bases</i>	°C	% giorni immulsione <i>% Immulsion days</i>	% Forza di ritenzione <i>% Strenght of ritenion</i>
5% Idrossido di potassio <i>5% Potassium Hydroxide</i>	23	30	83
	23	90	10
10% Idrossido di sodio <i>10% Sodium Hydroxide</i>	23	30	2
	23	180	-
10% Idrossido di Ammonio <i>10% Ammonium Hydroxide</i>	23	30	90
	23	90	87
	23	180	58

Solventi organici <i>Organic Solvents</i>	°C	% giorni immulsione <i>% Immulsion days</i>	% Forza di ritenzione <i>% Strenght of ritenion</i>
Alcol etilico <i>Ethyl Alcohol</i>	23	30	99
	23	180	94
Alcol metilico <i>Methyl Alcohol</i>	23	30	91
	23	180	76
Alcol isopropilico <i>Isopropyl-Alcohol</i>	23	30	100
	23	180	100
Alcol isopropilico e acqua (50:50) <i>Isopropyl-Alcohol & Water (50:50)</i>	23	30	93
	23	180	96
Acquaragia <i>Turpentine</i>	23	180	92
	23	30	66
Acetone <i>Acetonz</i>	23	180	63
	23	30	90



Tabella - Diametri foro del cuscinetto
 Table - Hole bearing diameters

Dimensioni Dimensions	Tipologia supporto Support type		Cuscinetto Bearing	Carico assiale dinamico (kN) Axial dynamic load (kN)	Carico radiale dinamico (kN) Radial dynamil load (kN)
Ø 6	ad incastro fixed	FK 6	706 DFA	-	-
		EK 6			
	ad appoggio supported	EF 6	606 ZZ	-	2,31
		EF 8			
Ø 8	ad incastro fixed	FK 8	708 DFA	-	-
		EK 8			
	ad appoggio supported	FF 10	608 ZZ	-	3,35
		BF 10			
Ø 10	ad incastro fixed	FK 10	7000 DFA	6,7	2,78
		BK 10			
	ad appoggio supported	FF 12	6000 ZZ	-	4,65
		BF 12			
Ø 12	ad incastro fixed	FK 12	7001 DFA	7,25	3,1
		BK 12			
	ad appoggio supported	-	-	-	-
Ø 15	ad incastro fixed	FK 15	7003 DFA	7,75	4,07
		BK 15			
	ad appoggio supported	FF 15	6002 ZZ	-	5,7
		BF 15			
Ø 17	ad incastro fixed	BK 17	7206 DFA	14	5,95
		BF 17	6203 ZZ	-	9,75
Ø 20	ad incastro fixed	FK 20	7204 DFA	18,3	9,7
		BK 20			
	ad appoggio supported	FF 20	6204 ZZ	-	13
		BF 20	6004 ZZ	-	9,55
Ø 25	ad incastro fixed	FK 25	7205 DFA	20,6	11,7
		BK 25			
	ad appoggio supported	FF 25	6205 ZZ	-	14,3
		BF 25			
Ø 30	ad incastro fixed	FK 30	7206 DFA	28,6	16,6
		BK 30			
	ad appoggio supported	FF 30	6206 ZZ	-	19,8
		BF 30			
Ø 35	ad incastro fixed	BK 35	7207 DFA	-	-
		BF 35	6207 ZZ	-	25,5
Ø 40	ad incastro fixed	BK 40	7208 DFA	45	27,7
		BF 40	6208 ZZ	-	29,7

NOTA:
 I supporti a incastro EK montano gli stessi cuscinetti dei supporti FK della medesima dimensione.
 I supporti ad appoggio EF montano gli stessi cuscinetti dei supporti ad appoggio FF della medesima dimensione.

NOTE:
 In the fixed supports EK there are the same bearings of the same size of fixed supports FK.
 In the floated supports EF there are the same bearings of the same size of floated supports FF.

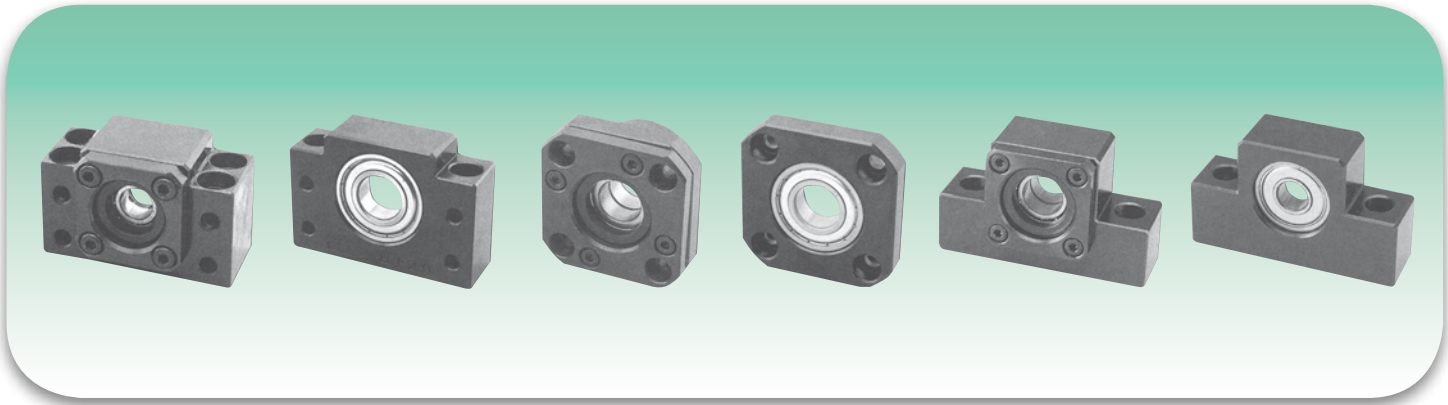
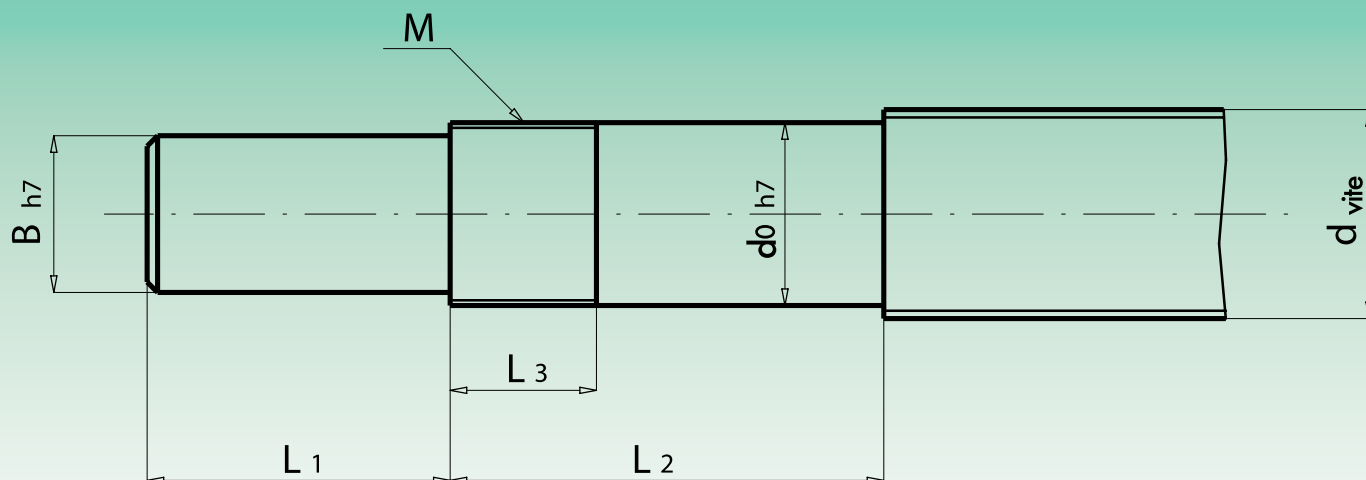

Per supporti di tipologia ad incastro FK, BK e EK.
For fixed-side support unit types FK, BK and EK.

Codoli raccomandati - Recommended shaft and shape

Tipo Type	Dimensioni - Dimensions						
	d ₀	d _{vite}	B	L ₁	L ₂	M	L ₃
mm							
FK 5	5	6	4	6	20	M 5x0.75	7
FK 6	6	8	4	8	24	M 6x0.75	8
FK 8	8	10	6	10	32	M 8x1	10
FK 10	10	12/14	8	15	39	M 10x1	12
FK 12	12	14/16	10	15	39	M 12x1	12
FK 15	15	20	12	20	41	M 15x1	12
FK 20	20	25/32	17	27	59	M 20x1	14
FK 25	25	32	20	36	68	M 25x1.5	18
FK 30	30	40	25	42	72	M 30x1.5	24
BK 10	10	12/14	8	15	39	M 10x1	12
BK 12	12	14/16	10	15	39	M 12x1	12
BK 15	15	20	12	20	41	M 15x1	12
BK 17	17	20/25	15	27	53	M 17x1	14
BK 20	20	25/32	17	27	53	M 20x1	14
BK 25	25	32	20	36	65	M 25x1.5	18
BK 30	30	40	25	42	72	M 30x1.5	24
BK 35	35	40	30	58	83	M 35x1.5	28
BK 40	40	50	35	70	98	M 40x1.5	35
EK 5	5	6	4	6	20	M 5x0.75	7
EK 6	6	8	4	8	24	M 6x0.75	8
EK 8	8	10	6	10	32	M 8x1	10
EK 10	10	12/14	8	15	39	M 10x1	12
EK 12	12	14/16	10	15	39	M 12x1	12
EK 15	15	20	12	20	41	M 15x1	12
EK 20	20	25/32	17	27	59	M 20x1	14

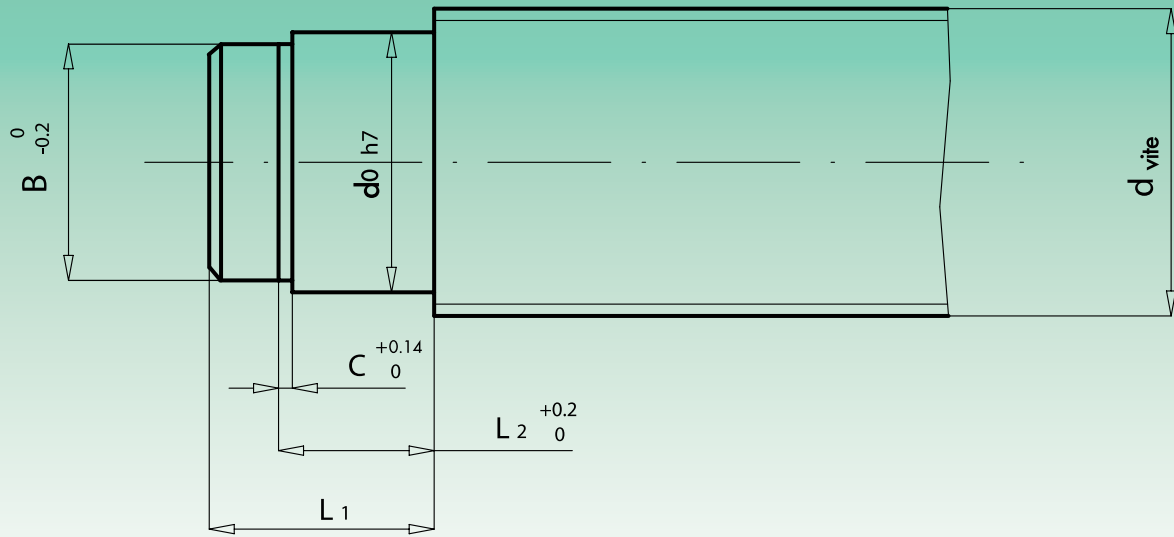

Per supporti di tipologia ad appoggio FF, BF e EF.
For floated-side support unit types FF, BF and EF.

Codoli raccomandati - Recommended shaft and shape

Tipo Type	Dimensioni - Dimensions					
	d_0	d_{vite}	B	C	L_1	L_2
mm						
FF 10	8	10/12	7,6	0,9	11	7,9
FF 12	10	16	9,6	1,15	12	9,15
FF 15	15	20	14,3	1,15	12	10,15
FF 20	20	25/32	19	1,35	18	15,35
FF 25	25	32	23,9	1,35	20	16,35
FF 30	30	40	28,6	1,75	20	17,75
BF 10	8	10/12	7,6	0,9	11	7,9
BF 12	10	16	9,6	1,15	12	9,15
BF 15	15	20	14,3	1,15	12	10,15
BF 17	17	20/25	16,2	1,15	16	13,15
BF 20	20	25/32	19	1,35	16	13,35
BF 25	25	32	23,9	1,35	20	16,35
BF 30	30	40	28,6	1,75	20	17,75
BF 35	35	40	33	1,75	25	19,75
BF 40	40	50	38	1,75	25	19,75
EF 6	6	8	5,6	0,8	9	7,0
EF 8	6	8	5,6	0,9	10	7,0
EF 10	8	10/12	7,6	0,9	11	7,9
EF 12	10	16	9,6	1,15	12	9,15
EF 15	15	20	14,3	1,15	12	10,15
EF 20	20	25/32	19	1,35	18	15,35

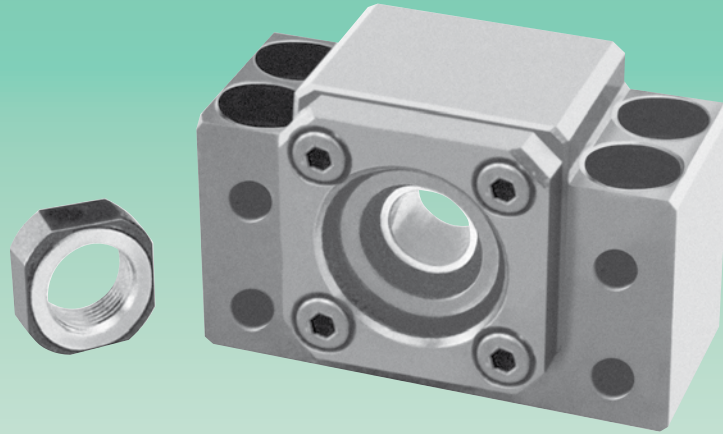
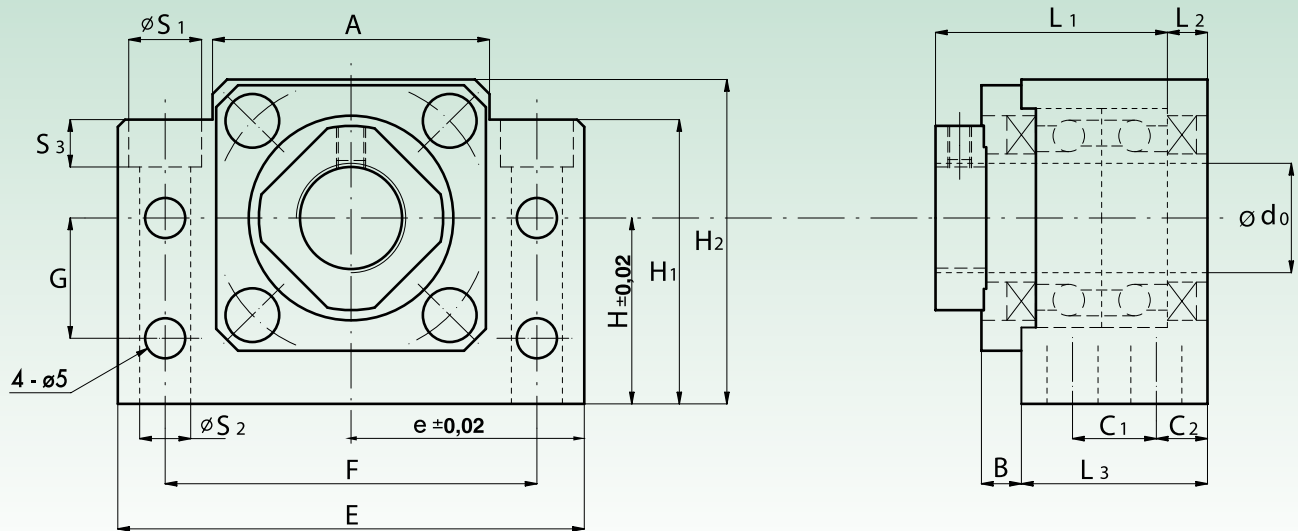
Supporti di tipologia ad incastro BK, FK e EK
Fixed-side support unit types BK, FK and EK

Ghiera inclusa
Lock nut included

Tipo Type	Dimensioni - Dimensions																			
	d_0	L_1	L_2	L_3	$H \pm 0,02$	H_1	H_2	A	B	C_1	C_2	E	$e \pm 0,02$	F	G	s	S_1	S_2	S_3	
mm																				
BK 10	10	31	7	25	22	32,5	39	34	6	13	6	60	30	46	15	5,5	11	6,6	5	
BK 12	12	31	7	25	25	35	43	35	6	13	6	60	30	46	18	5,5	11	6,6	6,5	
BK 15	15	33	7	27	28	38	48	40	6	15	6	70	35	54	18	5,5	11	6,6	6,5	
BK 17	17	43	9	35	39	55	64	50	8	19	8	86	43	68	28	6,6	14	9	8,5	
BK 20	20	43	9	35	34	50	60	52	8	19	8	88	44	70	22	6,6	14	9	8,5	
BK 25	25	52	10	42	48	70	80	64	12	22	10	106	53	85	33	9	17,5	11	11	
BK 30	30	55	11	45	51	78	89	76	14	23	11	128	64	102	33	11	20	14	13	
BK 35	35	63	12	50	52	79	96	88	14	26	12	140	70	114	35	11	20	14	13	
BK 40	40	71	16	61	60	90	110	100	18	33	14	160	80	130	37	14	26	18	17,5	

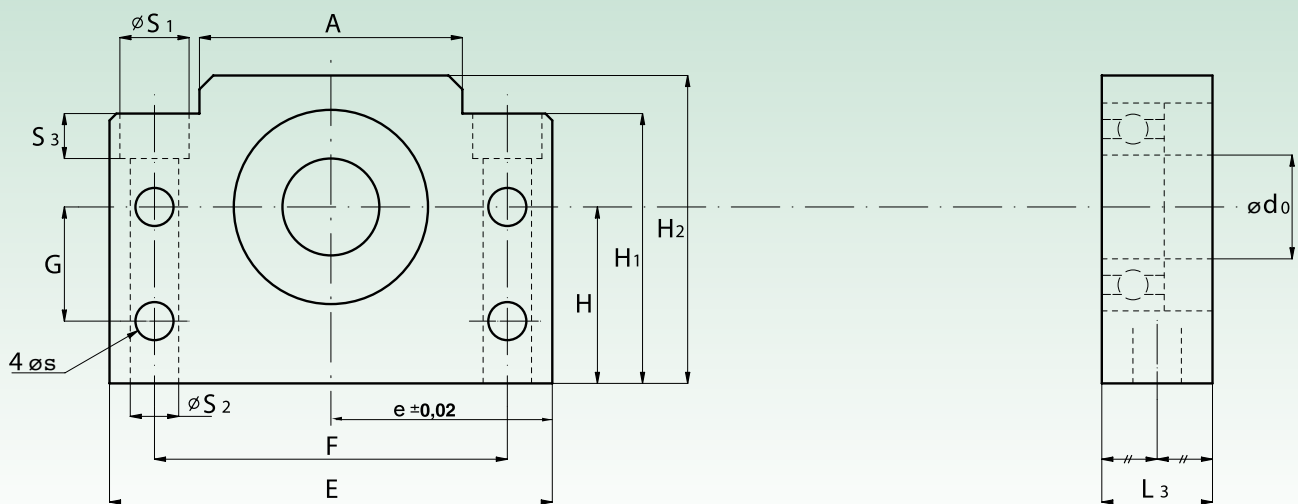
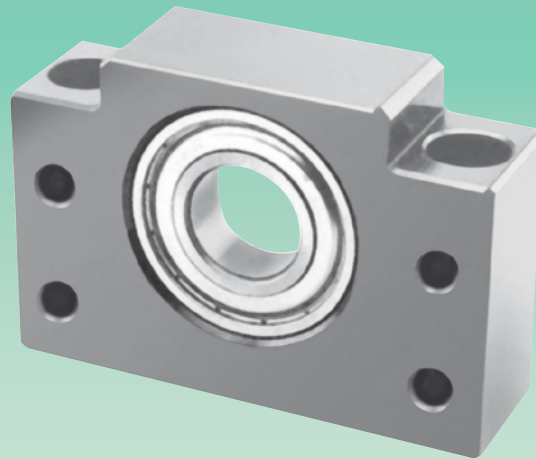
Supporti di tipologia ad appoggio BF, FF e EF
Floated-side support unit types BF, FF and EF

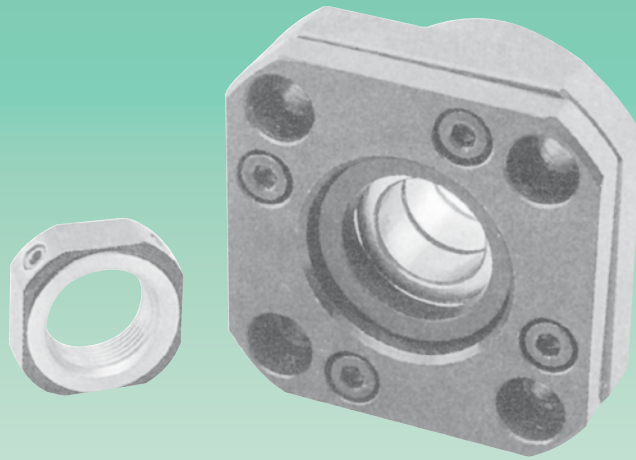
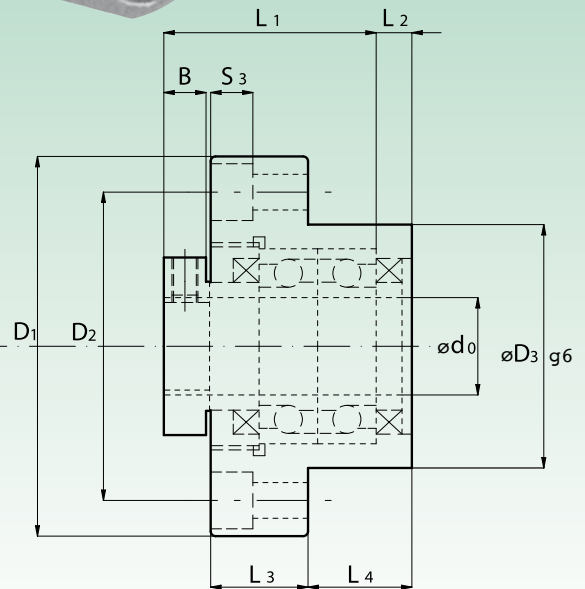
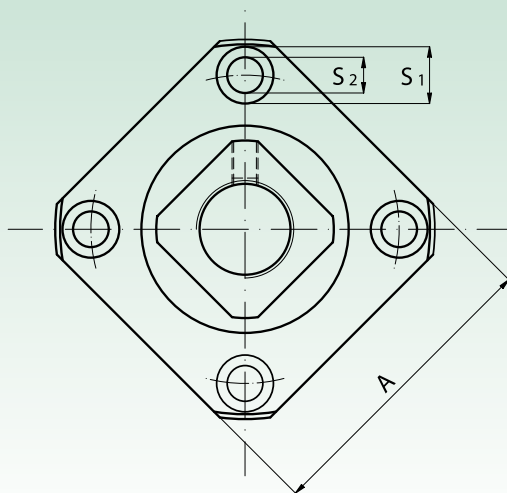

Tipo Type	Dimensioni - Dimensions													
	d_0	L_3	$H^{\pm 0,02}$	H_1	H_2	A	E	$e^{\pm 0,02}$	F	G	s	S_1	S_2	S_3
mm														
BF 10	8	20	22	32,5	39	34	60	30	46	15	5,5	11	6,6	5
BF 12	10	20	25	35	43	35	60	30	46	18	5,5	11	6,6	6,5
BF 15	15	20	28	38	48	40	70	35	54	18	5,5	11	6,6	6,5
BF 17	17	23	39	55	64	50	86	43	68	28	6,6	14	9	8,5
BF 20	20	26	34	50	60	52	88	44	70	22	6,6	14	9	8,5
BF 25	25	30	48	70	80	64	106	53	85	33	9	17,5	11	11
BF 30	30	32	51	78	89	76	128	64	102	33	11	20	14	13
BF 35	35	32	52	79	96	88	140	70	114	35	11	20	14	13
BF 40	40	37	60	90	110	100	160	80	130	37	14	26	18	17,5

Supporti di tipologia ad incastro FK, BK e EK
Fixed-side support unit types FK, BK and EK

Ghiera inclusa
Lock nut included

Tipo Type	Dimensioni - Dimensions												
	d ₀	D ₁	D ₂	D ₃	L ₁	L ₂	L ₃	L ₄	A	B	S ₁	S ₂	S ₃
mm													
FK 5	5	34	26	20	18,5	3,5	6	10,5	26	5	6,5	3,4	4
FK 6	6	36	28	22	22	3,5	7	13	28	5	6,5	3,4	4
FK 8	8	43	35	26	26	4	9	14	35	6,5	6,5	3,4	4
FK 10	10	52	42	34	29	5	11	17	42	8	8	4,5	5
FK 12	12	54	44	36	29,5	5	11	17	44	8	8	4,5	5
FK 15	15	63	50	40	33	6	15	17	52	8	9,5	5,5	6
FK 20	20	85	70	57	48	10	22	30	68	10	11	6,6	10
FK 25	25	98	80	63	57	10	27	30	79	10	14	9	11
FK 30	30	117	95	75	60	11	30	32	93	12	17,5	11	13

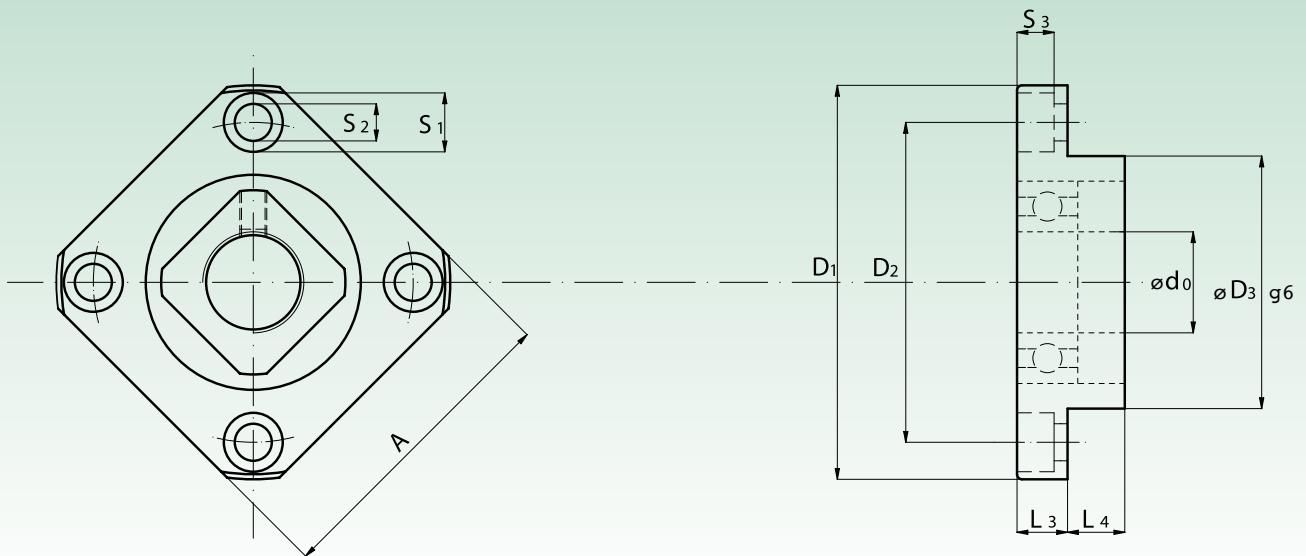
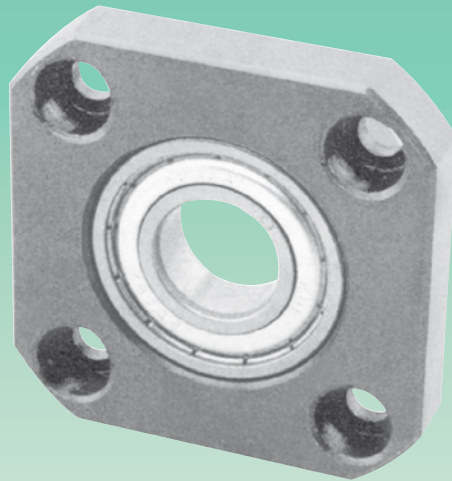
Supporti di tipologia ad appoggio FF, BF e EF
Floated-side support unit types FF, BF and EF

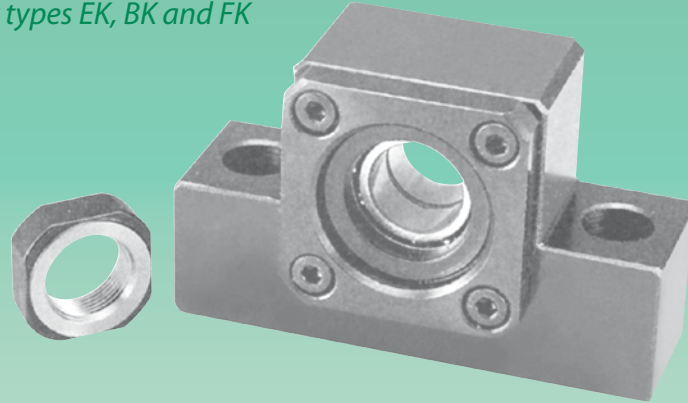
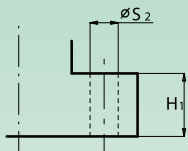
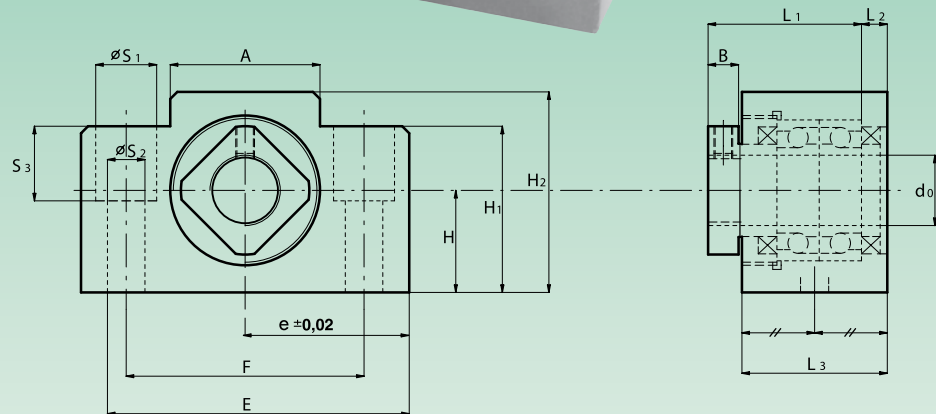
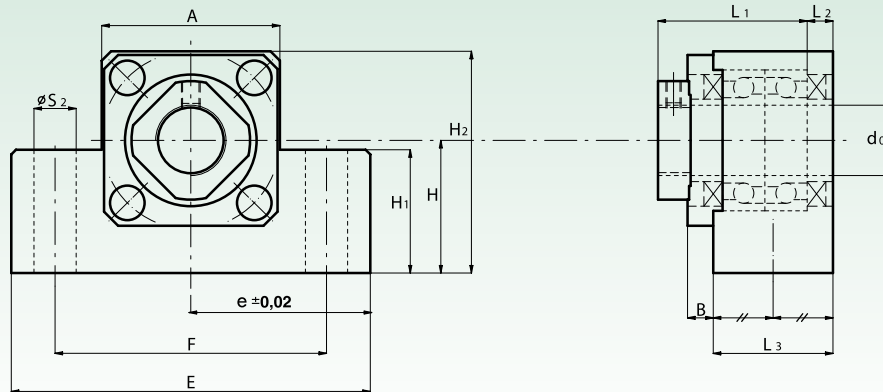

Tipo Type	Dimensioni - Dimensions									
	d ₀	D ₁	D ₂	D ₃	L ₃	L ₄	A	S ₁	S ₂	S ₃
	mm									
FF 10	8	43	35	28	7	5	35	6,5	3,4	4
FF 12	10	52	42	34	7	8	42	8	4,5	4
FF 15	15	63	50	40	9	8	52	9,5	5,5	6
FF 20	20	85	70	57	11	9	68	11	6,6	6,5
FF 25	25	98	80	63	14	10	79	14	9	9
FF 30	30	117	95	75	18	17	93	17,5	11	11

Supporti di tipologia ad incastro EK, BK e FK
Fixed-side support unit types EK, BK and FK

Ghiera inclusa
Lock nut included

EK 5

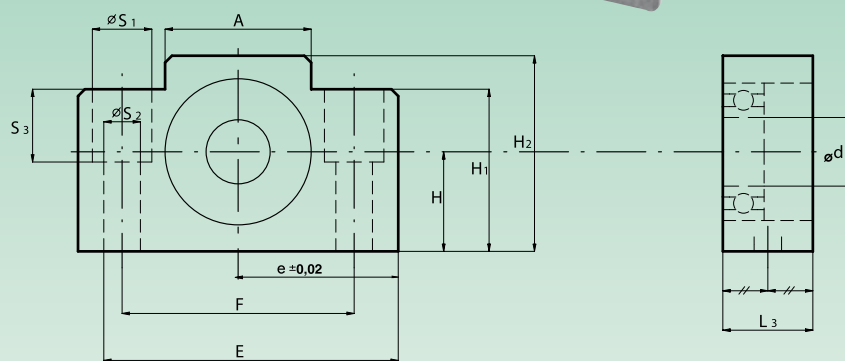
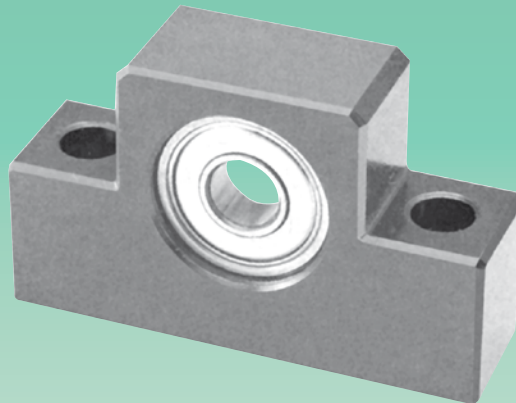
EK 6-8

EK 10 - 20

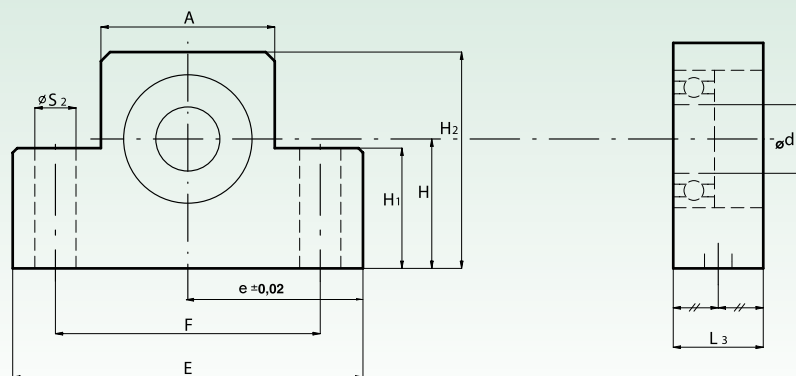
Tipo Type	Dimensioni - Dimensions														
	d_0	L_1	L_2	L_3	$H^{\pm 0,02}$	H_1	H_2	A	B	E	$e^{\pm 0,02}$	F	S_1	S_2	S_3
mm															
EK 5	5	18,5	3,5	16,5	11	8	21	20	5	36	18	28	-	4,5	-
EK 6	6	22	3,5	20	13	20	25	18	5	42	21	30	9,5	5,5	11
EK 8	8	26	4	23	17	26	32	25	6,5	52	26	38	11	6,6	12
EK 10	10	29	7	24	25	24	43	36	6	70	35	52	-	9	-
EK 12	12	29,5	7	24	25	24	43	36	6	70	35	52	-	9	-
EK 15	15	33	7	25	30	25	49	41	6	80	40	60	-	11	-
EK 20	20	48	10	42	30	25	58	56	10	95	47,5	75	-	11	-

Supporti di tipologia ad appoggio EF, BF e FF
Floated-side support unit types EF, BF and FF



EF 6-8



EF 10-20

Tipo Type	Dimensioni - Dimensions											
	d ₀	L ₃	H _{±0,02}	H ₁	H ₂	A	E	e _{±0,02}	F	S ₁	S ₂	S ₃
mm												
EF 6	6	12	13	20	25	18	42	21	30	9,5	5,5	11
EF 8	6	14	17	26	32	25	52	26	38	11	6,6	12
EF 10	8	20	25	24	43	36	70	35	52	-	9	-
EF 12	10	20	25	24	43	36	70	35	52	-	9	-
EF 15	15	20	30	25	49	41	80	40	60	-	9	-
EF 20	20	26	30	25	58	56	95	47,5	75	-	11	-

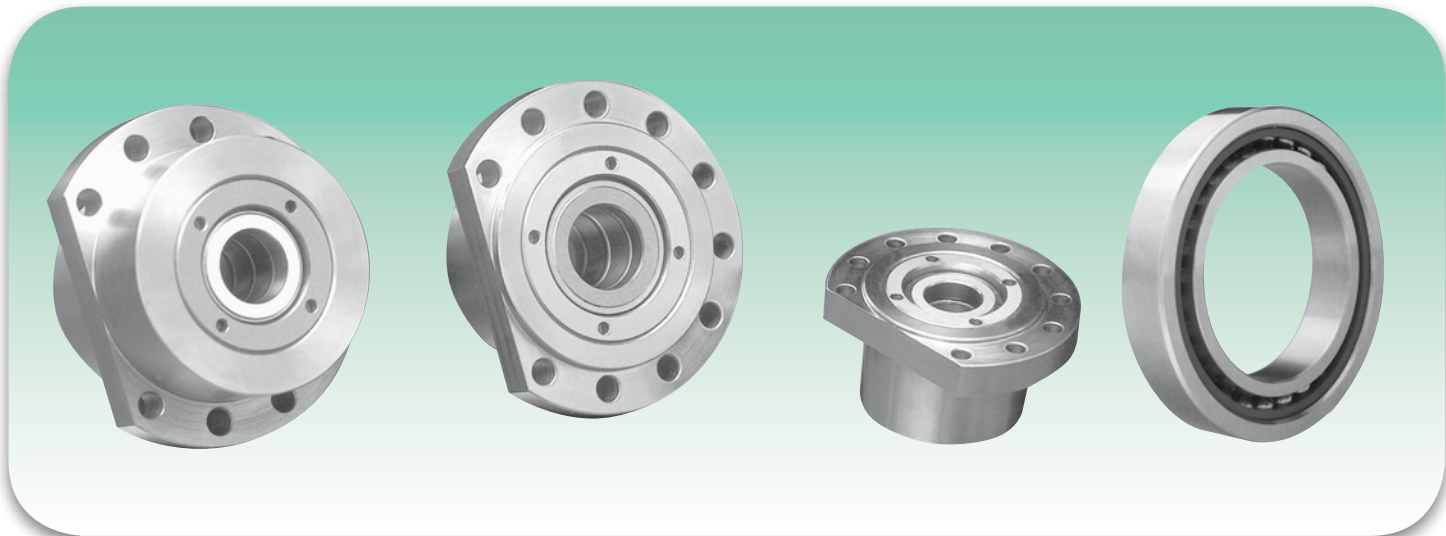
CARATTERISTICHE TECNICHE
TECHNICAL CHARACTERISTICS

- **Materiale**
Supporto: Acciaio C40 rettificato.
- **Cuscinetti:** ISB assiali a contatto obliquo della serie dimensionale ISO 02 (codice equivalente: FAG 76020) angolo di contatto 60°.
- **Classe di precisione:** Tolleranze ridotte nella classe di precisione ISO P4 corrispondente alla classe ISO P4S.
- **Pre-carico:** I cuscinetti sono prodotti in esecuzione universale. I valori di pre-carico sono indicati nella seguente tabella e corrispondono a valori di pre-carico elevati. Possono essere forniti coppie e quaterne con valori di pre-carico a richiesta.
- **Material**
Bearing unit: C40 rectified steel.
- **Bearings:** Angular contact thrust ball bearings ISB of dimensional series ISO 02 (equivalent code: FAG 76020). Contact angle 60°.
- **Precision class:** Reduced tolerances in ISO P4 precision class, corresponding to ISO P4S.
- **Pre-load:** Bearings are produced in universal execution. Preload values are indicated in the following table and correspond to high preload values. Couples and quaternary groups of pre-load values can be provided by specific request.

Supporti con cuscinetti di precisione assiali a contatto obliquo
Supports with precision axial angular contact bearings

• **Forza di serraggio:**

In presenza di una forza di serraggio eccessiva, gli anelli dei cuscinetti subiscono una deformazione elastica che provoca un aumento della forza di precarico ed una diminuzione della durata. Il valore della forza di serraggio può essere calcolata, con l'ausilio della tabella sotto riportata.

• **Tolleranze:** Le tolleranze di lavorazione e le dimensioni di montaggio sono indicate nelle tabelle a seguire:

• **Clamping force:**

In case of very strong clamping force, bearings rings are affected by an elastic deformation that causes an increase of the pre-load force together with a shortening of the duration. The value of the clamping force can be calculated by means of the table below.

• **Tolerances:** The following table reports the working tolerances and the mounting dimensions:

FORZE DI SERRAGGIO F ₂ CONSIGLIATE - RECOMMENDED F ₂ CLAMPING FORCES							
Disposizione cuscinetto <i>Position of the bearing</i>							
Fz [N]	3 - Fv		4 - Fv		6 - Fv		
Filettatura Thread	M5	M6	M8	M10	M12	M14	M16
Fattore F Factor F	0,98	1,18	1,55	1,9	2,35	2,7	30,5

La forza di serraggio F₂ viene raggiunta quando le viti del coperchio vengono serrate con la coppia M.

$$M = Fz/f[Nmm]$$

N = Numero di viti del coperchio

f. = Fattore di correzione

Clamping force F₂ is achieved when the cover's ball screws are clamped with the M couple.

$$M = Fz/f (Nmm)$$

N = number of cover's ball screws

f. = Correction factor

TOLLERANZE DI LAVORAZIONE DEGLI ALBERI E DELLE PARTI ADIACENTI

WORKING TOLERANCES OF SHAFT AND ADJACENT PARTS

VALORI INDICATIVI PER LA LAVORAZIONE DEGLI ALBERI VALUES FOR PROCESSING SHAFTS						
Dimensione nominale dell'albero (d) <i>Shaft's nominal dimension (d)</i>	Dimensioni - Dimensions					
	mm					
	Oltre / Over	10	18	30	50	
fino a / up to	10	18	30	50	80	
CUSCINETTI ASSIALI A SFERE A CONTATTO OBLIQUO A SEMPLICE EFFETTO SIMPLE EFFECT ANGULAR CONTACT AXIAL BALL BEARINGS						
Scostamento (d) <i>(d) deviation</i>		-9	-11	-13	-15	
Precisione di forma cilindrica <i>Cylindrical form precision</i>	t1	2,5	2,5	3	4	
Precisione assiale di rotazione <i>Axial rotation precision</i>	t3	2,5	2,5	3	4	
Valore medio di rugosità <i>Roughness mean value</i>	Ra	0,4	0,4	0,4	0,4	

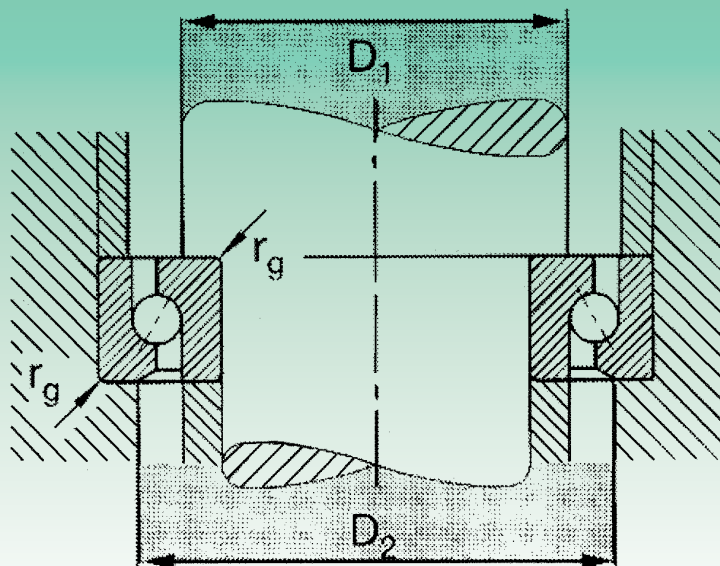
DIMENSIONI DI MONTAGGIO PER CUSCINETTI ASSIALI A SFERE A CONTATTO OBLIQUO
MOUNTING DIMENSIONS FOR ANGULAR CONTACT AXIAL BALL BEARINGS

Albero Shaft	Cuscinetto tipo ISB 204714 AC (equivalente Fag 76020) 204714 AC ISB type bearing (Fag 76020 equivalent)		
Fore Bore	D1	D2	rg
mm	min	min	max
12	17	27	0,6
15	20,5	30	0,6
17	23	34,5	0,6
20	27,5	39,5	0,6
25	32	45	1
30	39,5	52,5	1
35	46,5	60,5	1
40	53,5	69,5	1
45	57	73	1
50	63	79	1

- Tenute:** I segmenti lamellari fey a 3 anelli espansori singoli, tipo FK3 AS, costruiti in acciaio per molle C75, creano una classica tenuta a labirinto.
- Lubrificazione:** Grassi al sapone di litio, con additivi EP come ad esempio il grasso ARCANOL L 135V, consistenza 2, °C – 40 + 150. I supporti sono già forniti lubrificati, con la quantità indicata nella tabella seguente.
- Seals:** Spathic segments fey with three expander rings, FK3 AS type, made of steel for stainless steel C75 springs, create a typical labyrinth seal.
- Lubrication:** Lithium soap greases with EP additives like ARCANOL L 135V grease, consistency 2, °C-40 + 150. Bearing units are supplied when already lubrified in the quantity indicated in the next table.

Supporti con cuscinetti di precisione assiali a contatto obliquo

Supports with precision axial angular contact bearings

Quantitativi di grasso per cuscinetti assiali a sfere a contatto obliquo, ad una corona.
Quantities of grease for angular contact axial ball bearings, single row.

Sigla Fag Type Fag	7602020TVP	7602025TVP	7602030TVP	7602035TVP
grasso g. / grease g.	1,42	1,95	2,65	3,7
Sigla Fag Type Fag	7602040TVP	7602045TVP	7602050TVP	
grasso g. / grease g.	4,45	5,35	6,5	

- **Accessori:** Ghiere di precisione rettificata con fissaggio a grani, serie ZM.

- **Tools:** Precision ground lock-nuts with dowel fixing, ZM series.

ESECUZIONI UNITÀ CARTUCCIA FLANGIATA
UNITY EXECUTIONS - FLANGED CARTRIDGE

Tipo Type	Descrizione Specification
ISB FD	FLANGIATA CON 2 CUSCINETTI A 'O' FLANGED WITH 2 'O' BEARINGS
ISB FQ	FLANGIATA CON 4 CUSCINETTI A 'O' FLANGED WITH 4 'O' BEARINGS
ISB FDX	FLANGIATA CON 2 CUSCINETTI A 'X' FLANGED WITH 2 'X' BEARINGS
ISB FQX	FLANGIATA CON 4 CUSCINETTI A 'X' FLANGED WITH 4 'X' BEARINGS

TABELLA DI CORRISPONDENZA
EQUIVALENT TABLE

Tipo ISB ISB Type	SNFA	FAFNIR	RHP
ISB FD	BSDU DD	BSBU D	BSCU D
ISB FQ	BSQU TDT	BSBU Q	BSCU Q
ISB FDX	BSDU FF	-	-
ISB FQX	BSQU TFT	-	-

CODICE DI IDENTIFICAZIONE
SPECIFICATION CODE

ISB	F	D	X	030	precarico da N pre-load from N	
MARCA BRAND	ESECUZIONE FLANGIATA FLANGED EXECUTION	D=2 CUSCINETTI Q=4 CUSCINETTI D=2 BEARINGS Q=4 BEARINGS	Nessun codice	FORO CUSCINETTO BEARING BORE	Nessun numero: esecuzione	Without number: execution
			No	020 = 20 MM	precarico.	pre-load.
			codice	025 = 25 MM	universale	universal
			esecuzione a	030 = 30 MM	Con numero:	With number:
			'O'	035 = 35 MM	precarico	pre-load
			X per	040 = 40 MM	Speciale X	Special X
			esecuzione a	045 = 45 MM	360=360 da N	360=360 from N
			'X'	050 = 50 MM		

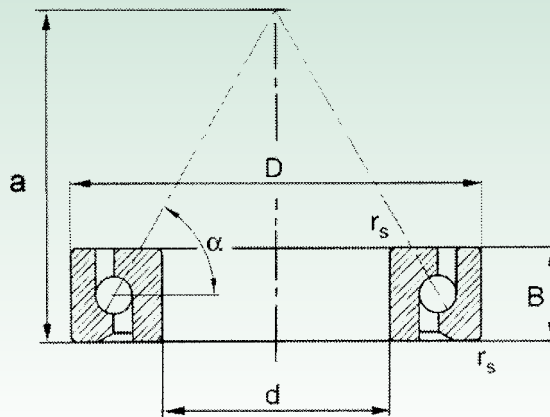

204714 AC

 Angolo di contatto $\alpha \approx 60^\circ$ - Contact Angle $\alpha \approx 60^\circ$

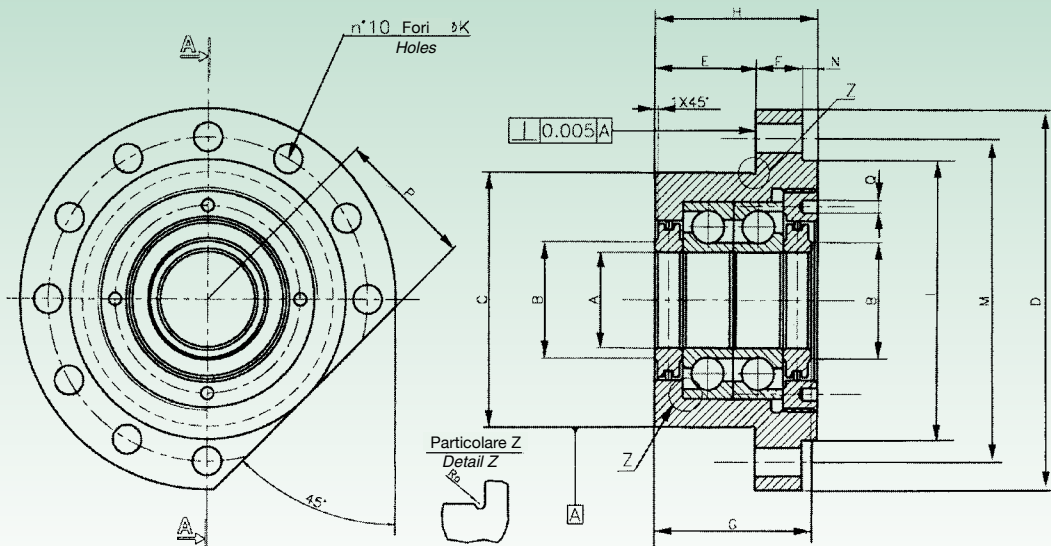
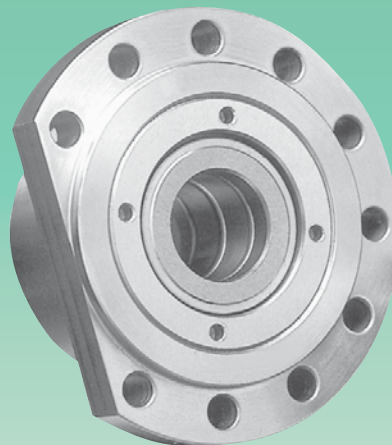
Cuscinetti ISB Bearings	Equivalente FAG Equivalent	Dimensioni - Dimensions					Capacità di carico Load ability		Carico assiale Axial load max	Velocità rotazione raggiungibile Achievable rotation speed		Forza di pre-carico Pre-load force	Momento d'attrito Friction point	Peso Weight
							din.	Stat.		Grasso Grease	Olio Oil			
Tipo Type	Tipo Type	d	D	B	r _{smin}	a ≈	C	Co	din	Velocità - Speed		F _v	Mr	Kg
mm						KN						kN	Nmm	
174012AC	7602017TVP	17	40	12	0,6	31	16,6	20	8,5	6000	8000	1,7	30	0,075
204714AC	7602020TVP	20	47	14	1	6	19,3	25	10,6	5000	6700	2,3	50	0,130
255215AC	7602025TVP	25	52	15	1	41	22	30,5	13,2	4500	6000	2,5	65	0,160
306216AC	7602030TVP	30	62	16	1	48	26	39	17	3800	5000	2,9	85	0,240
357217AC	7602035TVP	35	72	17	1,1	55	30	50	21,2	3200	4300	3,3	115	0,345
408018AC	7602040TVP	40	80	18	1,1	62,5	37,5	64	28	2800	3800	4,3	170	0,445
458519AC	7602045TVP	45	85	19	1,1	66	38	68	28	2800	3600	4,5	190	0,505
509020AC	7602050TVP	50	90	20	1,1	71,5	39	75	31,5	2400	3400	4,9	230	0,575

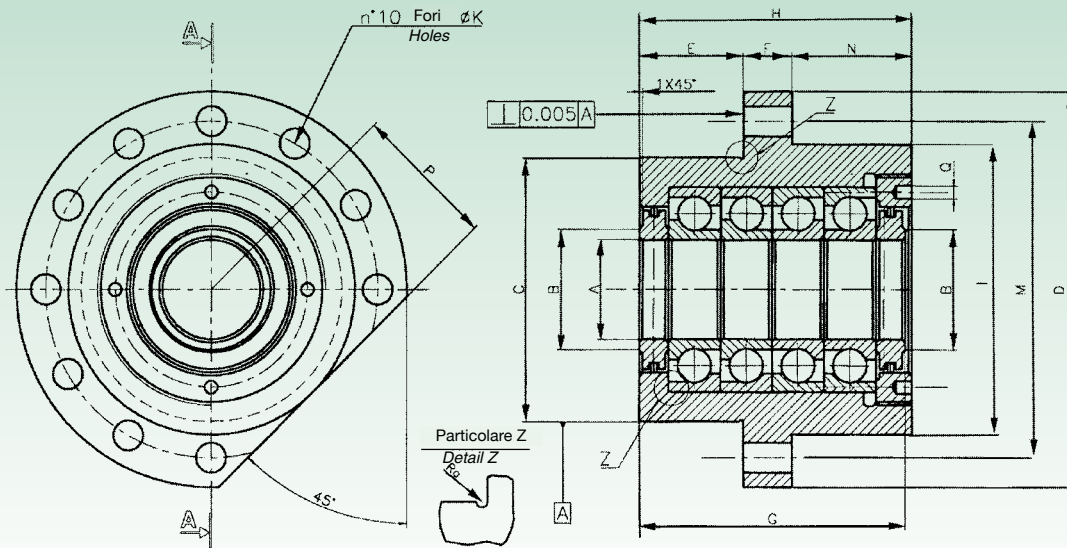

ALBERO Ø mm. SHAFT Ø mm.	Tipo Type	SUPPORTI ISB TIPO FD PER CUSCINETTI - DIMENSIONI SENZA TOLLERANZA: ± 0.13 mm. ISB UNITS TYPE FD, FOR BEARINGS - DIMENSIONS WITHOUT TOLERANCE: ± 0.13 mm.														
		A	B	C	D	E	F	G	H	I	K	M	N	P	Q	Rc
17	ISB FD 017 (17-40-12)	17 16.996	25	60 59.987	90	32	13	44.260 43.240	47	64	6,6	76	2	32	4,3	0,5
20	ISB FD 020 (20-47-14)	20 19.669	28	60 59.987	90	32	13	44.260 43.240	47	64	6,6	76	2	32	4,3	0,5
25	ISB FD 025 (25-52-12)	25 24.996	35	80 79.987	120	32	15	50.260 49.240	52	88	9,2	102	5	44	4,3	0,5
30	ISB FD 030 (30-62-12)	30 29.996	41	80 79.987	120	32	15	50.260 49.240	52	88	9,2	102	5	44	4,3	0,5
35	ISB FD 035 (35-72-17)	35 34.995	46	90 89.987	130	32	15	50.260 49.240	52	98	9,2	113	5	49	4,3	0,5
40	ISB FD 040 (40-80-18)	40 39.995	55	124 123.982	165	43,5	17	64.260 63.240	66	128	11,4	146	5,5	32	5,3	0,5
45	ISB FD 045 (45-85-19)	45 44.995	66	124 123.982	165	43,5	17	64.260 63.240	66	128	11,4	146	5,5	44	5,3	0,5
50	ISB FD 050 (50-90-20)	50 49.995	66	124 123.982	165	43,5	17	64.260 63.240	66	128	11,4	146	5,5	44	5,3	0,5



ALBERO Ø mm. SHAFT Ø mm.	Tipo Type	SUPPORTI ISB TIPO FD PER CUSCINETTI - DIMENSIONI SENZA TOLLERANZA: ± 0.13 mm. ISB UNITS TYPE FD, FOR BEARINGS - DIMENSIONS WITHOUT TOLERANCE: ± 0.13 mm.														
		A	B	C	D	E	F	G	H	I	K	M	N	P	Q	Rc
17	ISB FQ 017 (17-40-12)	17 16.996	25	60 59.987	90	32	13	74.260 72.740	77	64	6,6	76	32	32	4,3	0,5
20	ISB FQ 020 (20-47-14)	20 19.669	28	60 59.987	90	32	13	74.260 72.740	77	64	6,6	76	32	32	4,3	0,5
25	ISB FQ 025 (25-52-15)	25 24.996	35	80 79.987	120	32	15	80.260 78.240	82	88	9,2	102	35	44	4,3	0,5
30	ISB FQ 030 (30-62-16)	30 29.996	41	80 79.987	120	32	15	80.260 78.740	83	88	9,2	102	36	44	4,3	0,5
35	ISB FQ 035 (35-72-17)	35 34.995	46	90 89.987	130	32	15	84.260 82.740	86	98	9,2	113	39	49	4,3	0,5
40	ISB FQ 040 (40-80-18)	40 39.995	55	124 123.982	165	43,5	17	104.260 102.740	106	128	11,4	146	45,5	64	5,3	0,5
45	ISB FQ 045 (45-85-19)	45 44.995	66	124 123.982	165	43,5	17	104.260 102.740	106	128	11,4	146	45,5	64	5,3	0,5
50	ISB FQ 050 (50-90-20)	50 49.995	66	124 123.982	165	43,5	17	104.260 102.740	106	128	11,4	146	45,5	64	5,3	0,5





ISB®



©Copyright 

È vietata la riproduzione anche parziale del contenuto di questo catalogo tecnico. Non si possono accettare responsabilità per eventuali errori od omissioni. Le misure, i disegni e le immagini non sono impegnativi. Marchio registrato Italia-EU.

The reproduction, even partial, of the contained concerning this technical catalogue, is forbidden. Liability for possible errors and/or omissions are not accepted. The measurements, drawings and images are not demanding.™ Registered in Italy-EU.



SUPPORTI AUTOALLINEANTI
SELF-ALIGNING BEARING UNITS

01.01.2018 ©Copyright 



Adicionamos movimento ao seu negócio!

Serviços

Colagens no local
Serviço 24H
Cálculos de transmissão Formação
Projectos
Recondicionamento
Portal B2B
Visita técnica

Sede

R. António Silva Marinho, 66
4100-063 Porto | Portugal
Tel +351 226 197 360
Fax +351 226 197 361
vendasporto@juncor.pt

Filial - Montijo Comércio e Indústria

(Arm. 13/15)
EN 5 Pau Queimado - Afonseiro
2870-500 Montijo | Portugal
Tel +351 212 306 030
Fax +351 212 306 031
vendaslisboa@juncor.pt



www.juncor.pt



clientes.juncor.pt



facebook/juncor



twitter.com/juncor_sa



youtube.com/juncoraccess



linkedin.com/company/juncor-sa



pinterest.pt/juncorsa



instagram.com/juncor_sa